

**ANALISA SIFAT KELISTRIKAN DAGING AYAM
TERHADAP PENAMBAHAN FORMALIN DENGAN
METODE DIELEKTRIK**

SKRIPSI

oleh :

OSA NORAISE

125090301111006



JURUSAN FISIKA

FAKULTAS MATEMATIKA DAN ILMU PENGETAHUAN ALAM

UNIVERSITAS BRAWIJAYA

MALANG

2016

**ANALISA SIFAT KELISTRIKAN DAGING AYAM
TERHADAP PENAMBAHAN FORMALIN DENGAN
METODE DIELEKTRIK**

SKRIPSI

Sebagai salah satu syarat untuk memperoleh gelar

Sarjana sains dalam bidang fisika

oleh :

OSA NORAISE

125090301111006



JURUSAN FISIKA

FAKULTAS MATEMATIKA DAN ILMU PENGETAHUAN ALAM

UNIVERSITAS BRAWIJAYA

MALANG

2016

i

LEMBAR PENGESAHAN SKRIPSI

**ANALISA SIFAT KELISTRIKAN DAGING AYAM
TERHADAP PENAMBAHAN FORMALIN DENGAN
METODE DIELEKTRIK**

oleh :

OSA NORAISE

125090301111006

Setelah dipertahankan di depan Majelis Penguji

pada tanggal

dinyatakan memenuhi syarat untuk memperoleh gelar

Sarjana sains dalam bidang fisika

Pembimbing I

Pembimbing II

Chomsin Sulistya Widodo,PhD

Achmad Hidayat ,M.Si

NIP. 196910201995121002

NIP 196812101994031017

Mengetahui,

Ketua Jurusan Fisika

MIPA Universitas Brawijaya

Sukir Maryanto,PhD.

NIP. 197106211998021001

LEMBAR PERNYATAAN

Nama : Osa Noraise

NIM : 125090301111006

Jurusan : Fisika

Penulis Skripsi berjudul : “ Analisa Sifat Kelistrikan Daging Ayam Terhadap Penambahan Formalin Dengan Metode Dielektrik.”

Dengan ini menyatakan bahwa :

1. Isi dari Skripsi yang saya buat adalah benar-benar karya sendiri dan tidak menjiplak karya orang lain, nama- nama yang termaktub diisi dan tertulis di daftar pustaka dalam Skripsi ini.
2. Apabila dikemudian hari ternyata Skripsi yang saya tulis terbukti hasil jiplakan, maka saya akan bersedia menanggung segala resiko yang akan saya terima.

Demikian pernyataan ini dibuat dengan segala kesadaran

Malang, 24 Juli 2016

Yang menyatakan,

(Osa Noraise)

NIM 125090301111006

ANALISA SIFAT KELISTRIKAN DAGING AYAM TERHADAP PENAMBAHAN FORMALIN DENGAN METODE DIELEKTRIK

ABSTRAK

Daging ayam merupakan salah satu bahan makanan berprotein tinggi. Daging ayam bukan hanya sumber protein yang sangat baik, tetapi juga merupakan sumber vitamin dan mineral. Setiap bahan memiliki sifat listrik yang berbeda dan besarnya sangat ditentukan oleh kondisi internal bahan tersebut. Penelitian ini dilakukan untuk mengetahui karakteristik kelistrikan pada daging ayam yang diberi formalin dengan menggunakan metode dielektrik frekuensi rendah, untuk mengetahui nilai kapasitansi dan konstanta dielektrik pada daging ayam yang direndam pada formalin 0 mL, 10 mL, 20 mL, 30 mL, 40 mL dan 50 mL, direndam pada formalin selama 1 jam pada daging bermassa 3 gram. Karakteristik kelistrikan yang diukur yaitu kapasitansi dan konstanta dielektrik. Kapasitansi diukur dengan menggunakan plat kapasitor yang terbuat dari plat tembaga dengan ukuran 20 x 10 mm dengan jarak antar plat 5 mm. Pada bagian tengah plat di letakkan daging ayam dan dihubungkan pada LCR meter GW-instek seri 816 dengan probe ganda L dan H, sedangkan konstanta dielektrik diperoleh dari perhitungan nilai kapasitansinya. Pengukuran kapasitansi dilakukan dengan range frekuensi 100 Hz – 2000 Hz dengan interval 25 Hz. Hasil penelitian menunjukkan bahwa nilai kapasitansi mengalami penurunan untuk daging yang direndam pada formalin 0 ml sampai 30 ml dan mengalami kenaikan untuk daging yang direndam pada formalin 30 ml sampai 50 ml. Nilai kapasitansi berbanding lurus dengan nilai konstanta dielektrik. Nilai kapasitansi menurun seiring dengan besar frekuensi yang diberikan.

Kata kunci : Daging ayam, Formalin, Kapasitansi, Konstanta dielektrik.



ANALYSIS CHARACTERISTIC ELECTRICITY OF CHIKEN MEAT TO ADDITION FORMALINE WITH DIELECTRIC METHOD

ABSTRACT

Chicken meat is one of the highest protein food ingredients. The chicken meat is not only an excellent source of protein, but also a source of vitamins and minerals. Each material has unique electrical properties and the amount is determined by the internal state of the material. The study is conducted to determine the electrical characteristics in chicken meat containing formalin using low frequency dielectric method, to determine the value of the electrical capacitance and dielectric constant on chicken marinated in formalin 0 mL, 10 mL, 20 mL, 30 mL, 40 mL and 50 mL, 3 gram of meat soaked in formalin for 1 hour. The electrical characteristics are measured capacitance and dielectric constant. Capacitance is measured using a capacitor plate made of a copper plate with a size of 20 x 10 mm the distance between the plates 5 mm. At the center of the plate in place of chicken and connected to the LCR meter Instek GW-816 series with a double probe L and H, while the dielectric constant obtained from the calculation value capacitance. Capacitance measurements performed with a frequency range of 100 Hz - 2000 Hz at 25 Hz intervals. Result research shows that decline in the value capacitance meat formalin is soaked in 0 mL to 30 mL and a decline in meat is decreases in formalin 30 mL to 50 mL. Value capacitance is inversely proportional to the dielectric constant values. Capacitance value decreases as the frequency of a given.

Key word : Meat chicken, Formaldehyde, Capacitance, Dielectric constant

KATA PENGANTAR

Puji syukur Alhamdulillah penulis ucapkan kepada SWT yang telah melimpahkan rahmat dan hidayah-Nya sehingga paenulis dapat menyelesaikan Tugas Akhir yang berjudul "Analisa Sifat Kelistrikan Daging Ayam Terhadap Penambahan Formalin Dengan Metode Dielektrik". Penulis mengucapkan terima kasih kepada pihak yang telah membantu khususnya kepada

1. Bapak Sukir Maryanto.,PhD selaku ketua jurusan Fisika, Fakultas MIPA Universitas Brawijaya.
2. Bapak Chomsin S. Widodo.,S.Si.,M.Si.,PhD selaku pembimbing pertama atas kesabaran, motivasi, bertukar ide, arahan, dan bimbingan hingga terselesaikannya tugas akhir ini.
3. Bapak A. Hidayat.,S.Si.,M.Si selaku pembimbing kedua yang telah meluangkan waktu dan pikiran, memberi petunjuk, pengetahuan, arahan dan bimbingan kepada penulis.
4. Bapak Drs. Johan A.E.Noor.,M.Sc.,PhD selaku dosen pembimbing akademik yang memberikan masukan berkaitan dengan masalah akademik kepada penulis.
5. Bapak Adi Dan Bapak Robby yang sudah membantu dalam meminjamkan alat-alat yang ada di laboratorium yang digunakan untuk proses penelitian penulis.
6. DIKTI yang telah memberikan beasiswa kepada penulis selama studi, sehingga sangat membantu dalam proses perkuliahaan.
7. Orang tua tercinta Bapak Tumijan dan Ibu Sunarsih yang sudah memberikan kepercayaan, semangat, do'a yang tiada henti, dan kasih sayang kepada penulis.
8. Kakak tersayang Rika Yunita, kedua keponakan Taufik dan Ihsan beserta keluarga besar yang selalu memberikan motivasi, kebahagiaan, kasih sayang dan do'a kepada penulis
9. Bapak/ibu dosen di jurusan fisika yang telah memberikan ilmu yang sangat bermanfaat kepada penulis selama masa perkuliahaan.

10. Teman-teman tugas akhir dielektrik Tasi, Clara dan teman-teman bimbingan bapak Chomsin atas kerjasamanya selama pelaksanaan tugas akhir.
11. Teman – teman fisika 2012 atas kebersamaan selama perkuliahaan.
12. Teman- teman kos Sunan Drajat no 9 yang selalu menghibur penulis.
13. Sahabat tersayang Kekey, Asna, Selly, Dian, Dina, dan Islah yang selalu menghibur penulis.
14. Semua pihak yang telah membantu penulis yang tidak dapat penulis sebut satu per satu.

Penulis menyadari bahwa dalam penuisan skripsi ini masih kurang baik dalam penyusunan, bahasa dan penyajiannya. Oleh karena itu penulis mengharapkan saran dan kritik pembaca sehingga dapat memberikan perubahan kearah yang lebih baik.

Malang, 24 Juli 2016

Penulis

DAFTAR ISI

HALAMAN JUDUL.....	i
LEMBAR PENGESAHAN SKRIPSI.....	iii
LEMBAR PERNYATAAN.....	v
ABSTRAK.....	vii
ABSTRACT.....	ix
KATA PENGANTAR.....	xi
DAFTAR ISI.....	xiii
DAFTAR GAMBAR.....	xv
DAFTAR TABEL.....	xvii
DAFTAR LAMPIRAN.....	xix
BAB I PENDAHULUAN.....	1
1.1 Latar Belakang.....	1
1.2 Perumusan Masalah.....	3
1.3 Batasan Masalah.....	3
1.4 Tujuan Penelitian.....	3
1.5 Manfaat Penelitian.....	4
BAB II TINJAUAN PUSTAKA.....	5
2.1 Biolistrik.....	5
2.2 Kapasitansi.....	5
2.3 Dielektrik.....	6
2.4 Metode Dielektrik.....	8
2.5 Daging Ayam.....	10
BAB III METODE PENELITIAN.....	15
3.1 Tempat dan Waktu Penelitian.....	15

3.2	Alat dan Bahan	15
3.3	Tahapan Penelitian.....	15
3.4	Persiapan Alat Dan Bahan.....	17
3.4.1	Persiapan alat ukur listrik.....	17
3.5	Proses Daging Diformalin.....	19
3.6	Pengukuran Sifat Listrik.....	19
3.7	Analisis Data.....	19
BAB IV HASIL DAN PEMBAHASAN.....		23
4.1	Hasil Penelitian.....	23
4.2	Konstanta dielektrik udara.....	23
4.3	Konstanta Dielektrik.....	25
4.3.1	Perendaman pada 0 mL formalin.....	26
4.3.2	Perendaman pada 10 mL formalin.....	29
4.3.3	Perendaman pada 20 mL formalin.....	32
4.3.4	Perendaman pada 30 mL formalin.....	34
4.3.5	Perendaman pada 40 mL formalin.....	37
4.3.6	Perendaman pada 50 mL formalin.....	39
4.3.7	Perendaman daging ayam pada formalin.....	41
4.4	Faktor Faktor yang Mempengaruhi Nilai Konstanta Dielektrik.....	44
BAB V PENUTUP.....		47
5.1	Kesimpulan.....	47
5.2	Saran.....	47
DAFTAR PUSTAKA.....		49
LAMPIRAN.....		51

DAFTAR GAMBAR

Gambar 2. 1	Proses polarisasi pada bahan dielektrik akibat medan listrik luar	7
Gambar 2. 2	Plat Paralel Sebelum Terhubung dengan Sumber tegangan	7
Gambar 2. 3	Plat Paralel sesudah terhubung dengan Sumber Tegangan	8
Gambar 2. 4	Gambar rangkaian alat penelitian	10
Gambar 2. 5	Gambar Struktur Formalin	12
Gambar 3. 1	Diagram alir penelitian	16
Gambar 3. 2	Proses Zeroing	18
Gambar 3. 3	Diagram Prosedur perlakuan Penelitian	21
Gambar 4. 1	Grafik hubungan antara konstanta dielektrik udara dengan frekuensi	24
Gambar 4. 2	Gambar 4.2 Gambar grafik hubungan antara konstanta dielektrik daging ayam tanpa formalin (0 mL) terhadap penambahan frekuensi	28
Gambar 4. 3	Gambar 4.3 Grafik hubungan antara konstanta dielektrik daging ayam yang direndam formalin 10 mL terhadap penambahan frekuensi	31
Gambar 4. 4	Gambar 4.4 Grafik hubungan antara konstanta dielektrik daging ayam yang direndam formalin 20 mL terhadap penambahan frekuensi	33
Gambar 4. 5	Gambar 4.5 Grafik hubungan antara konstanta dielektrik daging ayam, yang direndam formalin 30 mL terhadap penambahan frekuensi	36
Gambar 4. 6	Grafik hubungan antara konstanta dielektrik daging ayam yang direndam formalin 40 mL terhadap penambahan frekuensi	38
Gambar 4. 7	Grafik hubungan antara konstanta dielektrik daging ayam yang direndam formalin 50 mL terhadap penambahan frekuensi	40
Gambar 4. 8	Grafik hubungan antara frekuensi dengan konstanta dielektrik daging ayam pada rendaman formalin	43
Gambar 4. 9	Grafik konstanta dielektrik pada frekuensi sama (1000 Hz) dengan penambahan formalin	45

DAFTAR TABEL

Tabel 2. 1	Tabel konstanta dielektrik	13
Tabel 4. 1	Tabel persamaan garis pada grafik hubungan frekuensi dan konstanta dielektrik pada perendaman formalin 0 mL	27
Tabel 4. 2	Tabel persamaan garis pada grafik hubungan frekuensi dan konstanta dielektrik pada perendaman formalin 10 mL	29
Tabel 4. 3	Tabel persamaan garis pada grafik hubungan frekuensi dan konstanta dielektrik pada daging yang direndam formalin 20 mL	32
Tabel 4. 4	Tabel persamaan garis pada grafik hubungan frekuensi dan konstanta dielektrik pada daging yang direndam formalin 30 mL	35
Tabel 4. 5	Tabel persamaan garis pada grafik hubungan frekuensi dan konstanta dielektrik pada perendaman formalin 40 mL	37
Tabel 4. 6	Tabel persamaan garis pada grafik hubungan frekuensi dan konstanta dielektrik pada perendaman formalin 50 mL	39
Tabel 4. 7	Tabel persamaan garis pada grafik hubungan frekuensi dan konstanta dielektrik	41

DAFTAR LAMPIRAN

Lampiran 1. 1 Gambar cara kalibrasi LCR Meter.....	51
Lampiran 1. 2 Alat Dan Bahan.....	52
Lampiran 1. 3 Data penelitian.....	54

BAB I

PENDAHULUAN

1.1 Latar Belakang

Biolistrik merupakan karakteristik kelistrikan dari sel pada makhluk hidup. Karakteristik biolistrik yang dapat diamati antara lain: impedansi, kapasitansi, induktansi, konstanta dielektrik dan konduktivitas listrik. Karakteristik biolistrik dapat diukur dengan metode dielektrik. Pengukuran dielektrik yaitu metode yang dilakukan dengan menggunakan dua plat kapasitor. Diantara plat kapasitor tersebut disisipkan bahan dielektrik yang akan diuji karakteristik biolistriknnya. Setiap bahan memiliki sifat listrik yang khas dan besarnya sangat ditentukan oleh kondisi internal bahan tersebut, seperti momen dipol listrik, komposisi bahan kimia, kandungan air, keasamaan dan sifat internal lainnya (Hermawan 2005). Bahan yang memiliki sifat kelistrikan dan mampu menyimpan energi listrik disebut dengan bahan dielektrik (Frenske & Mirsa 2000). Selain itu metode dielektrik juga dapat dimanfaatkan untuk pengukuran kadar air secara non destruktif pada level energi yang rendah (Kato 1997).

Ayam adalah hewan unggas yang sering ditenakkan dan dikonsumsi. Manfaat makan daging ayam, ayam merupakan salah satu bahan makanan berprotein tinggi. Ayam bukan hanya sumber protein yang sangat baik, tetapi juga merupakan sumber vitamin dan mineral yang sangat baik juga. Vitamin dan mineral yang ditemukan pada ayam sangat banyak, dan berguna untuk berbagai proses dalam tubuh. Misalnya, vitamin B berguna untuk katarak, gangguan kulit, kekebalan tubuh, kelemahan, pencernaan, sistem saraf, migrain, gangguan jantung, rambut beruban, kolesterol tinggi, diabetes, dan lain sebagainya. Vitamin D membantu penyerapan kalsium dan menguatkan tulang. Vitamin A membantu menjaga penglihatan mata, dan mineral seperti zat besi sangat membantu untuk pembentukan hemoglobin, aktivitas otot, mencegah anemia.

Akhir-akhir ini banyak ditemukan makanan dan bahkan daging ayam yang mengandung formalin. Tentu hal ini sangat mengkhawatirkan, karena formalin bukanlah zat aditif makanan, namun justru dapat mengancam kesehatan bila dikonsumsi. Formalin sudah sangat umum digunakan dalam kehidupan sehari-hari. Formalin merupakan larutan tak berwarna, mudah larut, terkandung sekitar 37% formaldehid dalam air. Biasanya ditambah metanol hingga 15% sebagai pengawet. Formaldehid biasanya dimanfaatkan untuk pembersih lantai, kapal, pakaian, pembasmi lalat dan berbagai jenis serangga. Ternyata formalin disalahgunakan untuk keperluan lain seperti pengawetan makanan yang sangat tidak baik apabila dikonsumsi oleh tubuh manusia. Ternyata sekarang ini ada beberapa penjual yang curang, seperti penjual daging ayam agar daging ayamnya awet, menggunakan bahan pengawet formalin. Formalin sangat berbahaya jika dihirup, mengenai kulit dan tertelan. Jika dikonsumsi dalam jangka panjang maka formaldehid dapat merusak hati, ginjal, limpa, dan pancreas bahkan dapat menyebabkan kanker.

Dalam penelitian ini menggunakan alat LCR meter, LCR meter adalah bagian dari peralatan tes elektronik yang digunakan untuk mengukur induktansi (L), kapasitansi (C), dan resistansi (R) dari komponen. Dalam versi sederhana dari nilai-nilai alat ini sebenarnya dari kuantitas ini tidak diukur, melainkan dengan impedansi yang diukur secara internal dan dikonversi untuk ditampilkan dengan kapasitansi yang sesuai atau nilai induktansi. Bacaan akan cukup akurat jika kapasitor atau induktor perangkat yang diuji tidak memiliki komponen resistif signifikan impedansi.

Berdasarkan pengertian di atas adalah hal yang mendasari saya melakukan penelitian berkaitan dengan "*Analisa Sifat Kelistrikan Daging Ayam Terhadap Penambahan Formalin dengan Metode Dielektrik*". Dalam penelitian ini dipilih daging ayam karena daging ayam yang banyak dijumpai dipasaran dan sering dikonsumsi oleh banyak orang karena harganya yang murah. Dalam penelitian ini menggunakan formalin sebagai subyek penelitian, karena yang diteliti adalah konstanta dielektrik daging ayam yang mengandung

formalin. Penelitian ini juga menggunakan sebuah alat yaitu LCR meter. Perendaman daging ayam pada larutan formalin memungkinkan akan mempengaruhi karakteristik biolistrik dan konstanta dielektrik daging ayam tersebut. Oleh karena itu pada penelitian ini dilakukan beberapa perlakuan perendaman pada larutan formalin dengan konsentrasi berbeda-beda yaitu 10 mL, 20 mL, 30 mL, 40 mL, dan 50 mL, yang diukur meliputi nilai kapasitansi, resistansi, induktansi dan konstanta dielektrik dari daging ayam tersebut.

1.2 Perumusan Masalah

Berdasarkan latar belakang di atas, dapat dirumuskan masalah sebagai berikut

- a. Bagaimana pengaruh penambahan formalin pada daging ayam terhadap nilai kapasitansi dan konstanta dielektrik?
- b. Bagaimana perbedaan nilai kapasitansi dan konstanta dielektrik pada daging ayam yang diberi formalin dan daging ayam yang tidak diberi formalin?

1.3 Batasan Masalah

Berdasarkan berbagai masalah yang ada perlu dibuat pembatasan masalah supaya permasalahan yang akan dibahas tidak meluas. Oleh karena itu, peneliti membatasi masalah sebagai berikut:

- a. Obyek penelitian adalah Daging Ayam.
- b. Subjek penelitian adalah Formalin.
- c. Parameter dalam penelitian ini adalah meliputi : nilai kapasitansi (C), dan nilai Konstanta Dielektrik.

1.4 Tujuan Penelitian

Tujuan dari penelitian ini antara lain,

- a. Mengetahui pengaruh penambahan formalin pada daging ayam terhadap nilai kapasitansi dan konstanta dielektrik.

- b. Mengetahui perbedaan nilai kapasitansi dan konstanta dielektrik pada daging ayam yang diberi formalin dan daging ayam yang tidak diberi formalin.

1.5 Manfaat Penelitian

Dengan dilaksanakan penelitian ini diharapkan mampu memberikan manfaat diantaranya,

- a. Memberikan informasi bagi peneliti dan pembaca tentang pengaruh penambahan formalin pada daging ayam terhadap nilai kapasitansi dan konstanta dielektrik.
- b. Menambah pengetahuan bagi peneliti dan pembaca tentang perbedaan nilai kapasitansi dan konstanta dielektrik pada daging ayam yang diberi formalin dan daging ayam yang tidak diberi formalin.

BAB II

TINJAUAN PUSTAKA

2.1 Biolistrik

Biolistrik merupakan karakteristik kelistrikan dari sel atau jaringan yang dihasilkan oleh berbagai peristiwa pada makhluk hidup yang dipengaruhi oleh senyawa metabolisme pada makhluk hidup dan pertukaran ion yang terjadi. Karakteristik biolistrik tersebut dapat diamati dengan menggunakan metode dielektrik. Sebagian besar bahan biologis termasuk dielektrik dan juga memiliki karakteristik biolistrik. Banyak variabel yang bisa digunakan untuk menentukan karakteristik biolistrik. Karakteristik biolistrik bahan yang dapat diamati di antaranya kapasitansi, resistansi, induktansi, dan impedansi.

2.2 Kapasitansi

Kapasitansi adalah ukuran jumlah muatan listrik yang disimpan (atau dipisahkan) untuk sebuah potensial listrik yang telah ditentukan. Bentuk paling umum dari piranti penyimpanan muatan adalah sebuah kapasitor dua lempeng/pelat/keping. Jika muatan di lempeng/pelat/keping adalah $+Q$ dan $-Q$, dan V adalah tegangan listrik antar lempeng (pelat) atau keping. Sedangkan kapasitor adalah piranti yang berguna untuk menyimpan muatan dan energi. Kapasitor terdiri dari dua konduktor yang berdekatan tetapi terisolasi satu sama lain dan membawa muatan yang sama besar dan berlawanan. Kapasitor memiliki banyak kegunaan, kapasitor juga digunakan untuk, memperhalus getaran yang timbul ketika arus bolak balik dikonversi menjadi arus searah pada catu daya. Hubungan antara kapasitansi dan frekuensi dapat terlihat pada rumus berikut,

$$Z = \sqrt{R^2 + (X_L - X_C)^2}$$

atau

$$Z = \sqrt{R^2 + (2\pi fL - 1/2\pi fC)^2}$$

Dimana,

Z = impedansi (Ω)

R = hambatan (Ω)

X_L = reaktansi induktif (Ω)

X_C = reaktansi kapasitif (Ω)

f = frekuensi (Hz)

L = induktansi (H)

C = kapasitas kapasitor (F) (Giancoli 2001)

2.3 Dielektrik

Dielektrik adalah sejenis bahan Isolator listrik yang dapat dikutubkan (*polarized*) dengan cara menempatkan bahan dielektrik dalam medan listrik. Ketika bahan ini berada dalam medan listrik, muatan listrik yang terkandung di dalamnya tidak akan mengalir, sehingga tidak timbul arus seperti bahan konduktor, tapi hanya sedikit bergeser dari posisi setimbangnya mengakibatkan terciptanya *pengutuban dielektrik*. Oleh karena pengutuban dielektrik, muatan positif bergerak menuju kutub negatif medan listrik, sedang muatan negatif bergerak pada arah berlawanan (yaitu menuju kutub positif medan listrik). Hal ini menimbulkan medan listrik internal (di dalam bahan dielektrik) yang menyebabkan jumlah keseluruhan medan listrik yang melingkupi bahan dielektrik menurun. Jika bahan dielektrik terdiri dari molekul-molekul yang memiliki ikatan lemah, molekul-molekul ini tidak hanya menjadi terkutub, namun juga sampai bisa tertata ulang sehingga sumbu simetrinya mengikuti arah medan listrik. Dielektrik dapat memperlemah medan listrik di antara muatan positif dan negative pada plat kapasitor. Molekul polar di dalam dielektrik dengan momen dipol permanen yang tersebar secara

acak akan menyearahkan diri dengan arah medan listrik luar seperti pada Gambar 2.1 berikut,

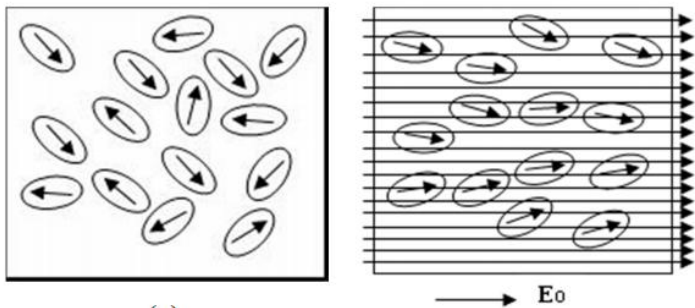

Gambar 2. 1 Proses polarisasi pada bahan dielektrik akibat medan listrik luar.

Bahan dielektrik adalah bahan yang jika tidak terdapat medan listrik bersifat isolator, namun jika ada medan listrik yang melewatinya, maka akan terbentuk dipol-dipol listrik, yang arah medan magnetnya melawan medan listrik semula.

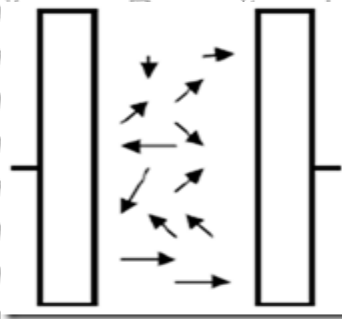

Gambar 2. 2 Plat Paralel Sebelum Terhubung dengan Sumber tegangan

Dua plat paralel sebelum terhubung ke sumber tegangan. Sebelum adanya muatan pada kedua pelat, bahan dielektrik memiliki

dipol acak sehingga bersifat isolator. Setelah plat bermuatan yang menghasilkan medan listrik ke arah kanan, muatan pada dielektrik terpolarisasi oleh medan listrik. Muatan positif perlahan-lahan menuju plat negatif, dan muatan negatif ke plat positif. Akibatnya terdapat medan listrik baru pada dielektrik yang melawan medan listrik semula yang saling menghilangkan, sehingga medan listrik total menjadi nol, dan arus berhenti mengalir.

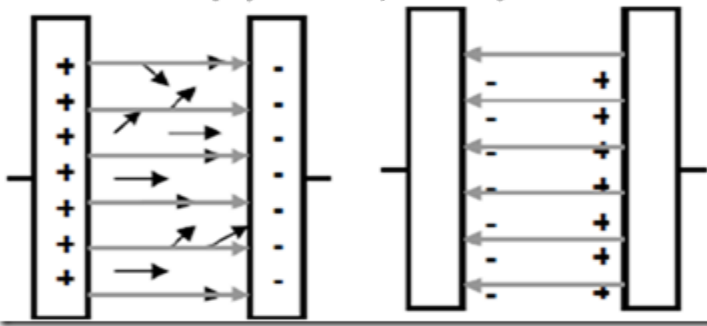

Gambar 2. 3 Plat Paralel sesudah terhubung dengan Sumber Tegangan

Pengukuran sifat dielektrik merupakan aplikasi teori elektromagnetik yang dapat dikembangkan untuk mengetahui kualitas bahan biomaterial tanpa harus merusak produk tersebut. Sifat dielektrik menggambarkan kemampuan suatu bahan untuk menyimpan, mentransmisikan dan memantulkan energi gelombang elektromagnetik. Setiap bahan biomaterial memiliki sifat dielektrik tersendiri dan besarnya dipengaruhi oleh kandungan airnya. Sifat ini semakin banyak dimanfaatkan untuk optimasi kualitas bahan pangan dalam proses pengeringan, pemanasan, dan sterilisasi (Gulita 2015).

2.4 Metode Dielektrik

Metode dielektrik merupakan metode secara langsung menggunakan dua buah plat penghantar dimana terdapat bahan

dielektrik diantaranya. Metode dielektrik juga merupakan suatu metode berbasis listrik yang bisa digunakan untuk mendeteksi kemurnian bahan. Metode dielektrik dapat digunakan untuk menentukan karakteristik biolistrik suatu bahan.

Pengukuran sifat biolistrik adalah salah satu cara untuk mengetahui karakteristik kelistrikan dari suatu sel atau jaringan. Karakteristik kelistrikan pada suatu sel dan pengukuran sifat biolistrik telah banyak dilakukan dengan beberapa metode antara lain; Electrochemical impedance spectroscopy (EIS), Kromatografi pertukaran ion, Total body electrical conductivity (TOBEC), Bioelektrikal impedance analysis (BIA) dan Potentiometric sensor dengan elektroda emas dan perak. Metode pengukuran sifat listrik pada frekuensi tinggi untuk penentuan nilai dielektrik dengan memanfaatkan sensor TDR dan kabel coaxial. Pengukuran sifat listrik dengan sinyal frekuensi rendah juga telah dilakukan untuk menguji keterkaitan dielektrik dengan kadar air.

Metode - metode di atas memang sering digunakan untuk mengukur sifat biolistrik pada kisaran frekuensi tertentu. Metode dielektrik yang digunakan pada penelitian ini merupakan metode yang dianggap paling efisien dan cepat. Metode dielektrik merupakan pengukuran secara langsung, dimana objek yang akan diukur (biasanya berupa membrane, ataupun lapisan) diletakkan diantara dua plat kapasitor yang terbentuk dari tembaga. Objek yang akan diukur bertindak sebagai bahan dielektrik yang berada diantara plat kapasitor dan dapat diukur kapasitansi dan impedansi dari bahan dengan frekuensi tertentu. Pada penelitian ini digunakan frekuensi rendah (low frequency), dikarenakan pada frekuensi rendah yaitu tepatnya 1 KHz menurut Mastisen (2000) merupakan frekuensi terbaik yang telah disesuaikan untuk pengukuran dielektrik dengan penyajian pengukuran bahan yang dijepit dengan dua plat tembaga. Menurut Martisen (2008) jaringan akan bersifat dielektrik pada frekuensi rendah yaitu $10 \text{ Hz} < 50 \text{ kHz}$ dan jaringan akan bersifat konduktor pada frekuensi tinggi ($< 100 \text{ kHz}$). Oleh karena itu pada metode dielektrik ini digunakan frekuensi rendah pada kisaran 100 Hz – 2000 Hz dengan interval 25 Hz. Skema metode dielektrik yang

dilakukan dengan pengukuran awal yaitu kapasitansi dan impedansi dengan menggunakan LCR meter, kemudian dari nilai kapasitansi dan impedansi yang didapat dapat dihitung konduktivitasnya dan konstanta dielektrik. Pengukuran yang dilakukan seperti pada gambar 2.4

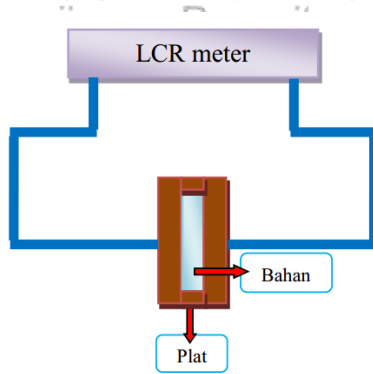

Gambar 2. 4 Gambar rangkaian alat penelitian

Penggunaan plat paralel dari kapasitor buatan dan pemberian input sumber tegangan pada LCR meter dapat terukur nilai kapasitansi dari bahan. Ketika nilai kapasitansi dari plat tersebut pada kondisi ruang vakum dan udara, terukur kapasitansinya sebagai C_0 . Jika pada plat tersebut disisipkan bahan sebagai bahan dielektrik.

2.5 Daging Ayam

Daging ayam merupakan sumber protein yang mudah mengalami kerusakan oleh mikro organisme. Kerusakan terjadi diakibatkan adanya mikroorganisme kontaminan pada daging. Salah satu faktor yang menentukan tingkat kerusakan daging adalah jumlah mikroorganisme kontaminan. Semakin besar jumlah mikroorganisme kontaminan, maka akan semakin cepat terjadinya kerusakan pada daging dengan diproduksinya senyawa-senyawa yang tidak diinginkan.

Daging ayam adalah bahan pangan yang bernilai gizi tinggi karena kaya akan protein, lemak, mineral serta zat lainnya yang sangat dibutuhkan tubuh. Usaha penyediaan daging memerlukan perhatian khusus karena daging mudah dan cepat tercemar oleh pertumbuhan mikroorganisme. Daging sangat baik bagi pertumbuhan dan perkembangbiakan mikroorganisme sehingga dapat menurunkan kualitas daging. Penurunan kualitas daging diindikasikan melalui perubahan warna, rasa, aroma bahkan pembusukan. Daging yang merupakan sumber protein mudah dan sering mengalami kerusakan oleh mikroba. Daging merupakan bahan pangan yang penting dalam memenuhi kebutuhan gizi. Selain mutu proteinnya tinggi, pada daging terdapat pula kandungan asam amino esensial yang lengkap dan seimbang. Keunggulan lain, protein daging lebih mudah dicerna dibanding dengan yang berasal dari nabati. Bahan pangan ini juga mengandung beberapa jenis mineral dan vitamin. Selain dalam bentuk segar, daging juga dapat dikonsumsi dalam berbagai produk olah (Dwiatmaja 2013).

2.4 Formalin

Formalin adalah larutan tidak berwarna dan berbau tajam menusuk, mengandung sekitar 30 – 50% formaldehid (HCHO) dalam air, biasanya ditambahkan metanol 0,5 – 10% sebagai stabilisator untuk mencegah polimerisasi. Formaldehida dalam bentuk murni (100%) tidak tersedia karena pada suhu dan tekanan normal mudah mengalami polimerisasi membentuk padatan (Windholz 1989).

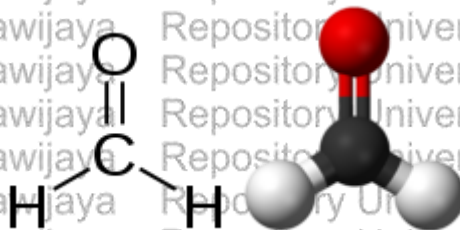

Gambar 2. 5 Gambar Struktur Formalin

Formalin merupakan larutan jernih tidak berwarna, berbau tajam, mengandung senyawa formaldehid (HCO) sekitar 37 persen dalam air. Formalin mempunyai banyak nama atau sinonim, seperti formol, morbidic, methanal, formicaldehyde, methyl oxide, oxymethylene, methylaldehyde, oxomethane, formoform, formalith, oxomethane, karsan, methylene glycol, paraforin, poly oxymethylene glycols, superlysoform, tetraoxymethylene dan trioxane. Formalin sering digunakan sebagai desinfektan, dan bersifat toksik bagi kita karena apabila terisap bisa menyebabkan iritasi kepala serta keluar air mata, dan pusing. Senyawa formaldehid di dalam tubuh manusia dikonversi menjadi asam format yang dapat meningkatkan keasaman darah. Apabila terminum, maka mulut, tenggorokan dan perut terasa terbakar, sakit menelan, mual, muntah, dan diare, kemungkinan terjadi pendarahan, sakit perut yang hebat, sakit kepala, hipotensi (tekanan darah rendah), kejang, tidak sadar hingga koma, bahkan dapat menyebabkan kematian. Selain itu juga dapat terjadi kerusakan hati, jantung, otak, limpa, pankreas, system susunan saraf pusat dan ginjal. formalin di dalam jaringan tubuh bisa menyebabkan terikatnya DNA oleh formalin, sehingga mengganggu ekspresi genetik yang normal.

2.5 Konstanta Dielektrik

Konstanta dielektrik K adalah sebuah bilangan murni, karena C selalu lebih besar daripada C_0 , maka nilai K selalu lebih besar dari pada satu. Tidak ada dielektrik yang benar - benar merupakan isolator sempurna. Maka selalu ada arus yang bocor di antara plat-plat bermuatan dari sebuah kapasitor dengan sebuah dilektrik. Untuk ruang hampa, $K = 1$ sebagai ketetapan. Untuk udara pada suhu dan tekanan biasa, K kira-kira sebesar 1,0006, ini hampir sama dengan 1 sehingga untuk kebanyakan tujuan sebuah kapasitor udara adalah ekuivalen dengan kapasitor dalam perhatian bahwa kendati air mempunyai nilai K yang sangat besar, namun air biasanya bukan merupakan sebuah dielektrik yang sangat praktis untuk digunakan dalam kapasitor. Alasannya adalah bahwa selain air murni merupakan

konduktor yang sangat buruk, air juga merupakan pelarut ion yang istimewa. Setiap ion yang larut dalam air akan menyebabkan muatan mengalir diantara plat-plat kapasitor, sehingga kapasitor itu akan mengosongkan muatan. Tidak ada dielektrik yang benar-benar merupakan isolator sempurna. Berikut table konstanta dielektrik

Tabel 2. 1 Tabel konstanta dielektrik

Material	K (konstanta dielektrik)
Ruang hampa	1
Udara (1 atm)	1,00059
Udara (100 atm)	1,0548
Telfon	2,1
Polietilena	2,25
Benzene	2,28
Milka	3-6
Polivinil klorida	3,1
Pleksiglas	3,14
Kaca	5-10
Neoprena	6,70
Germanium	16
Gliserin	42,5
Air	80,4
Strontium titanat	310
Karet	2-3,5
Kertas	3,5

(Young & Freedman 2000: Halliday & Resnick 2000)

(halaman ini sengaja dikosongkan)

BAB III

METODE PENELITIAN

3.1 Tempat dan Waktu Penelitian

3.1.1 Tempat Penelitian

Penelitian ini dilaksanakan di Laboratorium Biofisika dan di Laboratorium Instrumentasi Pengukuran Jurusan Fisika Fakultas Matematika Dan Ilmu Pengetahuan Alam Universitas Brawijaya Malang.

3.1.2 Waktu Penelitian

Waktu pelaksanaan penelitian tugas akhir ini pada bulan Maret – Juni 2016.

3.2 Alat dan Bahan

Alat yang digunakan adalah LCR meter, LCR konektor L dan H, Plat Kapasitor, Alat Pemotong PCB, Labu Ukur, Pisau, Neraca Digital, Stopwatch, Penggaris, Gelas Ukur, Pipet Ukur, Jangka Sorong, Lem Alteco, Plastic Klip, Gunting, Kabel Tunggal, dan Solder.

Bahan yang digunakan adalah daging ayam, dan formalin. Sampel uji yang digunakan dalam penelitian ini adalah daging ayam yang diperoleh dari agen daging ayam pasar merjosari kota Malang, dan formalin yang diperoleh dari toko bahan kimia “Makmur Sejati”.

3.3 Tahapan Penelitian

Penelitian ini dilakukan dengan beberapa tahap dan perlakuan dalam pengukuran karakteristik pada daging ayam yang direndam formalin dengan menggunakan metode dielektrik. Tahapan yang dilakukan antara lain studi literature, persiapan alat dan bahan yang meliputi persiapan alat ukur, sifat listrik dan persiapan sampel dan analisis data. Berikut diagram alir dari penelitian ini seperti pada gambar 3.1.



Gambar 3.1 Diagram alir penelitian

3.4 Persiapan Alat Dan Bahan

Peralatan yang digunakan pada penelitian ini yaitu LCR meter GW-Instek seri 816, LCR konektor L dan H, PCB tembaga jenis fiber optic, solder, kawat tembaga, jangka sorong, kabel tunggal, penggaris, alteco, gunting, pisau, gelas ukur 10 mL, pipet, kertas alumuniumfoil, gelas ukur 200 mL, dan neraca analitik. bahan yang digunakan meliputi daging ayam dan formalin. Peralatan disiapkan untuk melakukan langkah-langkah berikut,

3.4.1 Persiapan alat ukur listrik

Persiapan alat ukur listrik dilakukan dengan beberapa tahap yaitu pembuatan plat kapasitor, pengaturan dan perancangan sistem, pengujian sistem.

a. Pembuatan plat kapasitor

Pembuatan plat kapasitor didesain menggunakan dua buah keping PCB tembaga jenis fiber optic dengan ukuran 20 mm x 10 mm yang diletakkan secara sejajar dengan jarak 5 mm menggunakan bahan isolator. Plat dibuat dari lempengan tembaga yang dipotong berdasarkan ukuran yang telah ditentukan. Setelah ukuran ditentukan, plat kapasitor PCB dipotong menggunakan alat pemotong PCB atau dapat menggunakan gunting. Bagian PCB yang mempunyai panjang berukuran 20 mm dilakukan penambahan 2 mm untuk di sambungkan dengan kabel yang disolder langsung pada plat. Potongan PCB yang sesuai ukuran yang digunakan, kemudian potongan PCB tersebut direkatkan berbentuk balok menggunakan alteco.

Penyambungan plat kapsitor dengan kabel berfungsi sebagai penghubung antara plat kapasitor dengan konektor LCR meter L dan H yang akan disambungkan dengan penjepit yang ada pada konektor. Selanjutnya, LCR meter di rangkai konektor dual probe dimana konektor LCR meter dipasangkan sesuai dengan tanda L dan H. Pada

saat pemasangan harus dipastikan bahwa konektor tersambung dan terkunci dengan benar.

b. Pengaturan perancangan system

Pengaturan perancangan system pada LCR meter meliputi kalibrasi, Zeroing dan Warming. Terlebih dulu LCR meter dihidupkan, lalu dilakukan kalibrasi pada LCR meter dengan cara menekan menu, pilih setting dan tekan recall calibration, ditunggu sampai bar hitam penuh dan muncul tulisan Ok. Pada LCR meter, Zeroing dilakukan dengan cara pilih open test, yang dimaksud dengan open test adalah keadan dimana kabel konektor L dan H tidak tersambung dengan apapun tahap Zeroing berikutnya yaitu short test dimana kabel konektor L dan H disambungkan dengan kawat tembaga yang pendek, ditunggu sampai bar hitam penuh dan muncul tanda Ok. Zeroing pada LCR meter dilakukan agar pengukuran yang dilakukan tidak terjadi error dari kabel konektor L dan H dan hasilnya lebih akurat.

Proses Warming up dilakukan dengan cara mereset value atau besaran yang akan diukur. Proses ini berfungsi untuk pemasaran alat agar dalam pengukuran menggunakan LCR meter ini yaitu besaran kapasitansi dan resistansi. Pengukuran dilakukan dengan kecepatan pengukuran lambat pada suatu komponen yang sudah diketahui besarnya kapasitansi dan resistansinya.

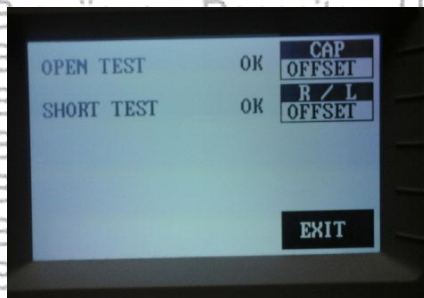

Gambar 3. 2 Proses Zeroing

3.5 Proses Daging Diformalin

Daging ayam dipotong dengan massa sebesar 3 gr, sebanyak 24 potong. Empat potong untuk pemberian formalin 0 mL, 4 potong untuk pemberian 10 mL formalin, 4 potong untuk pemberian 20 mL formalin, 4 potong untuk pemberian 30 mL formalin, 4 potong untuk pemberian 40 mL formalin, dan 4 potong untuk pemberian 50 mL formalin. Daging ayam yang diberi formalin 0 mL atau yang tidak diberi formalin sebagai variable kontrol. Perlakuan untuk daging yang diberi formalin direndam dalam formalin 10 mL, 20 mL, 30 mL, 40 mL, dan 50 mL masing-masing selama 1 jam sedangkan untuk yang kontrol atau daging yang tidak diberi formalin hanya didiamkan selama 1 jam sebelum dilakukan pengukuran. Saat daging sudah direndam dengan formalin selama 1 jam, daging di angkat dari rendaman formalin lalu dikeringkan dengan tisu kurang lebih 2 menit, daging ayam tersebut setelah dikeringkan diletakkan diantara plat kemudian diukur pada LCR meter untuk mengetahui nilai kapasitansi.

3.6 Pengukuran Sifat Listrik

Sampel yang telah siap dimasukkan kedalam plat tembaga dengan ukuran 20 mm x 10 mm yang berjarak 5 mm. Plat kapasitor dihubungkan dengan penjepit pada konektor LCR meter. Plat kapasitor dengan LCR meter untuk mengukur sifat listrik sampel meliputi kapasitansi (nF) dan konstanta dielektrik. Pengukuran dilakukan disuhu ruang sekitar 27 °C. Pengukuran kapasitansi Nilai kapasitansi diukur dalam rentang frekuensi mulai dari 100 Hz sampai 2000 Hz dengan perubahan frekuensi setiap 25 Hz. Dilakukan pengukuran kapasitansi sebanyak 5 kali pengulangan pada setiap sampel dan dalam 1 perlakuan terdapat 4 sampel.

3.7 Analisis Data

Dari hasil pengukuran sifat listrik daging ayam yang direndam pada formalin, formalin yang digunakan yaitu 0 mL, 10 mL, 20 mL, 30 mL, 40 mL, dan 50 mL didapatkan data nilai kapasitansi. Hasil lima kali pengukuran kapasitansi dapat dihitung rata-rata dari nilai

kapasitansinya. Dari nilai kapasitansi yang diukur dan dihitung dapat dihasilkan nilai rata-rata kapasitansi. Setelah didapat hasil pengukuran meliputi kapasitansi (C), luas penampang plat kapasitor tembaga (A), jarak antar plat (d), dan besar permitivitas udara yaitu $\epsilon' = 8,85 \times 10^{-12}$ F/m dapat dilakukan perhitungan untuk mencari nilai konstanta dielektrik. Analisis data yang dilakukan bertujuan untuk menggambarkan hubungan antar listrik konstanta dielektrik yang didapat dengan frekuensi pengukuran. Nilai konstanta dielektrik diplotkan terhadap frekuensi. Dilakukan analisa dengan metode trenline untuk mengetahui kecenderungan hubungan data antara konstanta dielektrik dengan frekuensi yang selanjutnya akan dikomprasikan dengan teori dari literature yang ada. Pengambilan data yaitu nilai kapsitansi dilakukan 5 kali pengukuran pada 1 sampel, dalam 1 perlakuan terdapat 4 sampel. Didapatkan nilai kapasitansi kemudian menghitung nilai konstanta dengan rumus konstanta dielektrik sebagai berikut,

$$\epsilon' = \frac{C \cdot d}{\epsilon_0 A} \quad (3.1)$$

Dimana :

C = Kapasitansi rata-rata (F)

A = Luas penampang plat kapsitor (m)

D = jarak antar plat (m)

ϵ_0 = Permitivitas udara = $8,85 \times 10^{-12}$ F/m

ϵ' = Konstanta Dielektrik

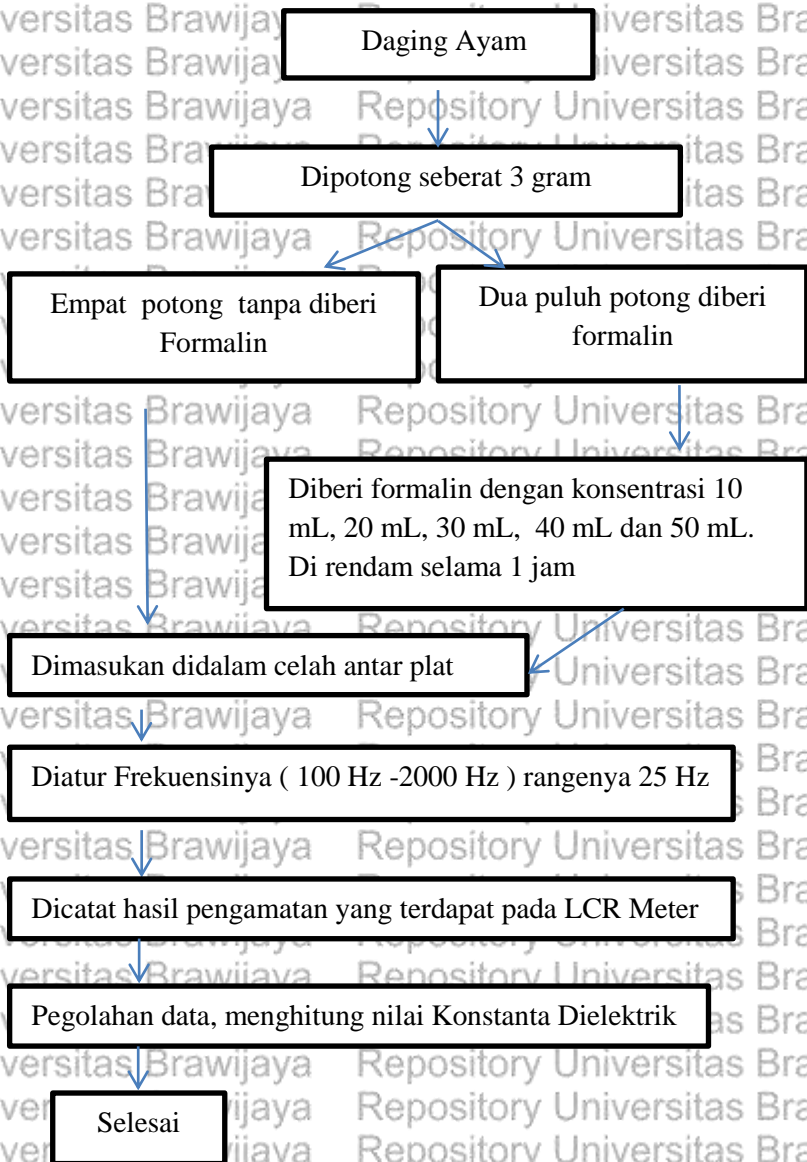

Gambar 3. 3 Diagram Prosedur perlakuan Penelitian

(Halaman ini sengaja dikosongkan)

BAB IV

HASIL DAN PEMBAHASAN

4.1 Hasil Penelitian

Penelitian ini dilakukan untuk mengetahui pengaruh penambahan pemberian formalin pada daging ayam. Penelitian dilakukan dengan persiapan alat seperti mengkalibrasi alat terlebih dahulu, berikut hasil dari pengukuran penelitian yang telah dilakukan didapatkan nilai kapasitansi, dari nilai kapasitansi tersebut dapat dihitung untuk mengetahui nilai konstanta dielektriknya. Tentunya dengan mengetahui nilai luas penampang plat kapasitor, jarak antar plat dan nilai permitivitas udara.

4.2 Konstanta dielektrik udara

Hasil pengujian menggunakan plat kapsitor yang berukuran 20 mm x 10 mm dan dengan jarak antar plat 5 mm, dengan menggunakan alat uji LCR metre GW-instek seri 816 didapatkan nilai konstanta dielektrik udara pada berbagai frekuensi seperti yang terlihat pada gambar 4.1

Gambar 4.1 menunjukkan hubungan antara nilai konstanta dielektrik terhadap frekuensi. Nilai konstanta dielektrik mengalami penurunan dengan bertambahnya nilai frekuensi yang diberikan. Hal tersebut terjadi dikarenakan nilai konstanta dielektrik berbanding terbalik dengan nilai frekuensi. Acuan yang digunakan untuk pengujian alat yang akan digunakan untuk mengukur nilai kapasitansi dan konstanta dielektrik dari daging ayam adalah hasil dari pengukuran nilai konstanta dielektrik udara. Halliday (1992) menyatakan bahwa nilai konstanta udara pada ruang hampa yaitu 1 dan konstanta dielektrik udara pada frekuensi di bawah 1000 Hz yaitu sebesar 1,00054 (Halliday 1992). Sedangkan pengukuran plat pada penelitian ini, pada frekuensi 1000 Hz nilai konstanta dielektrik yaitu paling mendekati yaitu 1.005. Didapatkan nilai persamaan garis regresinya adalah $Y = 10,095e^{-0,002X}$ dengan nilai $R = 0,9516$.

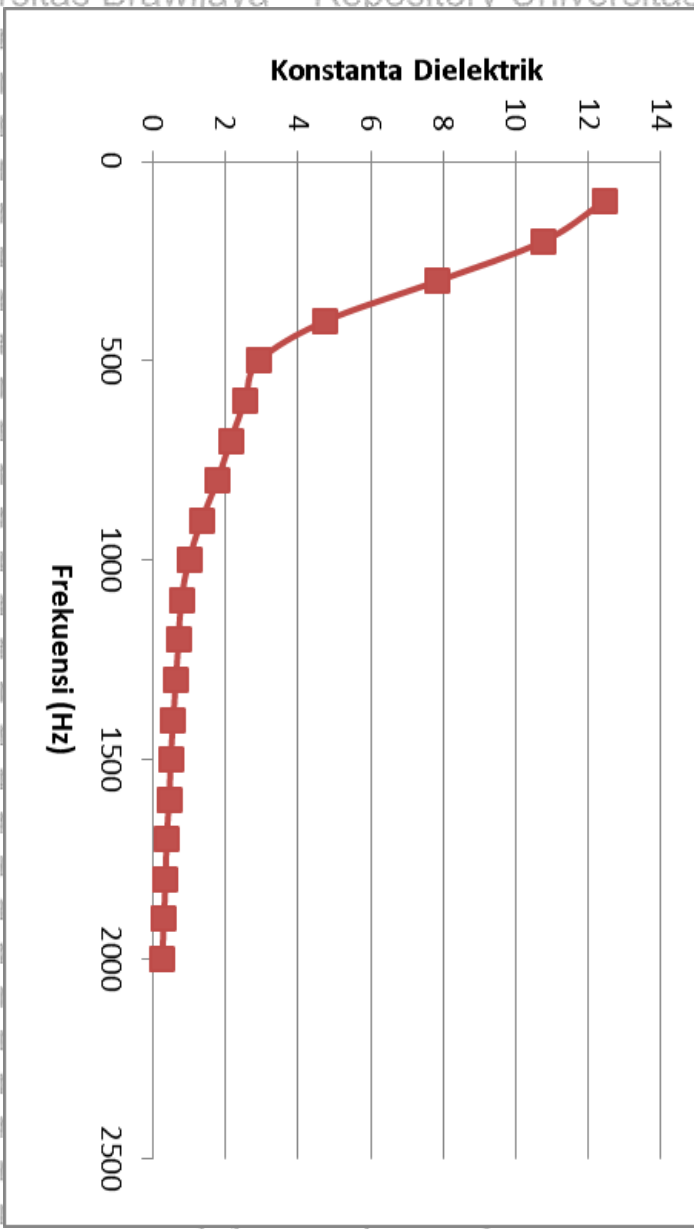

Gambar 4. 1 Grafik hubungan antara konstanta dielektrik udara dengan frekuensi.

Kalibrasi konstanta dielektrik udara bertujuan untuk mengetahui standarisasi plat kapasitor sejajar apakah sudah sesuai dengan literatur. Analisa data yang dilakukan yaitu untuk menggambarkan hubungan antara kapasitansi dan konstanta dielektrik terhadap perubahan frekuensi pengukuran. Nilai kapasitansi dan konstanta dielektrik yang diperoleh diplot terhadap frekuensi. Grafik dibuat trendline yang sesuai dan dianalisa trendline tersebut untuk mengetahui hubungan antara kapasitansi dan konstanta dielektrik terhadap perubahan frekuensi. Grafik diatas grafik hubungan antara konstanta dielektrik terhadap frekuensi. Pada grafik terlihat semakin besar nilai frekuensi yang diberikan membuat nilai konstanta dielektrik mengalami penurunan.

4.3 Konstanta Dielektrik

Penelitian ini bertujuan untuk mengetahui nilai kapasitansi dan konstanta dielektrik pada daging ayam yang direndam formalin, nilai konstanta dielektrik berbanding lurus dengan nilai kapasitansi. Nilai kapasitansi dipengaruhi oleh jarak pemisah antar plat, luas penampang plat kapasitor, selain itu kapasitansi juga dipengaruhi oleh sifat dan kondisi fisik bahan dielektrik yang diletakkan diantara plat. Nilai kapasitansi juga berubah seiring terjadinya perubahan frekuensi yang diberikan. Semakin besar frekuensi yang diberikan mengakibatkan lebih banyak gelombang yang ditransmisikan, sehingga muatan pada kapasitor tidak dapat terpenuhi karena arah arus sudah berbalik.

Banyaknya formalin yang digunakan untuk merendam daging ayam berpengaruh terhadap nilai kapasitansi daging ayam tersebut. Semakin banyak formalin yang diberikan tentunya membuat daging ayam semakin mengalami kerusakan. Semakin besar formalin yang diberikan, semakin besar juga formalin yang diserap oleh daging ayam.

4.3.1 Perendaman pada 0 mL formalin

Gambar 4.2 menampilkan perubahan nilai kapasitansi daging ayam yang tidak diberi formalin terhadap frekuensi antara 100 Hz - 2000 Hz dengan rentang 25 Hz. Nilai kapasitansi relatif mengalami penurunan. Nilai kapasitansi berbanding lurus dengan konstanta dielektrik, nilai kapasitansi relatif mengalami penurunan sehingga begitu juga dengan nilai konstanta dielektriknya mengalami penurunan.

Jaringan memiliki dualisme sifat karakteristik kelistrikan, suatu jaringan dapat bersifat sebagai konduktor atau dielektrik. Kebanyakan jaringan bersifat konduktor, elektrolit, sesuai dengan kelistrikan lapisan ganda yang sensitif terhadap komposisi permukaan apabila pada range frekuensi kurang dari 100 Hz. Sifat kapasitif yang penting dapat muncul pada frekuensi rendah 10 Hz. Sifat dielektrik dari jaringan mungkin akan lebih menyerupai sifat dari air, air murni memiliki karakteristik frekuensi relaksasi sekitar 18 GHz, hal ini terjadi pada frekuensi yang lebih tinggi 50 KHz. Konstanta dielektrik dipengaruhi oleh waktu relaksasi. Waktu relaksasi disebabkan oleh jeda waktu yang diperlukan oleh molekul bahan sampai terkutub (polarized) ketika mengalami perubahan medan listrik bahan disekitar bahan dielektriknya. Dalam sistem fisis, relaksasi dielektrik mengacu pada waktu respons relaksasi bahan dielektrik atas medan listrik luar. Relaksasi ini sering diterangkan dalam permitivitas sebagai fungsi terhadap frekuensi (Martinsen 2008). Dari grafik 4.2 didapatkan nilai persamaan garis regresinya sebagai berikut,

Tabel 4. 1 Tabel persamaan garis pada grafik hubungan frekuensi dan konstanta dielektrik pada perendaman formalin 0 mL

No	Sampel	Persamaan garis (Y)	R ²
1	A	$Y = 1E + 0,6 e^{-7E-04X}$	0,8735
2	B	$Y = 911180 e^{-1E-03X}$	0,8965
3	C	$Y = 7555506 e^{-0,001X}$	0,8997
4	D	$Y = 579757 e^{-0,001X}$	0,842

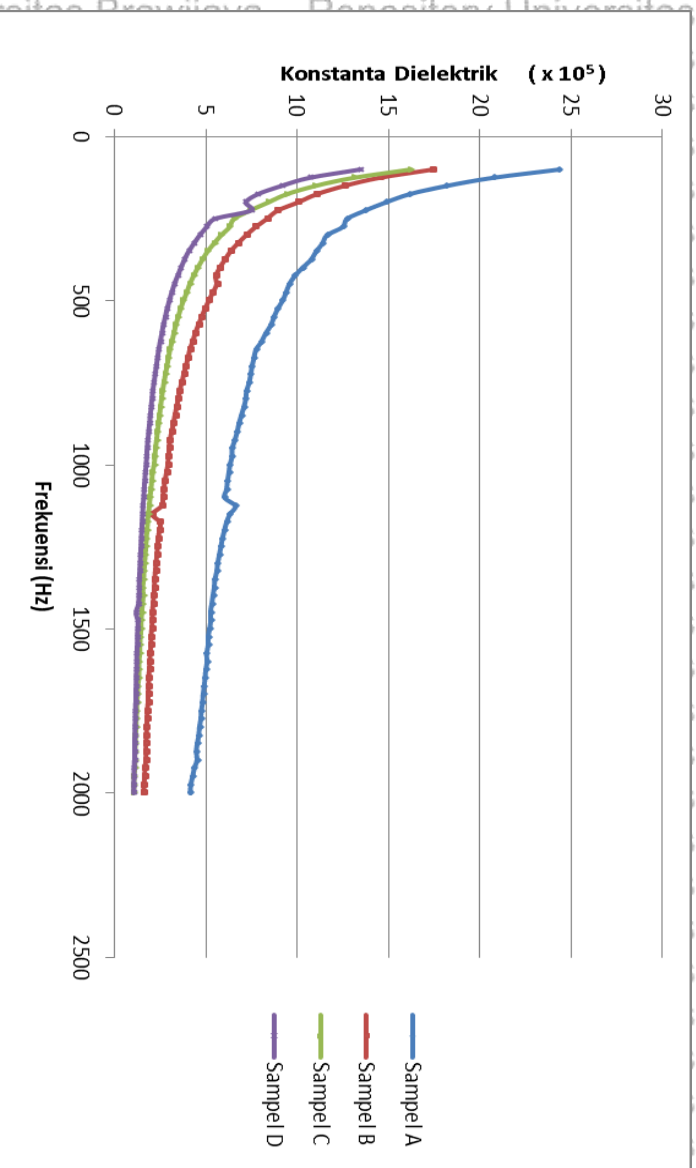

Gambar 4. 2 Gambar 4.2 Gambar grafik hubungan antara konstanta dielektrik daging ayam tanpa formalin (0 mL) terhadap penambahan frekuensi.

4.3.2 Perendaman pada 10 mL formalin

Pada daging yang bermassa 3 gr di rendam 10 mL formalin, terlihat beda secara fisik dengan daging yang tidak direndam formalin warna daging sedikit lebih pucat. Pengukuran nilai konstanta dielektrik daging ayam yang yang direndam formalin 10 mL dilakukan dengan mengukur nilai kapasitansi pada frekuensi 100 Hz sampai 2000 Hz dengan rentang pengukuran 25 Hz. Hasil dari pengukuran kapasitansi selanjutnya dihitung dengan menggunakan persamaan sehingga dihasilkan nilai konstanta dielektrik daging ayam yang direndam formalin 10 mL. Dari gambar 4.3 dapat terlihat hasilnya, didapatkan hasil bahwa konstanta dielektrik daging ayam yang direndam formalin 10 mL nilainya menurun seiring dengan bertambahnya nilai frekuensi yang diberikan. Hal ini karena nilai konstanta dielektrik berbanding lurus dengan nilai kapasitansi. Hal lainnya, diakibatkan oleh moment dipol yang berubah kesearahannya yang diakibatkan oleh frekuensi yang semakin tinggi. Konstanta dielektrik suatu bahan dipengaruhi oleh komposisi bahan. Bahan atau sempel pada penelitian ini diukur 5 kali pengukurann, dan dalam satu perlakuan terdapat 4 sampel. Dari grafik 4.3 didapatkan nilai persamaan garis regresinya sebagai berikut.

Tabel 4. 2 Tabel persamaan garis pada grafik hubungan frekuensi dan konstanta dielektrik pada perendaman formalin 10 mL.

No	Sampel	Persamaan garis (Y)	R ²
1	A	$Y = 724981 e^{-9E-04X}$	0,855
2	B	$Y = 492964 e^{-9E-04x}$	0,7617
3	C	$Y = 463948 e^{-9E-04X}$	0,8876
4	D	$Y = 520744 e^{-0,0001X}$	0,9622

Sampel A diukur pada jam ke 1, sampel B diukur pada jam ke 2, sampel C diukur jam ke 3, dan sampel D diukur jam ke 4, setiap perlakuan terdapat 4 sampel. Dilakukan perendaman selama 1 jam agar formalin meresap ke dalam daging, hal ini dilakukan pada semua perlakuan kecuali pada kontrol (0 mL) hanya didiamkan selama 1 jam. Pada penelitian ini perlu untuk mengetahui nilai batas maksimum daging ayam menyerap formalin, dan didapat pada penelitian sebelumnya ternyata ambang batas formalin adalah 30 mL, jadi pada pemberian dosis 30 mL membuat daging mengalami kerusakan. Tentunya kerusakan lebih banyak dari pada perendaman 10 mL.

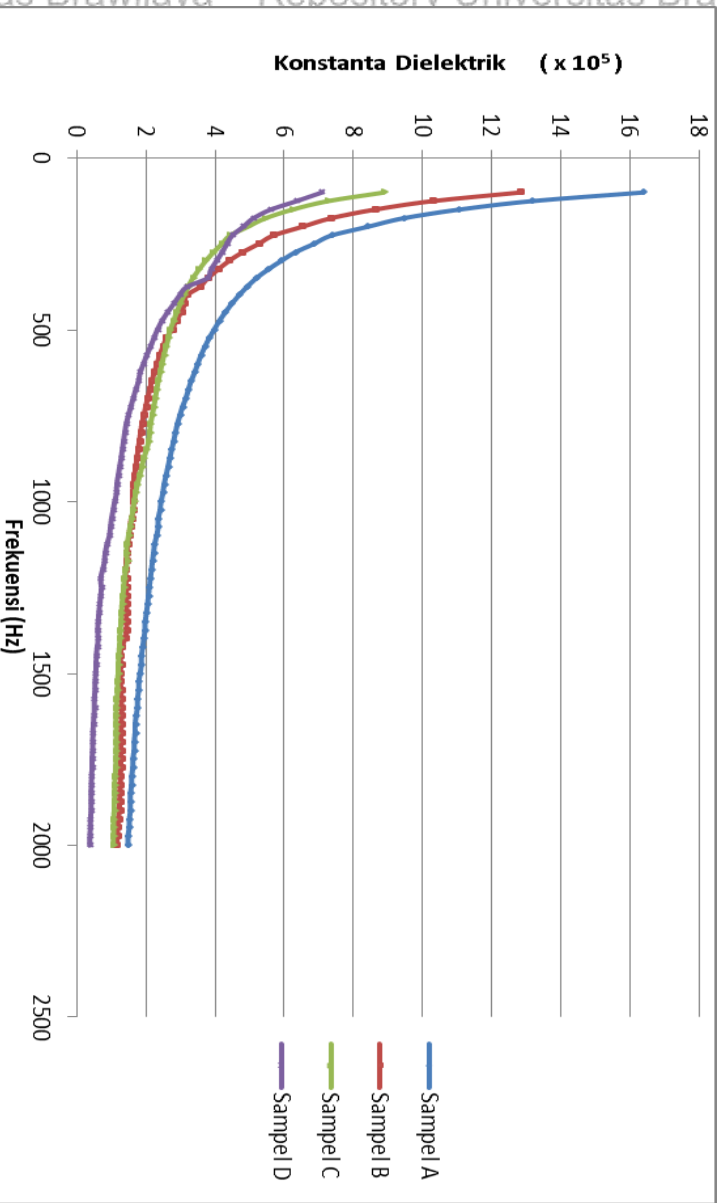

Gambar 4.3 Grafik hubungan antara konstanta dielektrik daging ayam yang direndam formalin 10 mL terhadap penambahan frekuensi.

4.3.3 Perendaman pada 20 mL formalin

Daging yang direndam 20 mL formalin, daging sudah mulai mengalami kerusakan pada protein walaupun tidak sebesar kerusakan pada daging yang direndam 30 mL formalin tpi kerusakannya lebih besar dari pada daging yang direndam 10 mL formalin. Pada gambar grafik, gambar 4.4 diketahui bahwa seiring dengan bertambahnya frekuensi yang diberikan, maka dapat mengakibatkan nilai konstanta dielektrik daging ayam yang direndam formalin 20 mL semakin menurun. Hal ini terjadi karena konstanta dielektrik suatu bahan tergantung pada nilai kapasitansi bahan tersebut. Semakin besar nilai kapasitansi suatu bahan maka semakin besar pula nilai konstanta dielektrik bahan tersebut. Karena kapasitansi berbanding lurus dengan nilai konstanta dielektrik. Dari tabel di atas dapat dinyatakan bahwa nilai kapasitansi relatif turun terhadap lamanya pengukuran. Terlihat nilai sampel A sampai Sampel D mengalami penurunan. Sampel A diukur pada jam ke 1, sampel B pada jam ke 2, sampel C pada jam ke 3, dan pada D jam ke 4. Hal ini juga terlihat pada pemberian perlakuan yang lain. Untuk pengukuran, pada LCR terdapat 4 mode yaitu mode C/D, C/R, L/Q dan R/Q. Dari grafik 4.4 didapatkan nilai persamaan garis regresinya sebagai berikut,

Tabel 4. 3 Tabel persamaan garis pada grafik hubungan frekuensi dan konstanta dielektrik pada daging yang direndam formalin 20 mL.

No	Sampel	Persamaan garis (Y)	R ²
1	A	$Y = 915878 e^{-7E-04X}$	0,9057
2	B	$Y = 702755 e^{-9E-04X}$	0,8848
3	C	$Y = 811489 e^{-0,001X}$	0,9239
4	D	$Y = 655432 e^{-0,001X}$	0,935

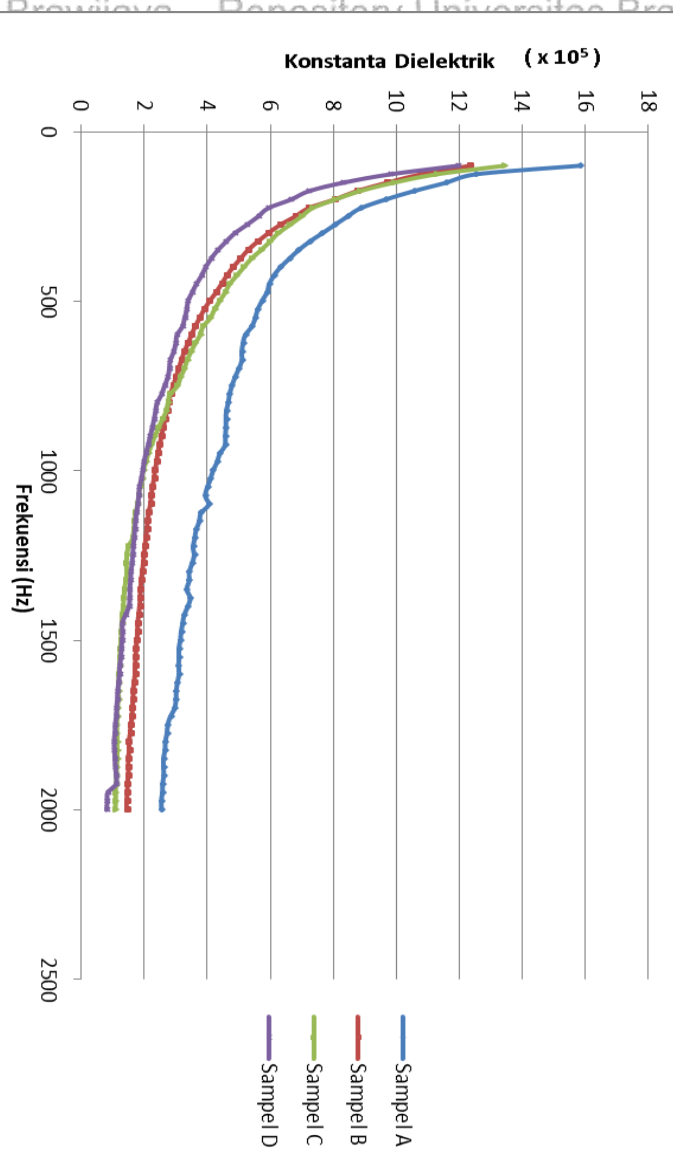

Gambar 4. 4 Gambar 4.4 Grafik hubungan antara konstanta dielektrik daging ayam yang direndam formalin 20 mL terhadap penambahan frekuensi.

4.3.4 Perendaman pada 30 mL formalin

Dosis 30 mL formalin dapat menyebabkan kematian pada manusia, seseorang mungkin hanya mampu bertahan 48 jam setelah mengonsumsi formalin dalam dosis fatal. Keracunan formalin menyebabkan radang, iritasi lambung, muntah, diare bercampur darah, kencing bercampur darah, dan gagalnya peredaran darah. Pada daging yang direndam formalin 30 mL daging kemungkinan mengalami kerusakan sehingga mempengaruhi nilai kapasitansi dan menyebabkan nilai konstanta dielektriknya mengalami penurunan. Nilai kapasitansi yang besar terdapat pada daging ayam kontrol (0 mL formalin) dan yang paling kecil nilai kapasitansinya pada daging yang direndam 30 mL formalin. Dosis 30 mL adalah batas maksimum penggunaan formalin.

Pengukuran nilai konstanta dielektrik daging ayam yang direndam formalin 30 mL dilakukan dengan mengukur nilai kapasitansi pada frekuensi 100 Hz sampai 2000 Hz dengan rentang pengukuran 25 Hz. Hasil dari pengukuran kapasitansi selanjutnya dihitung dengan menggunakan persamaan sehingga dihasilkan nilai konstanta dielektrik daging ayam yang direndam formalin 30 mL. Dari gambar 4.5 dapat terlihat hasilnya, didapatkan hasil bahwa konstanta dielektrik daging ayam yang direndam formalin 30 mL nilainya menurun seiring dengan bertambahnya nilai frekuensi yang diberikan. Hal ini karena nilai konstanta dielektrik berbanding lurus dengan nilai kapasitansi sesuai dengan persamaan. Hal lainnya, diakibatkan oleh moment dipol yang berubah kesearahannya yang diakibatkan oleh frekuensi yang semakin tinggi. Konstanta dielektrik suatu bahan dipengaruhi oleh komposisi bahan. Dari grafik 4.5 didapatkan nilai persamaan garis regresinya sebagai berikut,

Tabel 4. 4 Tabel persamaan garis pada grafik hubungan frekuensi dan konstanta dielektrik pada daging yang direndam formalin 30 mL

No	Sampel	Persamaan garis (Y)	R ²
1	A	$Y = 327514 e^{-1E-03X}$	0,9
2	B	$Y = 238578 e^{-9E-04X}$	0,8269
3	C	$Y = 284669 e^{-0,001X}$	0,8572
4	D	$Y = 25171 e^{-0,001X}$	0,843

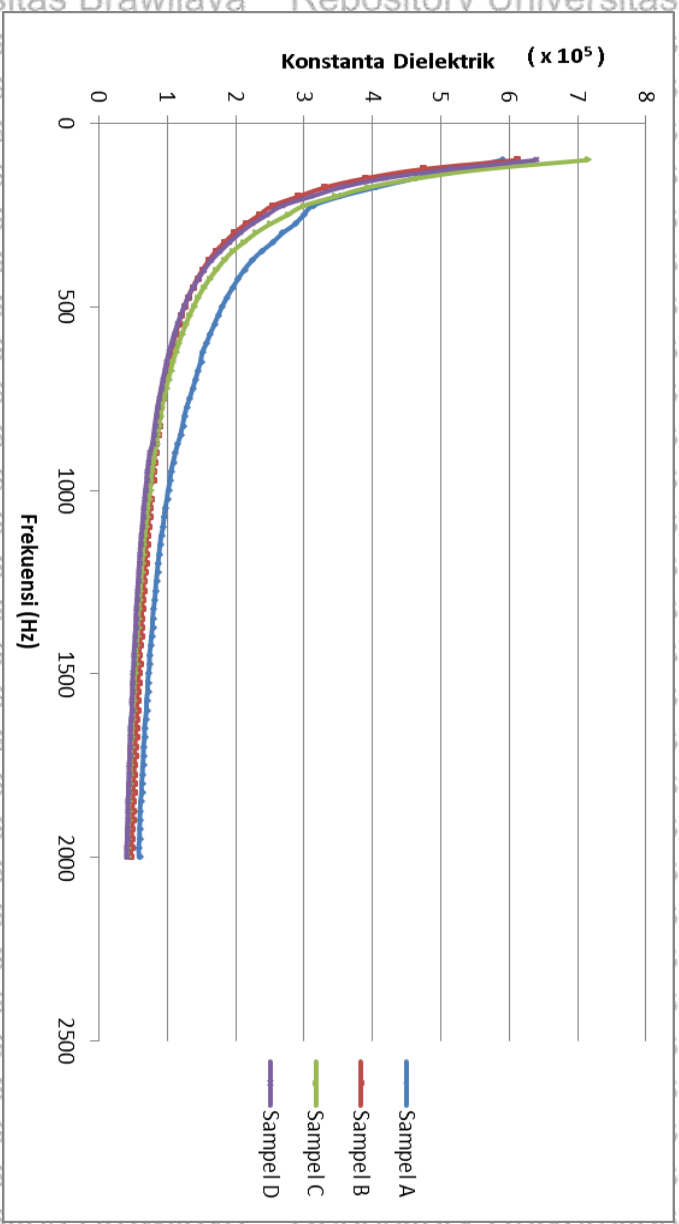

Gambar 4.5 Grafik hubungan antara konstanta dielektrik daging ayam. yang direndam formalin 30 mL terhadap penambahan frekuensi

4.3.5 Perendaman pada 40 mL formalin

Pada gambar grafik, gambar 4.6 diketahui bahwa seiring dengan bertambahnya frekuensi yang diberikan, maka dapat mengakibatkan nilai konstanta dielektrik daging ayam yang direndam formalin 40 mL semakin menurun. Hal ini terjadi karena konstanta dielektrik suatu bahan tergantung pada nilai kapasitansi bahan tersebut. Semakin besar nilai kapasitansi suatu bahan maka semakin besar pula nilai konstanta dielektrik bahan tersebut. Karena kapasitansi berbanding lurus dengan nilai konstanta dielektrik. Frekuensi yang digunakan dari 100 Hz sampai 2000 Hz dengan rentang frekuensi pengukuran 25 Hz. Batas maksimum penggunaan formalin adalah 30 mL jadi pada perendaman 40 mL ini daging kemungkinan mengalami denaturasi protein, kandungan protein makin sedikit yang ada kandungan airnya lebih banyak. Sehingga menyebabkan nilai kapasitansi pada daging yang direndam 40 mL hampir sama atau mengalami kenaikan sedikit dari pada daging ayam yang direndam formalin 30 mL. Dari grafik 4.6 didapatkan nilai persamaan garis regresinya sebagai berikut,

Tabel 4.5 Tabel persamaan garis pada grafik hubungan frekuensi dan konstanta dielektrik pada perendaman formalin 40 mL.

No	Sampel	Persamaan garis (Y)	R ²
1	A	$Y = 514855 e^{-0,001X}$	0,8563
2	B	$Y = 636268 e^{-0,002X}$	0,9545
3	C	$Y = 321296 e^{-8E-04X}$	0,7965
4	D	$Y = 416186 e^{-1E-03X}$	0,9189

Gambar 4.6 Grafik hubungan antara konstanta dielektrik daging ayam yang direndam formalin 40 mL terhadap penambahan frekuensi

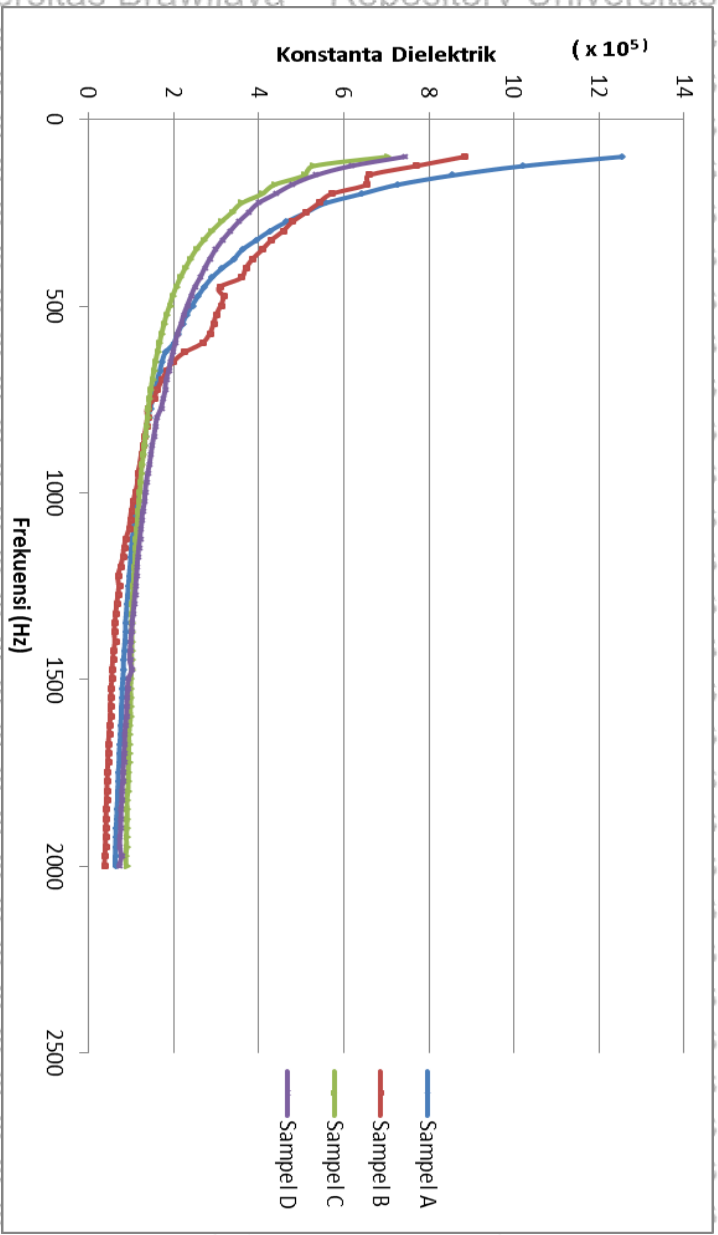

4.3.6 Perendaman pada 50 mL formalin

Pengukuran nilai konstanta dielektrik daging ayam yang direndam formalin 50 mL dilakukan dengan mengukur nilai kapasitansi pada frekuensi 100 Hz sampai 2000 Hz dengan rentang pengukuran 25 Hz. Hasil dari pengukuran kapasitansi selanjutnya dihitung dengan menggunakan persamaan sehingga dihasilkan nilai konstanta dielektrik daging ayam yang direndam formalin 50 mL. Dari gambar 4.7 dapat terlihat hasilnya, didapatkan hasil bahwa konstanta dielektrik daging ayam yang direndam formalin 50 mL nilainya menurun seiring dengan bertambahnya nilai frekuensi yang diberikan. Hal ini karena nilai konstanta dielektrik berbanding lurus dengan nilai kapasitansi sesuai dengan persamaan. Hal lainnya, diakibatkan oleh moment dipol yang berubah kesearahannya yang diakibatkan oleh frekuensi yang semakin tinggi. Konstanta dielektrik suatu bahan dipengaruhi oleh komposisi bahan. Dari grafik 4.7 didapatkan nilai persamaan garis regresinya sebagai berikut,

Tabel 4. 6 Tabel persamaan garis pada grafik hubungan frekuensi dan konstanta dielektrik pada perendaman formalin 50 mL.

No	Sampel	Persamaan garis (Y)	R ²
1	A	$Y = 555552 e^{-0,001X}$	0,8681
2	B	$Y = 1E + 06 e^{-8E-04X}$	0,8869
3	C	$Y = 414287 e^{-0,001X}$	0,8895
4	D	$Y = 485468 e^{-0,001X}$	0,9594

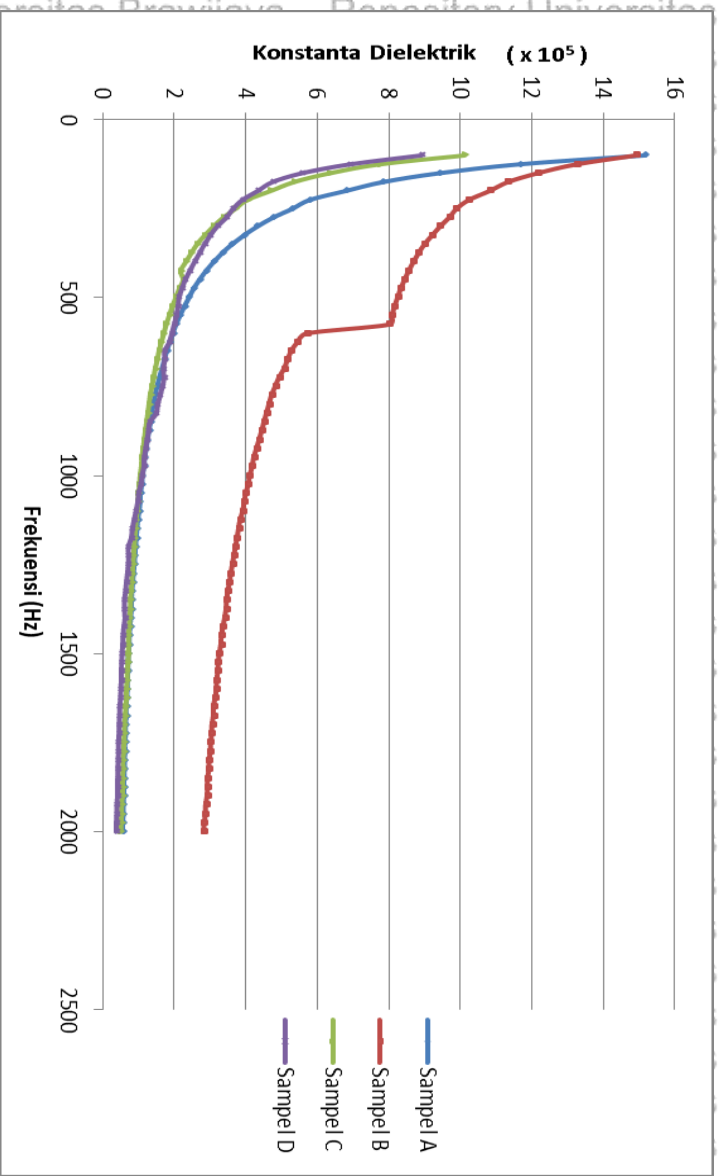

Gambar 4. 7 Grafik hubungan antara konstanta dielektrik daging ayam yang direndam formalin 50 mL terhadap penambahan frekuensi.

4.3.7 Perendaman daging ayam pada formalin

Daging ayam yang telah mengalami perlakuan berbeda dapat mempengaruhi nilai kapasitansinya karena memiliki kondisi fisik yang berbeda pula. Bahan dielektrik ketika diberikan medan akan menghasilkan medan listrik luar, dan menyebabkan polarisasi. Proses polarisasi momen dipol listrik bergantung pada kuat medan listrik luar. Semakin besar medan listrik luar dapat mengakibatkan dipol listrik terus bergerak, sehingga proses penyearahan dipol tidak stabil. Kenaikan dan penurunan kapasitansi yang terjadi ketika pengukuran disebabkan proses penyearah dipol listrik pada bahan dielektrik belum stabil.

Kapasitansi selain dipengaruhi oleh luas penampang dan jarak antar plat, kapasitansi juga dipengaruhi oleh sifat dan kondisi bahan dielektrik yang terdapat diantara plat. Nilai kapasitansi akan berubah apabila terjadi perubahan frekuensi pengukuran. Semakin besar nilai frekuensi yang diberikan dapat mengakibatkan lebih banyak gelombang yang di transmisikan. Kapasitor yang seharusnya terisi penuh dengan muatan, tidak dapat terpenuhi dikarenakan arah arus sudah berbalik. Dari grafik 4.8 diatas didapatkan persamaan garis regresinya sebagai berikut,

Tabel 4. 7 Tabel persamaan garis pada grafik hubungan frekuensi dan konstanta dielektrik.

No	Sampel	Persamaan garis (Y)	R ²
1	0 mL	$Y = 903232 e^{-9E-04X}$	0,8747
2	10 mL	$Y = 764707 e^{-9E-04X}$	0,9152
3	20 mL	$Y = 541668 e^{-1E-03X}$	0,8705
4	30 mL	$Y = 275921 e^{-0,001X}$	0,8598
5	40 mL	$Y = 459422 e^{-0,001X}$	0,8931
6	50 mL	$Y = 624650 e^{-0,001X}$	0,922

Kadungan gizi yang cukup tinggi merupakan media yang ideal bagi pertumbuhan mikroorganismе. Daging ayam mengalami rusak atau pembusukan apabila setelah pemotongan tidak segera dilakukan penyimpanan yang tepat. Maka pada penelitian ini daging yang sudah diukur lalu ditempatkan di dalam plastik klip dan dimasukkan di dalam toples kecil hal ini bertujuan untuk meminimalisir pertumbuhan mikroorganismе yang dapat membuat daging ayam mengalami kerusakan atau pembusukan karena mikroorganismе.

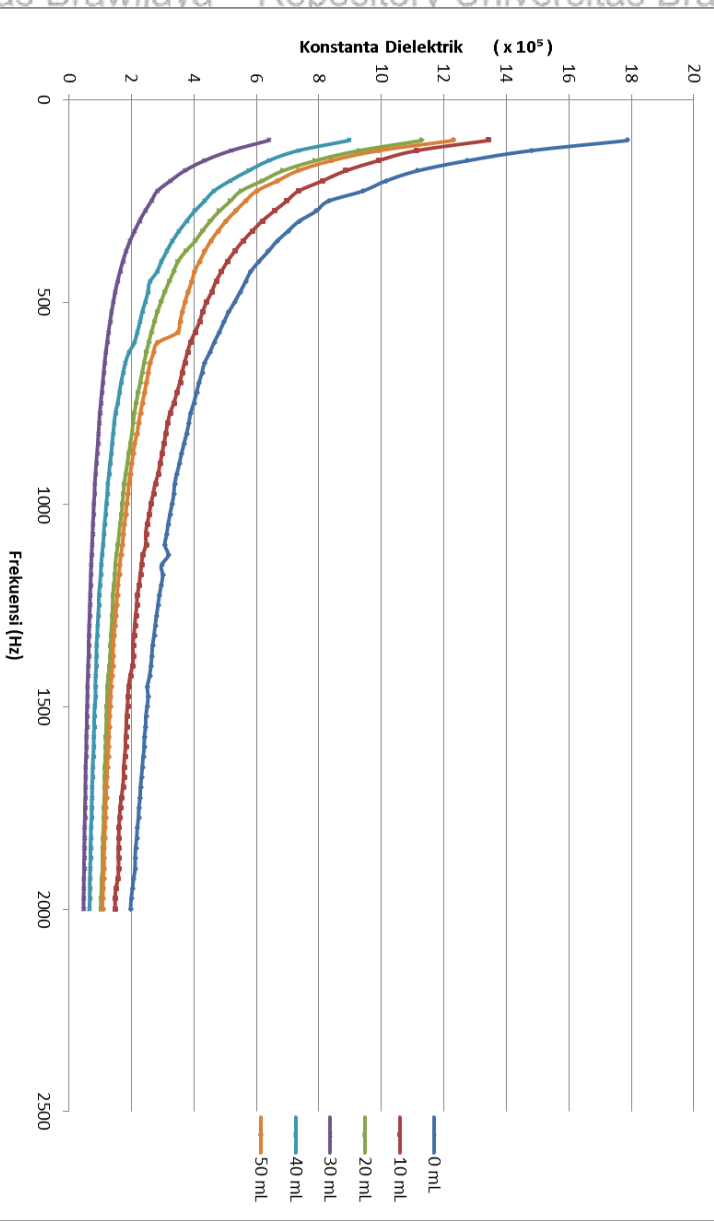

Gambar 4. 8 Grafik hubungan antara frekuensi dengan konstanta dielektrik daging ayam pada rendaman formalin.

4.4 Faktor Faktor yang Mempengaruhi Nilai Konstanta Dielektrik

Kenaikan kapasitansi disebabkan oleh melemahnya medan listrik diantara keping kapasitor akibat kehadiran dielektrik. Dengan demikian, untuk jumlah muatan tertentu pada keping kapasitor perbedaan potensial menjadi lebih kecil dan rasio Q/V bertambah besar. Nilai konstanta dielektrik berbanding lurus dengan nilai kapasitansi, apabila nilai kapasitansi naik maka nilai konstanta dielektrik juga naik. Nilai kapasitansi tergantung pada luas penampang plat kapasitor, jarak antar plat, semakin besar nilai luas penampang maka semakin besar juga nilai kapasitansinya, dan apabila jarak antar plat semakin besar maka nilai kapasitansinya semakin kecil. Jadi nilai konstanta dielektrik sangat dipengaruhi oleh nilai kapasitansi, luas penampang dan jarak antar plat. Selain hal tersebut bahan dielektrik juga sangat mempengaruhi nilai konstanta dielektrik.

Dielektrik dapat memperlemah medan listrik antara keping keping suatu kapasitor karena dengan hadirnya medan listrik molekul-molekul dalam dielektrik akan menghasilkan medan listrik tambahan yang arahnya berlawanan dengan medan listrik luar. Jika molekul-molekul dalam dielektrik bersifat polar, dielektrik tersebut memiliki momen dipol permanen. Momen dipol secara normal tersebar acak, dalam pengaruh medan listrik diantara keping-keping kapasitor, momen dipol menerima suatu gaya torka yang memaksa momen dipol untuk menyetarakan diri dengan arah medan listrik. Kemampuan momen dipol untuk menyetarakan diri dengan medan listrik bergantung pada kuat medan dan temperatur. Pada temperatur tinggi, gerak termal molekul- molekul yang bersifat acak, cenderung menghambat proses penyetaraan. Jika molekul-molekul dielektrik bersifat non polar, maka dalam pengaruh suatu medan listrik luar, molekul-molekul dielektrik akan menginduksi momen-momen dipol yang searah dengan medan listrik dikatakan terpolarisasi oleh medan, tidak peduli polarisasi tersebut disebabkan oleh penyetarakan momen-momen dipol permanen dari suatu molekul-molekul polar atau akibat terjadinya momen-momen dipol induksi dalam molekul-molekul non

polar. Dipol-dipol molekular menghasilkan suatu medan listrik tambahan yang arahnya berlawanan dengan medan awal, sehingga dapat melemahkan medan awal.

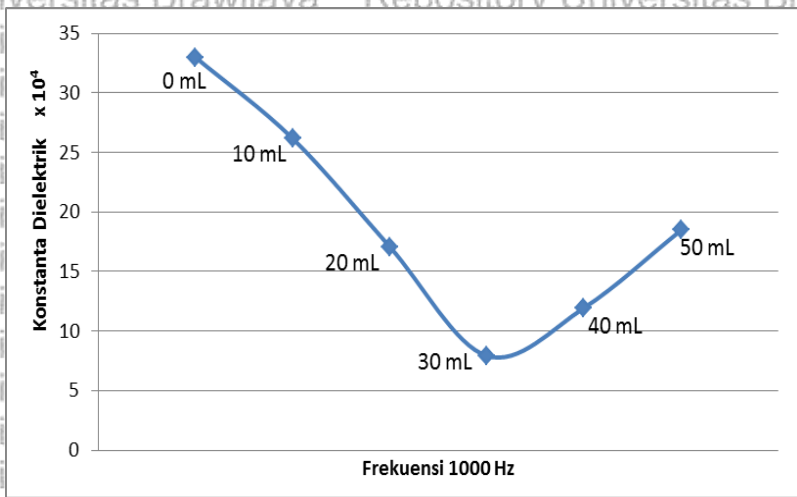

Gambar 4. 9 Grafik konstanta dielektrik pada frekuensi sama (1000 Hz) dengan penambahan formalin

Dari grafik di atas dapat diketahui bahwa nilai konstanta dielektrik pada perendaman 0 mL sampai 30 mL mengalami penurunan dan mengalami kenaikan pada perendaman 30 mL sampai 50 mL. Hal ini terjadi dikarenakan batas dosis pemberian formalin adalah 30 mL, sehingga pada dosis tersebut daging mengalami kerusakan pada protein (denaturasi protein). Jadi pada daging yang direndam pada 40 mL dan 50 mL formalin hanya kandungan air yang terdeteksi pada alat LCR meter karena protein pada daging tersebut rusak, sehingga menyebabkan nilai kapasitansi mengalami kenaikan.

BAB V

PENUTUP

5.1 Kesimpulan

Perlakuan dengan menambahkan formalin pada daging ayam mempengaruhi nilai kapasitansi dan konstanta dielektrik,

1. Nilai kapasitansi mengalami penurunan pada daging yang direndam formalin 0 mL sampai 30 mL, dan mengalami kenaikan pada daging yang direndam formalin 30 mL sampai 50 mL. Nilai kapasitansi terbesar pada daging yang direndam 0 mL formalin dan nilai tertrendah pada daging yang direndam 30 mL formalin.
2. Didapatkan nilai kapasitansi berkisar antar $8,62 \times 10^{-7}$ F sampai $1,47 \times 10^{-7}$ F dan nilai konstanta dielektrik berkisar antar $24,36 \times 10^4$ sampai $41,69 \times 10^4$ pada daging yang direndam 0 mL formalin. Pada daging yang direndam 10 mL nilai kapasitansi antara $5,79 \times 10^{-7}$ F sampai $5,26 \times 10^{-8}$ F dan nilai konstanta dielektrik berkisar antar $16,37 \times 10^4$ sampai $14,88 \times 10^4$. Pada daging yang direndam 30 mL nilai kapasitansi antara $2,08 \times 10^{-7}$ F sampai $2,08 \times 10^{-8}$ F dan nilai konstanta dielektrik berkisar antar $58,89 \times 10^4$ sampai $58,98 \times 10^3$. Didapatkan nilai Kr sekitar 0,4.

5.2 Saran

Penelitian selanjutnya untuk lebih memperhatikan variasi waktu lama perendaman daging ayam di dalam formalin sehingga dapat digunakan untuk mengetahui kerusakan daging ayam akibat lamanya perendaman pada formalin. Selain itu juga dilakukan lebih banyak variasi pemberian formalin.

DAFTAR PUSTAKA

- Dwiatmaja, Anggara Wahyu. 2013. *Rancang Bangun Sistem Deteksi Daging Ayam Tiren Berbasis Resistansi Dan Mikrokontroler Atmega8*.
- Frenske, K. & D. Mirsa. 2000. *Dielectric Materials at Microwave Frequencies*. Appl. Microw. Wireless.
- Giancoli, Douglas C. 2001. *Fisika Jilid 2 Edisi Kelima*. [diterjemahkan Dra. Yuhliza Hanum, M. Eng]. Jakarta: Erlangga.
- Gulita, Natalia Diyaning. 2015. *Identifikasi Sifat Dielektrik Pisang Pada Tingkat Kematangan Berbeda Dengan Rangkaian RLC*. Radiasi-Pendidikan Fisika 6.
- Halliday & Resnick. 2000. *Fisika Jilid 2 Edisi Ketiga*. Jakarta: Erlangga.
- Hermawan, B. 2005. *Monitoring Kadar Air Tanah Melalui Pengukuran Sifat Dielektrik Pada Lahan Jagung*. Jurnal Ilmu-Ilmu Pertanian Indonesia
- Kato, K. 1997. *Electrical Density Sorting and Estimation of Soluble Solids Content of Watermelon*. J.Agric. Engng. Res.
- Martinsen,O.G.,2000. *Non-Invasive Measurements Of Post-Morten Changes In Dielectric Properties Of Haddock Muscle- A Pilot Study*. Journal Of Food Engineering
- Martinsen,O.G dan Sverie, C. 2008. *Bioimpedance and Bioelectricity Basics, Second Edition*. London: Academic Press Elsevier.

Windholz, 1989. *The Merck Index an Encyclopedia of Chemicals, Drug And Biologicals*. Eleventh Edition. Usc. Merck And Co, Inc.

Young & Freedman, 2003. *Fisika Universitas Edisi Kesepuluh Jilid 2*. Jakarta : Erlangga.

LAMPIRAN

Lampiran 1. 1 Gambar cara kalibrasi LCR Meter

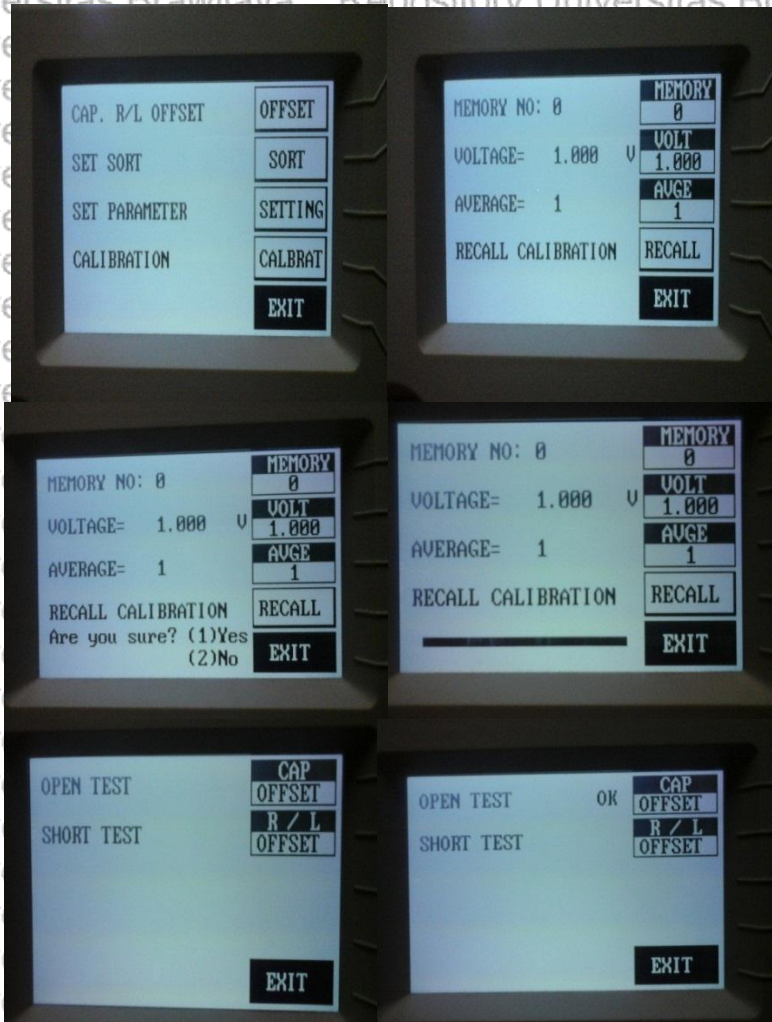

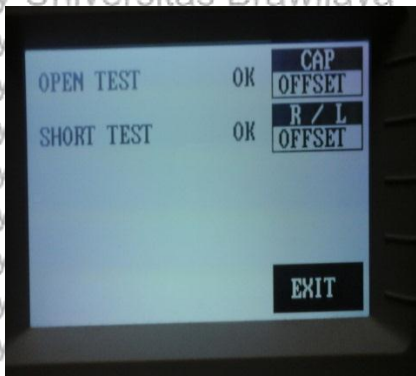

Lampiran 1. 2 Alat Dan Bahan





Lampiran 1. 3 Data penelitian

a. 0 mL

1. Sampel A

No	F (Hz)	F (kHz)	C1 (F)	C2 (F)	C3 (F)	C4 (F)	C5 (F)	C rata-rata (F)	ϵ	Kr
1	100	0.1	8.55E-07	8.604E-07	8.612E-07	8.6654E-07	8.687E-07	8.6246E-07	2436327.7	0.4985
2	125	0.125	7.35E-07	7.334E-07	7.3693E-07	7.3635E-07	7.323E-07	7.34862E-07	2075881.4	0.43349
3	150	0.15	6.44E-07	6.434E-07	6.4465E-07	6.4426E-07	6.449E-07	6.44184E-07	1819728.8	0.41899
4	175	0.17647	5.71E-07	5.728E-07	5.7429E-07	5.7302E-07	5.721E-07	5.7265E-07	1617655.4	0.42674
5	200	0.2	5.24E-07	5.267E-07	5.263E-07	5.2753E-07	5.281E-07	5.26552E-07	1487495	0.43553
6	225	0.23077	4.88E-07	4.873E-07	4.8624E-07	4.8546E-07	4.846E-07	4.8624E-07	1373559.3	0.43174
7	250	0.25	4.52E-07	4.521E-07	4.5159E-07	4.5147E-07	4.512E-07	4.51622E-07	1275768.4	0.41778
8	275	0.27523	4.44E-07	4.435E-07	4.4254E-07	4.4051E-07	4.438E-07	4.42942E-07	1251248.6	0.44365
9	300	0.3	4.13E-07	4.139E-07	4.1083E-07	4.1038E-07	4.154E-07	4.12732E-07	1165909.6	0.47513
10	325	0.32433	4.03E-07	4.041E-07	4.0313E-07	4.0364E-07	4.05E-07	4.03786E-07	1140638.4	0.42555
11	350	0.35088	3.91E-07	3.913E-07	3.9104E-07	3.9121E-07	3.909E-07	3.91138E-07	1104909.6	0.41714
12	375	0.375	3.82E-07	3.811E-07	3.8084E-07	3.8193E-07	3.822E-07	3.81526E-07	107757.1	0.4219
13	400	0.4	3.66E-07	3.64E-07	3.6348E-07	3.6363E-07	3.645E-07	3.64422E-07	102940.7	0.44264
14	425	0.42553	3.5E-07	3.505E-07	3.5057E-07	3.4806E-07	3.487E-07	3.49632E-07	987661.02	0.44233
15	450	0.45113	3.39E-07	3.394E-07	3.3855E-07	3.3904E-07	3.393E-07	3.39082E-07	957858.76	0.41883
16	475	0.47619	3.32E-07	3.332E-07	3.3278E-07	3.3326E-07	3.339E-07	3.33124E-07	941028.25	0.42289
17	500	0.5	3.26E-07	3.258E-07	3.2588E-07	3.2706E-07	3.268E-07	3.26242E-07	921587.57	0.42517
18	525	0.52632	3.17E-07	3.168E-07	3.1694E-07	3.1634E-07	3.162E-07	3.1672E-07	894689.27	0.42215
19	550	0.55046	3.09E-07	3.096E-07	3.0946E-07	3.0994E-07	3.099E-07	3.09644E-07	874700.56	0.41836
20	575	0.57693	3.04E-07	3.039E-07	3.0473E-07	3.0262E-07	3.023E-07	3.03532E-07	857435.03	0.44393
21	600	0.6	2.94E-07	2.936E-07	2.9307E-07	2.9282E-07	2.926E-07	2.93194E-07	828231.64	0.42534
22	625	0.625	2.85E-07	2.854E-07	2.853E-07	2.8533E-07	2.854E-07	2.85372E-07	806135.59	0.41676
23	650	0.65218	2.74E-07	2.739E-07	2.7432E-07	2.749E-07	2.753E-07	2.74454E-07	775293.79	0.42928
24	675	0.67416	2.71E-07	2.707E-07	2.7059E-07	2.7088E-07	2.71E-07	2.70832E-07	765062.15	0.41759
25	700	0.69768	2.67E-07	2.673E-07	2.6659E-07	2.6669E-07	2.672E-07	2.66976E-07	754169.49	0.41995
26	725	0.7229	2.65E-07	2.649E-07	2.6498E-07	2.6432E-07	2.636E-07	2.6457E-07	747372.88	0.42955
27	750	0.75	2.61E-07	2.613E-07	2.6139E-07	2.616E-07	2.619E-07	2.61452E-07	738564.97	0.41957
28	775	0.77923	2.56E-07	2.563E-07	2.5646E-07	2.5643E-07	2.567E-07	2.5638E-07	724237.29	0.4184
29	800	0.80001	2.55E-07	2.55E-07	2.5506E-07	2.5508E-07	2.549E-07	2.55034E-07	720435.03	0.41694
30	825	0.82192	2.51E-07	2.512E-07	2.5143E-07	2.5101E-07	2.51E-07	2.51074E-07	709248.59	0.41977
31	850	0.84508	2.46E-07	2.466E-07	2.4618E-07	2.4592E-07	2.463E-07	2.46294E-07	695745.76	0.41953
32	875	0.86957	2.42E-07	2.416E-07	2.4152E-07	2.4162E-07	2.415E-07	2.41562E-07	682378.53	0.41677
33	900	0.89553	2.38E-07	2.384E-07	2.3837E-07	2.3852E-07	2.385E-07	2.38434E-07	673542.37	0.417
34	925	0.92308	2.34E-07	2.337E-07	2.3358E-07	2.3393E-07	2.339E-07	2.33798E-07	660446.33	0.41768
35	950	0.95239	2.29E-07	2.283E-07	2.2844E-07	2.2847E-07	2.286E-07	2.28534E-07	645576.27	0.41926
36	975	0.96775	2.28E-07	2.283E-07	2.2863E-07	2.285E-07	2.282E-07	2.28404E-07	645209.04	0.41816
37	1000	1	2.24E-07	2.243E-07	2.2442E-07	2.2434E-07	2.242E-07	2.24316E-07	633661.02	0.41695
38	1025	1.017	2.22E-07	2.223E-07	2.2225E-07	2.2192E-07	2.221E-07	2.22116E-07	627446.33	0.41774
39	1050	1.0526	2.2E-07	2.196E-07	2.1971E-07	2.1947E-07	2.195E-07	2.19574E-07	620265.54	0.4172
40	1075	1.0714	2.18E-07	2.179E-07	2.1773E-07	2.1767E-07	2.176E-07	2.17794E-07	615237.29	0.4181
41	1100	1.0909	2.14E-07	2.141E-07	2.1414E-07	2.141E-07	2.142E-07	2.14152E-07	604949.15	0.41702
42	1125	1.1321	2.36E-07	2.354E-07	2.3483E-07	2.3427E-07	2.339E-07	2.34786E-07	663237.29	0.43955
43	1150	1.1539	2.25E-07	2.244E-07	2.2428E-07	2.243E-07	2.236E-07	2.24232E-07	633423.73	0.42254
44	1175	1.1765	2.18E-07	2.179E-07	2.1778E-07	2.1769E-07	2.176E-07	2.1774E-07	615084.75	0.41744
45	1200	1.2	2.14E-07	2.137E-07	2.1364E-07	2.1351E-07	2.136E-07	2.13578E-07	603327.68	0.41691
46	1225	1.2245	2.1E-07	2.097E-07	2.0938E-07	2.0925E-07	2.093E-07	2.09426E-07	591598.87	0.41838
47	1250	1.25	2.07E-07	2.068E-07	2.0687E-07	2.0678E-07	2.067E-07	2.06762E-07	584073.45	0.41716
48	1275	1.2766	2.04E-07	2.037E-07	2.0364E-07	2.0348E-07	2.033E-07	2.03576E-07	575073.45	0.41829
49	1300	1.3044	2E-07	2.006E-07	2.0052E-07	2.0059E-07	2.005E-07	2.00508E-07	566406.78	0.41696
50	1325	1.3333	1.99E-07	1.987E-07	1.9866E-07	1.9871E-07	1.987E-07	1.98696E-07	561288.14	0.41669

51	1350	1.3636	1.95E-07	1.951E-07	1.9497E-07	1.9486E-07	1.948E-07	1.94958E-07	550728.81	0.41771
52	1375	1.3636	1.94E-07	1.939E-07	1.9367E-07	1.9353E-07	1.934E-07	1.93698E-07	547169.49	0.42128
53	1400	1.3954	1.91E-07	1.912E-07	1.9113E-07	1.9119E-07	1.911E-07	1.91162E-07	540005.65	0.41696
54	1425	1.4286	1.89E-07	1.89E-07	1.8888E-07	1.8883E-07	1.889E-07	1.88908E-07	533638.42	0.41697
55	1450	1.4634	1.86E-07	1.862E-07	1.8629E-07	1.865E-07	1.866E-07	1.8637E-07	526468.93	0.41853
56	1475	1.4634	1.87E-07	1.871E-07	1.8696E-07	1.8724E-07	1.872E-07	1.87096E-07	528519.77	0.4177
57	1500	1.5	1.85E-07	1.847E-07	1.8474E-07	1.8475E-07	1.849E-07	1.8473E-07	521836.16	0.41713
58	1525	1.5385	1.82E-07	1.818E-07	1.8187E-07	1.8178E-07	1.817E-07	1.81812E-07	513593.22	0.41708
59	1550	1.5385	1.82E-07	1.819E-07	1.8194E-07	1.8213E-07	1.821E-07	1.81992E-07	514101.69	0.41778
60	1575	1.579	1.79E-07	1.79E-07	1.7906E-07	1.7907E-07	1.79E-07	1.79012E-07	505683.62	0.41697
61	1600	1.579	1.79E-07	1.797E-07	1.7997E-07	1.8034E-07	1.807E-07	1.79996E-07	508463.28	0.43593
62	1625	1.6216	1.77E-07	1.773E-07	1.7734E-07	1.7743E-07	1.775E-07	1.77338E-07	500954.8	0.41789
63	1650	1.6667	1.76E-07	1.759E-07	1.7589E-07	1.7589E-07	1.759E-07	1.7589E-07	496779.66	0.41682
64	1675	1.6667	1.75E-07	1.748E-07	1.7489E-07	1.7428E-07	1.736E-07	1.74452E-07	492802.26	0.4387
65	1700	1.7143	1.72E-07	1.723E-07	1.7227E-07	1.7223E-07	1.721E-07	1.72248E-07	486576.27	0.41734
66	1725	1.7143	1.71E-07	1.711E-07	1.7119E-07	1.7118E-07	1.712E-07	1.71122E-07	483395.48	0.41736
67	1750	1.7647	1.69E-07	1.688E-07	1.6876E-07	1.6869E-07	1.688E-07	1.68784E-07	476790.96	0.4172
68	1775	1.7647	1.68E-07	1.676E-07	1.6781E-07	1.6776E-07	1.679E-07	1.67722E-07	473790.96	0.4179
69	1800	1.8182	1.65E-07	1.65E-07	1.6502E-07	1.6507E-07	1.651E-07	1.65012E-07	466135.59	0.41696
70	1825	1.8182	1.64E-07	1.639E-07	1.6388E-07	1.6404E-07	1.642E-07	1.63958E-07	463158.19	0.41898
71	1850	1.875	1.61E-07	1.607E-07	1.6073E-07	1.6077E-07	1.608E-07	1.6076E-07	454124.29	0.41681
72	1875	1.875	1.59E-07	1.59E-07	1.5941E-07	1.5942E-07	1.595E-07	1.5942E-07	449836.16	0.42317
73	1900	1.875	1.6E-07	1.605E-07	1.6046E-07	1.6035E-07	1.602E-07	1.6038E-07	453050.85	0.41785
74	1925	1.9355	1.55E-07	1.55E-07	1.5502E-07	1.5511E-07	1.552E-07	1.55112E-07	438169.49	0.41783
75	1950	1.9355	1.52E-07	1.521E-07	1.5199E-07	1.5195E-07	1.519E-07	1.52016E-07	429423.73	0.41798
76	1975	2	1.48E-07	1.483E-07	1.4831E-07	1.4829E-07	1.482E-07	1.48292E-07	418903.95	0.41723
77	2000	2	1.48E-07	1.476E-07	1.4748E-07	1.4747E-07	1.477E-07	1.47598E-07	416943.5	0.41817

2. Sampel B

No	F (Hz)	F (kHz)	C1 (F)	C2 (F)	C3 (F)	C4 (F)	C5 (F)	C rata-rata (F)	ϵ	Kr
1	100	0.1	6.15E-07	6.16E-07	6.1735E-07	6.1857E-07	6.189E-07	6.17212E-07	1743536.7	0.49279
2	125	0.125	5.16E-07	5.149E-07	5.1419E-07	5.1386E-07	5.138E-07	5.1453E-07	1453474.6	0.42389
3	150	0.15	4.45E-07	4.475E-07	4.4665E-07	4.4561E-07	4.451E-07	4.46034E-07	1259983.1	0.4287
4	175	0.17647	3.91E-07	3.914E-07	3.9456E-07	3.9504E-07	3.918E-07	3.92836E-07	1109706.2	0.46467
5	200	0.2	3.57E-07	3.563E-07	3.5669E-07	3.5592E-07	3.553E-07	3.56146E-07	1006062.1	0.42314
6	225	0.23077	3.17E-07	3.171E-07	3.1716E-07	3.1673E-07	3.163E-07	3.16864E-07	895096.05	0.41958
7	250	0.25	2.96E-07	2.961E-07	2.9592E-07	2.962E-07	2.968E-07	2.96248E-07	836858.76	0.41976
8	275	0.27523	2.75E-07	2.74E-07	2.7396E-07	2.7405E-07	2.743E-07	2.74184E-07	774531.07	0.41898
9	300	0.3	2.56E-07	2.557E-07	2.5564E-07	2.5556E-07	2.556E-07	2.55692E-07	722293.79	0.41728
10	325	0.32433	2.4E-07	2.396E-07	2.3988E-07	2.3956E-07	2.394E-07	2.39592E-07	676813.56	0.41805
11	350	0.35088	2.25E-07	2.247E-07	2.2449E-07	2.2506E-07	2.256E-07	2.25014E-07	635632.77	0.42619
12	375	0.375	2.14E-07	2.144E-07	2.1472E-07	2.147E-07	2.146E-07	2.14546E-07	606062.15	0.4188
13	400	0.4	2.05E-07	2.042E-07	2.0434E-07	2.0399E-07	2.045E-07	2.04324E-07	577186.44	0.42035
14	425	0.42553	1.97E-07	1.967E-07	1.9686E-07	1.9682E-07	1.975E-07	1.96934E-07	556395.48	0.42278
15	450	0.45113	1.98E-07	1.983E-07	1.9834E-07	1.9842E-07	1.986E-07	1.98374E-07	560378.53	0.41773
16	475	0.47619	1.9E-07	1.907E-07	1.9165E-07	1.9148E-07	1.913E-07	1.91064E-07	539728.81	0.44003
17	500	0.5	1.83E-07	1.829E-07	1.837E-07	1.8303E-07	1.827E-07	1.83138E-07	517338.98	0.42704
18	525	0.52632	1.75E-07	1.758E-07	1.7572E-07	1.7591E-07	1.76E-07	1.75768E-07	496519.77	0.42077
19	550	0.55046	1.69E-07	1.69E-07	1.6948E-07	1.6959E-07	1.692E-07	1.69296E-07	478237.29	0.42113
20	575	0.57693	1.63E-07	1.63E-07	1.6278E-07	1.6247E-07	1.627E-07	1.62842E-07	460005.65	0.42531
21	600	0.6	1.57E-07	1.566E-07	1.5646E-07	1.5666E-07	1.569E-07	1.5675E-07	442796.61	0.42416
22	625	0.625	1.52E-07	1.517E-07	1.52E-07	1.5208E-07	1.52E-07	1.5192E-07	429152.54	0.41901
23	650	0.65218	1.47E-07	1.47E-07	1.46E-07	1.4564E-07	1.459E-07	1.46326E-07	413350.28	0.46307
24	675	0.67416	1.44E-07	1.435E-07	1.4288E-07	1.4276E-07	1.425E-07	1.43064E-07	404135.59	0.44776
25	700	0.69768	1.39E-07	1.385E-07	1.3877E-07	1.388E-07	1.38E-07	1.3853E-07	391327.68	0.42903

26	725	0.7229	1.35E-07	1.348E-07	1.3473E-07	1.3461E-07	1.345E-07	1.34644E-07	380350.28	0.41789
27	750	0.75	1.3E-07	1.307E-07	1.3092E-07	1.3108E-07	1.314E-07	1.30878E-07	369711.86	0.43762
28	775	0.77923	1.26E-07	1.264E-07	1.2672E-07	1.2684E-07	1.27E-07	1.26588E-07	357593.22	0.43833
29	800	0.80001	1.24E-07	1.243E-07	1.2385E-07	1.2365E-07	1.241E-07	1.24042E-07	350401.13	0.42966
30	825	0.82192	1.21E-07	1.208E-07	1.2078E-07	1.2084E-07	1.209E-07	1.2089E-07	341497.18	0.41889
31	850	0.84508	1.18E-07	1.178E-07	1.1739E-07	1.1742E-07	1.175E-07	1.17548E-07	332056.5	0.42102
32	875	0.86957	1.14E-07	1.144E-07	1.1461E-07	1.1458E-07	1.145E-07	1.14494E-07	323429.38	0.41843
33	900	0.89553	1.12E-07	1.116E-07	1.1151E-07	1.1106E-07	1.11E-07	1.1136E-07	314576.27	0.43231
34	925	0.92308	1.08E-07	1.081E-07	1.0801E-07	1.0771E-07	1.077E-07	1.0794E-07	304915.25	0.42769
35	950	0.95239	1.07E-07	1.067E-07	1.0675E-07	1.0655E-07	1.065E-07	1.06608E-07	301152.54	0.41842
36	975	0.96775	1.05E-07	1.053E-07	1.0535E-07	1.0545E-07	1.045E-07	1.05186E-07	297135.59	0.44508
37	1000	1	1.04E-07	1.038E-07	1.0374E-07	1.0396E-07	1.038E-07	1.03886E-07	293463.28	0.42067
38	1025	1.017	1.01E-07	1.015E-07	1.0133E-07	1.0107E-07	1.01E-07	1.01222E-07	285937.85	0.42659
39	1050	1.0526	9.79E-08	9.791E-08	9.7797E-08	9.7857E-08	9.798E-08	9.78858E-08	276513.56	0.41784
40	1075	1.0714	9.64E-08	9.607E-08	9.6118E-08	9.6117E-08	9.594E-08	9.61316E-08	271558.19	0.42445
41	1100	1.0909	9.41E-08	9.4E-08	9.3957E-08	9.3876E-08	9.384E-08	9.3946E-08	265384.18	0.41875
42	1125	1.1321	9.18E-08	9.189E-08	9.1972E-08	9.2211E-08	9.201E-08	9.19678E-08	259796.05	0.42444
43	1150	1.1539	9E-08	1.003E-08	9.0045E-08	9.0035E-08	9.001E-08	9.40264E-08	209114.12	21.6184
44	1175	1.1765	8.9E-08	8.908E-08	8.8915E-08	8.8878E-08	8.901E-08	8.89702E-08	251328.25	0.41861
45	1200	1.2	8.76E-08	8.727E-08	8.7673E-08	8.7595E-08	8.752E-08	8.75208E-08	247233.9	0.42398
46	1225	1.2245	8.54E-08	8.54E-08	8.5351E-08	8.5384E-08	8.541E-08	8.53924E-08	241221.47	0.4169
47	1250	1.25	8.41E-08	8.411E-08	8.4095E-08	8.4083E-08	8.404E-08	8.40914E-08	237515.43	0.41707
48	1275	1.2766	8.26E-08	8.267E-08	8.2609E-08	8.2628E-08	8.268E-08	8.2646E-08	233463.28	0.41695
49	1300	1.3044	8.14E-08	8.13E-08	8.1306E-08	8.1261E-08	8.12E-08	8.1285E-08	229618.64	0.41806
50	1325	1.3333	7.96E-08	7.962E-08	7.9605E-08	7.9548E-08	7.947E-08	7.95766E-08	224792.66	0.41857
51	1350	1.3636	7.85E-08	7.846E-08	7.8411E-08	7.8389E-08	7.837E-08	7.84166E-08	221515.82	0.4173
52	1375	1.3636	7.8E-08	7.793E-08	7.7927E-08	7.7923E-08	7.791E-08	7.79306E-08	220142.94	0.41689
53	1400	1.3954	7.66E-08	7.66E-08	7.6597E-08	7.6592E-08	7.661E-08	7.66014E-08	216388.14	0.41669
54	1425	1.4286	7.52E-08	7.52E-08	7.5198E-08	7.5181E-08	7.519E-08	7.5194E-08	212412.43	0.4167
55	1450	1.4634	7.39E-08	7.392E-08	7.4019E-08	7.4054E-08	7.403E-08	7.3993E-08	209019.77	0.41811
56	1475	1.4634	7.36E-08	7.361E-08	7.3615E-08	7.3691E-08	7.38E-08	7.3664E-08	208090.4	0.41972
57	1500	1.5	7.26E-08	7.254E-08	7.2534E-08	7.2566E-08	7.271E-08	7.25818E-08	205033.33	0.41917
58	1525	1.5385	7.13E-08	7.127E-08	7.1224E-08	7.1307E-08	7.129E-08	7.12722E-08	201333.9	0.41713
59	1550	1.5385	7.12E-08	7.119E-08	7.1227E-08	7.1292E-08	7.129E-08	7.12328E-08	201222.6	0.41824
60	1575	1.579	6.98E-08	6.979E-08	6.9718E-08	6.9567E-08	6.95E-08	6.9683E-08	196844.63	0.42731
61	1600	1.579	6.94E-08	6.943E-08	6.942E-08	6.9389E-08	6.938E-08	6.9408E-08	196067.8	0.41689
62	1625	1.6216	6.81E-08	6.806E-08	6.8053E-08	6.807E-08	6.813E-08	6.80778E-08	192310.17	0.41713
63	1650	1.6667	6.66E-08	6.663E-08	6.6619E-08	6.6903E-08	6.685E-08	6.67638E-08	188598.31	0.42559
64	1675	1.6667	6.66E-08	6.661E-08	6.6601E-08	6.6605E-08	6.66E-08	6.66072E-08	188155.93	0.41669
65	1700	1.7143	6.55E-08	6.546E-08	6.5406E-08	6.5417E-08	6.542E-08	6.54308E-08	184832.77	0.41699
66	1725	1.7143	6.55E-08	6.546E-08	6.5478E-08	6.5542E-08	6.554E-08	6.55038E-08	185038.98	0.4174
67	1750	1.7647	6.4E-08	6.388E-08	6.3977E-08	6.4065E-08	6.399E-08	6.3977E-08	180725.99	0.41996
68	1775	1.7647	6.42E-08	6.413E-08	6.4017E-08	6.4054E-08	6.402E-08	6.40862E-08	181034.46	0.42067
69	1800	1.8182	6.25E-08	6.254E-08	6.2491E-08	6.2495E-08	6.249E-08	6.25102E-08	176582.97	0.417
70	1825	1.8182	6.25E-08	6.241E-08	6.2379E-08	6.2358E-08	6.234E-08	6.23882E-08	176237.85	0.41799
71	1850	1.875	6.11E-08	6.123E-08	6.1292E-08	6.1301E-08	6.116E-08	6.12132E-08	172918.64	0.42207
72	1875	1.875	6.11E-08	6.118E-08	6.1206E-08	6.1282E-08	6.123E-08	6.12032E-08	172890.4	0.41888
73	1900	1.875	6.13E-08	6.124E-08	6.1228E-08	6.1234E-08	6.111E-08	6.12142E-08	172921.47	0.41899
74	1925	1.9355	5.99E-08	5.982E-08	5.9817E-08	5.9716E-08	5.968E-08	5.97948E-08	168911.3	0.4233
75	1950	1.9355	5.89E-08	5.895E-08	5.8936E-08	5.8935E-08	5.893E-08	5.89408E-08	166499.44	0.41672
76	1975	2	5.79E-08	5.787E-08	5.7665E-08	5.755E-08	5.766E-08	5.77234E-08	163600.45	0.43074
77	2000	2	5.68E-08	5.69E-08	5.6988E-08	5.6776E-08	5.676E-08	5.68402E-08	160565.54	0.4239

3. Sampel C

No	F (Hz)	F (kHz)	C1 (F)	C2 (F)	C3 (F)	C4 (F)	C5 (F)	Crata-rata (F)	ε	Kr
1	100	0.1	5.75E-07	5.746E-07	5.7402E-07	5.7346E-07	5.733E-07	5.74172E-07	1621954.8	0.42238
2	125	0.125	4.66E-07	4.655E-07	4.649E-07	4.6424E-07	4.64E-07	4.64932E-07	1313367.2	0.42444
3	150	0.15	3.91E-07	3.904E-07	3.898E-07	3.8965E-07	3.895E-07	3.90024E-07	1101762.7	0.42174
4	175	0.17647	3.35E-07	3.347E-07	3.3468E-07	3.3453E-07	3.345E-07	3.34594E-07	945180.79	0.4169
5	200	0.2	2.99E-07	2.988E-07	2.9871E-07	2.9851E-07	2.982E-07	2.98616E-07	843548.02	0.41848
6	225	0.23077	2.63E-07	2.634E-07	2.6331E-07	2.6337E-07	2.632E-07	2.63354E-07	743937.85	0.41695
7	250	0.25	2.44E-07	2.443E-07	2.442E-07	2.4417E-07	2.442E-07	2.4425E-07	656073.45	0.415877
8	275	0.27523	2.24E-07	2.239E-07	2.2381E-07	2.237E-07	2.236E-07	2.23802E-07	632209.04	0.41796
9	300	0.3	2.07E-07	2.074E-07	2.0731E-07	2.0733E-07	2.074E-07	2.0737E-07	585790.96	0.41686
10	325	0.32433	1.94E-07	1.936E-07	1.9357E-07	1.936E-07	1.934E-07	1.93564E-07	546790.96	0.41714
11	350	0.35088	1.81E-07	1.808E-07	1.8065E-07	1.8056E-07	1.805E-07	1.80654E-07	510322.03	0.41766
12	375	0.375	1.71E-07	1.707E-07	1.7065E-07	1.7062E-07	1.706E-07	1.70658E-07	482084.75	0.417
13	400	0.4	1.62E-07	1.617E-07	1.6169E-07	1.6163E-07	1.616E-07	1.61674E-07	456706.21	0.41703
14	425	0.42553	1.54E-07	1.535E-07	1.5343E-07	1.5338E-07	1.534E-07	1.53438E-07	433440.68	0.41722
15	450	0.45113	1.46E-07	1.461E-07	1.4611E-07	1.4608E-07	1.461E-07	1.46114E-07	412751.41	0.41678
16	475	0.47619	1.41E-07	1.406E-07	1.4065E-07	1.4055E-07	1.406E-07	1.4057E-07	397090.4	0.41692
17	500	0.5	1.34E-07	1.341E-07	1.341E-07	1.3406E-07	1.34E-07	1.34098E-07	378807.91	0.41729
18	525	0.52632	1.29E-07	1.285E-07	1.2841E-07	1.2837E-07	1.284E-07	1.28442E-07	362830.51	0.41755
19	550	0.55046	1.24E-07	1.238E-07	1.2373E-07	1.237E-07	1.237E-07	1.23728E-07	349514.12	0.41698
20	575	0.57693	1.19E-07	1.192E-07	1.1917E-07	1.1913E-07	1.191E-07	1.19168E-07	336632.77	0.41698
21	600	0.6	1.16E-07	1.155E-07	1.1546E-07	1.1545E-07	1.154E-07	1.15468E-07	326180.79	0.41685
22	625	0.625	1.12E-07	1.118E-07	1.1173E-07	1.1163E-07	1.117E-07	1.11748E-07	315672.32	0.41918
23	650	0.65218	1.08E-07	1.079E-07	1.0784E-07	1.0778E-07	1.078E-07	1.07832E-07	304610.17	0.41763
24	675	0.67416	1.05E-07	1.049E-07	1.0492E-07	1.0495E-07	1.05E-07	1.04916E-07	296372.88	0.41695
25	700	0.69768	1.02E-07	1.022E-07	1.0215E-07	1.0211E-07	1.021E-07	1.02148E-07	288553.67	0.4172
26	725	0.7229	9.93E-08	9.925E-08	9.9222E-08	9.9199E-08	9.917E-08	9.92216E-08	280287.01	0.417
27	750	0.75	9.64E-08	9.64E-08	9.6368E-08	9.6349E-08	9.636E-08	9.63828E-08	272676.8	0.41704
28	775	0.77923	9.36E-08	9.37E-08	9.3712E-08	9.3713E-08	9.365E-08	9.367E-08	264604.52	0.41772
29	800	0.80001	9.16E-08	9.158E-08	9.1554E-08	9.1555E-08	9.157E-08	9.15728E-08	258680.23	0.41679
30	825	0.82192	8.98E-08	8.977E-08	8.9771E-08	8.9777E-08	8.978E-08	8.97744E-08	253600	0.41668
31	850	0.84508	8.79E-08	8.793E-08	8.7915E-08	8.7899E-08	8.796E-08	8.7927E-08	248381.36	0.41681
32	875	0.86957	8.59E-08	8.594E-08	8.5912E-08	8.5908E-08	8.589E-08	8.59178E-08	242705.65	0.41683
33	900	0.89553	8.39E-08	8.386E-08	8.3857E-08	8.3842E-08	8.388E-08	8.38636E-08	236902.82	0.41675
34	925	0.92308	8.21E-08	8.201E-08	8.2006E-08	8.2014E-08	8.201E-08	8.20196E-08	231693.79	0.41683
35	950	0.95239	8.0E-08	8.002E-08	8.0026E-08	8.0033E-08	8.007E-08	8.00386E-08	226097.74	0.41681
36	975	0.96775	7.91E-08	7.905E-08	7.9062E-08	7.9038E-08	7.903E-08	7.90462E-08	223294.35	0.41673
37	1000	1	7.72E-08	7.72E-08	7.718E-08	7.7189E-08	7.72E-08	7.7201E-08	218081.92	0.41684
38	1025	1.017	7.42E-08	7.419E-08	7.4177E-08	7.4167E-08	7.416E-08	7.41772E-08	209540.11	0.41678
39	1050	1.0526	7.3E-08	7.295E-08	7.2928E-08	7.2917E-08	7.291E-08	7.29324E-08	206023.73	0.41692
40	1075	1.0714	7.13E-08	7.126E-08	7.1218E-08	7.1193E-08	7.117E-08	7.12294E-08	201212.99	0.41815
41	1100	1.0909	6.95E-08	6.951E-08	6.9506E-08	6.9497E-08	6.949E-08	6.95054E-08	196342.94	0.41677
42	1125	1.1321	6.82E-08	6.821E-08	6.8206E-08	6.8196E-08	6.818E-08	6.82026E-08	192662.71	0.41677
43	1150	1.1539	6.61E-08	6.608E-08	6.6067E-08	6.6056E-08	6.604E-08	6.60668E-08	186629.38	0.41689
44	1175	1.1765	6.49E-08	6.486E-08	6.4843E-08	6.4838E-08	6.482E-08	6.48436E-08	183174.01	0.41677
45	1200	1.2	6.37E-08	6.368E-08	6.3677E-08	6.3667E-08	6.366E-08	6.36744E-08	179871.19	0.41674
46	1225	1.2245	6.25E-08	6.248E-08	6.2463E-08	6.2452E-08	6.245E-08	6.24696E-08	176467.8	0.41699
47	1250	1.25	6.13E-08	6.131E-08	6.1313E-08	6.1311E-08	6.13E-08	6.13114E-08	173196.05	0.41672
48	1275	1.2766	6.02E-08	6.017E-08	6.0158E-08	6.0151E-08	6.015E-08	6.01592E-08	169941.24	0.41675
49	1300	1.3044	5.9E-08	5.902E-08	5.9013E-08	5.901E-08	5.901E-08	5.90178E-08	166716.95	0.41678
50	1325	1.3333	5.79E-08	5.792E-08	5.7908E-08	5.7895E-08	5.789E-08	5.7908E-08	163581.92	0.41692

51	1350	1.3636	1.95E-07	1.951E-07	1.9497E-07	1.9486E-07	1.948E-07	1.94958E-07	550728.81	0.41771
52	1375	1.3636	1.94E-07	1.939E-07	1.9367E-07	1.9353E-07	1.934E-07	1.93698E-07	547169.49	0.42128
53	1400	1.3954	1.91E-07	1.912E-07	1.9113E-07	1.9119E-07	1.911E-07	1.91162E-07	540005.65	0.41696
54	1425	1.4286	1.89E-07	1.89E-07	1.8888E-07	1.8883E-07	1.889E-07	1.88908E-07	533638.42	0.41697
55	1450	1.4634	1.86E-07	1.862E-07	1.8629E-07	1.865E-07	1.866E-07	1.8637E-07	526468.93	0.41853
56	1475	1.4634	1.87E-07	1.871E-07	1.8696E-07	1.8724E-07	1.872E-07	1.87096E-07	528519.77	0.41777
57	1500	1.5	1.85E-07	1.847E-07	1.8474E-07	1.8475E-07	1.849E-07	1.8473E-07	521836.16	0.41713
58	1525	1.5385	1.82E-07	1.818E-07	1.8187E-07	1.8178E-07	1.817E-07	1.81812E-07	513593.22	0.41708
59	1550	1.5385	1.82E-07	1.819E-07	1.8194E-07	1.8213E-07	1.821E-07	1.81992E-07	514101.69	0.41778
60	1575	1.579	1.79E-07	1.79E-07	1.7906E-07	1.7907E-07	1.79E-07	1.79012E-07	505683.62	0.41697
61	1600	1.579	1.79E-07	1.797E-07	1.7997E-07	1.8034E-07	1.807E-07	1.79996E-07	508463.28	0.43593
62	1625	1.6216	1.77E-07	1.773E-07	1.7734E-07	1.7743E-07	1.775E-07	1.77338E-07	500954.8	0.41789
63	1650	1.6667	1.76E-07	1.759E-07	1.758E-07	1.7589E-07	1.759E-07	1.7586E-07	496779.66	0.41682
64	1675	1.6667	1.75E-07	1.748E-07	1.7489E-07	1.7428E-07	1.736E-07	1.74452E-07	492802.26	0.4387
65	1700	1.7143	1.72E-07	1.723E-07	1.7227E-07	1.7223E-07	1.721E-07	1.72248E-07	486576.27	0.41734
66	1725	1.7143	1.71E-07	1.711E-07	1.7119E-07	1.7118E-07	1.712E-07	1.71122E-07	483395.48	0.41736
67	1750	1.7647	1.69E-07	1.688E-07	1.6876E-07	1.6869E-07	1.688E-07	1.68784E-07	476790.96	0.4172
68	1775	1.7647	1.68E-07	1.676E-07	1.6781E-07	1.6776E-07	1.679E-07	1.67722E-07	473790.96	0.41719
69	1800	1.8182	1.65E-07	1.65E-07	1.6502E-07	1.6507E-07	1.651E-07	1.65012E-07	466135.59	0.41696
70	1825	1.8182	1.64E-07	1.639E-07	1.6388E-07	1.6404E-07	1.642E-07	1.63958E-07	463158.19	0.41898
71	1850	1.875	1.61E-07	1.607E-07	1.6073E-07	1.6077E-07	1.608E-07	1.6076E-07	454124.29	0.41681
72	1875	1.875	1.59E-07	1.59E-07	1.5941E-07	1.5942E-07	1.595E-07	1.59425E-07	449836.16	0.42317
73	1900	1.875	1.6E-07	1.605E-07	1.6046E-07	1.6035E-07	1.602E-07	1.6038E-07	453050.85	0.41785
74	1925	1.9355	1.55E-07	1.55E-07	1.5502E-07	1.5511E-07	1.552E-07	1.55112E-07	438169.49	0.41783
75	1950	1.9355	1.52E-07	1.521E-07	1.5199E-07	1.5195E-07	1.519E-07	1.52016E-07	429423.73	0.41798
76	1975	2	1.48E-07	1.483E-07	1.4831E-07	1.4829E-07	1.482E-07	1.48292E-07	418903.95	0.41723
77	2000	2	1.48E-07	1.476E-07	1.4748E-07	1.4747E-07	1.477E-07	1.47598E-07	416943.5	0.41817

4. Sampel D

No	F (Hz)	F (kHz)	C1 (F)	C2 (F)	C3 (F)	C4 (F)	C5 (F)	Cirata-rata (F)	ϵ	Kr
1	100	0.1	4.78E-07	4.771E-07	4.7618E-07	4.7501E-07	4.739E-07	4.76104E-07	1344926.6	0.44736
2	125	0.125	3.76E-07	3.913E-07	3.7675E-07	3.7655E-07	3.762E-07	3.79312E-07	1071502.8	0.89192
3	150	0.15	3.25E-07	3.24E-07	3.2407E-07	3.2375E-07	3.241E-07	3.24156E-07	915694.92	0.42121
4	175	0.17647	2.79E-07	2.786E-07	2.7867E-07	2.7855E-07	2.786E-07	2.78604E-07	787016.95	0.41676
5	200	0.2	2.52E-07	2.512E-07	2.5152E-07	2.5199E-07	2.628E-07	2.55096E-07	720610.17	0.9922
6	225	0.23077	2.62E-07	2.614E-07	2.6668E-07	2.664E-07	2.688E-07	2.64986E-07	748548.02	0.69693
7	250	0.25	1.96E-07	1.956E-07	1.9555E-07	1.9548E-07	1.954E-07	1.95538E-07	552367.23	0.41734
8	275	0.27523	1.79E-07	1.793E-07	1.7915E-07	1.7905E-07	1.79E-07	1.79158E-07	506096.05	0.41865
9	300	0.3	1.66E-07	1.658E-07	1.6576E-07	1.6573E-07	1.657E-07	1.6576E-07	468248.59	0.41683
10	325	0.32433	1.55E-07	1.545E-07	1.5448E-07	1.5446E-07	1.544E-07	1.54488E-07	436406.78	0.41689
11	350	0.35088	1.44E-07	1.44E-07	1.4402E-07	1.44E-07	1.44E-07	1.44016E-07	406824.86	0.41668
12	375	0.375	1.36E-07	1.36E-07	1.3595E-07	1.3593E-07	1.359E-07	1.35964E-07	384079.1	0.41687
13	400	0.4	1.29E-07	1.291E-07	1.291E-07	1.2912E-07	1.291E-07	1.29106E-07	364706.21	0.41669
14	425	0.42553	1.23E-07	1.226E-07	1.2262E-07	1.2258E-07	1.226E-07	1.22612E-07	346361.58	0.41687
15	450	0.45113	1.16E-07	1.165E-07	1.1649E-07	1.1644E-07	1.165E-07	1.16476E-07	329028.25	0.41682
16	475	0.47619	1.11E-07	1.1133E-07	1.1131E-07	1.1131E-07	1.113E-07	1.11318E-07	314545.67	0.41672
17	500	0.5	1.07E-07	1.07E-07	1.0697E-07	1.07E-07	1.07E-07	1.06978E-07	302197.74	0.41672
18	525	0.52632	1.03E-07	1.026E-07	1.0254E-07	1.0251E-07	1.025E-07	1.02534E-07	289644.07	0.41686
19	550	0.55046	9.89E-08	9.886E-08	9.8831E-08	9.8819E-08	9.88E-08	9.88376E-08	279202.26	0.41689
20	575	0.57693	9.51E-08	9.512E-08	9.5107E-08	9.5093E-08	9.509E-08	9.51054E-08	268659.32	0.41672
21	600	0.6	9.22E-08	9.221E-08	9.2195E-08	9.2179E-08	9.216E-08	9.21948E-08	260437.29	0.41685
22	625	0.625	8.92E-08	8.916E-08	8.9152E-08	8.9144E-08	8.914E-08	8.91542E-08	251848.02	0.41671
23	650	0.65218	8.62E-08	8.616E-08	8.6128E-08	8.6129E-08	8.611E-08	8.61398E-08	243332.77	0.41684
24	675	0.67416	8.39E-08	8.385E-08	8.3834E-08	8.3828E-08	8.382E-08	8.38398E-08	236835.59	0.41679
25	700	0.69768	8.16E-08	8.156E-08	8.1546E-08	8.155E-08	8.154E-08	8.15528E-08	230375.14	0.41671

26	725	0.7229	7.93E-08	7.928E-08	7.9275E-08	7.9266E-08	7.926E-08	7.92756E-08	223942.37	0.41673
27	750	0.75	7.71E-08	7.706E-08	7.7049E-08	7.7042E-08	7.704E-08	7.70516E-08	217659.89	0.41673
28	775	0.77923	7.47E-08	7.464E-08	7.4623E-08	7.4616E-08	7.461E-08	7.4628E-08	210813.56	0.41678
29	800	0.80001	7.3E-08	7.303E-08	7.3024E-08	7.3022E-08	7.302E-08	7.30248E-08	206284.75	0.41669
30	825	0.82192	7.15E-08	7.151E-08	7.1497E-08	7.1481E-08	7.147E-08	7.14938E-08	201959.89	0.41682
31	850	0.84508	7E-08	6.996E-08	6.9954E-08	6.9963E-08	6.996E-08	6.99558E-08	197615.25	0.41668
32	875	0.86957	6.83E-08	6.833E-08	6.832E-08	6.8314E-08	6.831E-08	6.83196E-08	192993.22	0.41672
33	900	0.89553	6.68E-08	6.682E-08	6.6812E-08	6.6814E-08	6.682E-08	6.68176E-08	188750.28	0.41668
34	925	0.92308	6.53E-08	6.525E-08	6.5244E-08	6.5239E-08	6.523E-08	6.52346E-08	184303.95	0.41671
35	950	0.95239	6.37E-08	6.373E-08	6.3719E-08	6.3709E-08	6.371E-08	6.37144E-08	179984.18	0.41671
36	975	0.96775	6.29E-08	6.293E-08	6.2928E-08	6.292E-08	6.291E-08	6.29254E-08	177755.37	0.41672
37	1000	1	6.19E-08	6.182E-08	6.1738E-08	6.1676E-08	6.163E-08	6.17604E-08	174464.41	0.42573
38	1025	1.017	6.05E-08	6.054E-08	6.0533E-08	6.0529E-08	6.052E-08	6.05334E-08	170998.31	0.41672
39	1050	1.0526	5.9E-08	5.895E-08	5.8942E-08	5.8928E-08	5.892E-08	5.89404E-08	166498.31	0.41691
40	1075	1.0714	5.81E-08	5.811E-08	5.8096E-08	5.8095E-08	5.809E-08	5.80998E-08	164123.73	0.41674
41	1100	1.0909	5.73E-08	5.727E-08	5.7267E-08	5.7256E-08	5.726E-08	5.72636E-08	161761.58	0.41669
42	1125	1.1321	5.57E-08	5.573E-08	5.5732E-08	5.5734E-08	5.573E-08	5.57334E-08	157438.98	0.41667
43	1150	1.1539	5.49E-08	5.492E-08	5.4922E-08	5.4918E-08	5.492E-08	5.4918E-08	155135.59	0.41667
44	1175	1.1765	5.41E-08	5.413E-08	5.4135E-08	5.4132E-08	5.413E-08	5.41322E-08	152915.82	0.41668
45	1200	1.2	5.33E-08	5.329E-08	5.329E-08	5.3288E-08	5.328E-08	5.32904E-08	150537.85	0.41671
46	1225	1.2245	5.25E-08	5.253E-08	5.2534E-08	5.2523E-08	5.252E-08	5.25276E-08	148383.05	0.41668
47	1250	1.25	5.17E-08	5.169E-08	5.1696E-08	5.1689E-08	5.168E-08	5.169E-08	146016.95	0.41669
48	1275	1.2766	5.09E-08	5.092E-08	5.0922E-08	5.0923E-08	5.092E-08	5.09234E-08	143851.41	0.41667
49	1300	1.3044	5.02E-08	5.02E-08	5.0203E-08	5.0201E-08	5.019E-08	5.02004E-08	141809.04	0.41669
50	1325	1.3333	4.94E-08	4.944E-08	4.9438E-08	4.9438E-08	4.944E-08	4.9439E-08	139658.19	0.41667
51	1350	1.3636	4.86E-08	4.862E-08	4.8619E-08	4.8622E-08	4.862E-08	4.86218E-08	137349.72	0.41667
52	1375	1.3636	4.86E-08	4.857E-08	4.8571E-08	4.8572E-08	4.857E-08	4.85734E-08	137212.99	0.41667
53	1400	1.3954	4.78E-08	4.78E-08	4.7793E-08	4.7794E-08	4.78E-08	4.77966E-08	135018.64	0.41669
54	1425	1.4286	4.7E-08	4.701E-08	4.7003E-08	4.7006E-08	4.7E-08	4.70046E-08	132781.36	0.41667
55	1450	1.4634	4.63E-08	4.626E-08	4.6261E-08	4.6259E-08	4.626E-08	4.62604E-08	119379.66	9.47512
56	1475	1.4634	4.62E-08	4.623E-08	4.6226E-08	4.6228E-08	4.623E-08	4.62272E-08	130585.31	0.41667
57	1500	1.5	4.55E-08	4.545E-08	4.545E-08	4.5446E-08	4.544E-08	4.54488E-08	128386.44	0.41668
58	1525	1.5385	4.47E-08	4.468E-08	4.4674E-08	4.4671E-08	4.467E-08	4.46754E-08	126201.69	0.4167
59	1550	1.5385	4.46E-08	4.464E-08	4.4637E-08	4.4635E-08	4.463E-08	4.46372E-08	126093.79	0.41668
60	1575	1.579	4.39E-08	4.388E-08	4.3876E-08	4.3877E-08	4.387E-08	4.38754E-08	123941.81	0.41668
61	1600	1.579	4.39E-08	4.386E-08	4.3855E-08	4.3859E-08	4.386E-08	4.3858E-08	123892.66	0.41668
62	1625	1.6216	4.31E-08	4.31E-08	4.3098E-08	4.3096E-08	4.31E-08	4.30986E-08	121747.46	0.41668
63	1650	1.6667	4.24E-08	4.237E-08	4.2378E-08	4.238E-08	4.238E-08	4.23762E-08	119706.78	0.41668
64	1675	1.6667	4.24E-08	4.235E-08	4.2346E-08	4.2346E-08	4.235E-08	4.23482E-08	119627.68	0.41668
65	1700	1.7143	4.16E-08	4.16E-08	4.1603E-08	4.1602E-08	4.16E-08	4.16032E-08	117523.16	0.41667
66	1725	1.7143	4.16E-08	4.159E-08	4.1592E-08	4.1591E-08	4.159E-08	4.15912E-08	117489.27	0.41667
67	1750	1.7647	4.08E-08	4.082E-08	4.082E-08	4.0821E-08	4.082E-08	4.08194E-08	115309.04	0.41668
68	1775	1.7647	4.08E-08	4.083E-08	4.0834E-08	4.0835E-08	4.084E-08	4.0835E-08	115353.11	0.41667
69	1800	1.8182	4.01E-08	4.006E-08	4.0062E-08	4.0067E-08	4.007E-08	4.00634E-08	113173.45	0.41671
70	1825	1.8182	4.01E-08	4.006E-08	4.006E-08	4.0058E-08	4.006E-08	4.00602E-08	113164.41	0.41668
71	1850	1.875	3.93E-08	3.927E-08	3.9273E-08	3.9275E-08	3.928E-08	3.92728E-08	110940.11	0.41668
72	1875	1.875	3.93E-08	3.928E-08	3.9283E-08	3.928E-08	3.928E-08	3.92822E-08	110966.67	0.41668
73	1900	1.875	3.93E-08	3.926E-08	3.9254E-08	3.9253E-08	3.925E-08	3.92556E-08	110891.53	0.41669
74	1925	1.9355	3.85E-08	3.849E-08	3.8489E-08	3.8491E-08	3.849E-08	3.84888E-08	108725.42	0.41667
75	1950	1.9355	3.85E-08	3.848E-08	3.8478E-08	3.8482E-08	3.848E-08	3.8479E-08	108697.74	0.41667
76	1975	2	3.77E-08	3.768E-08	3.7674E-08	3.7678E-08	3.768E-08	3.76766E-08	106431.07	0.41668
77	2000	2	3.77E-08	3.771E-08	3.7709E-08	3.7711E-08	3.771E-08	3.77086E-08	106521.47	0.41667

b. 10 mL

1. Sampel A

No	F (Hz)	F (kHz)	C1 (F)	C2 (F)	C3 (F)	C4 (F)	C5 (F)	Crata-rata (F)	ε	Kr
1	100	0.1	5.81E-07	5.8E-07	5.8E-07	5.79E-07	5.78E-07	5.79594E-07	1637271	0.42965
2	125	0.125	4.67E-07	4.67E-07	4.66E-07	4.67E-07	4.67E-07	4.66628E-07	1318158	0.41741
3	150	0.15	3.93E-07	3.92E-07	3.91E-07	3.9E-07	3.9E-07	3.91226E-07	1105158	0.43963
4	175	0.1765	3.35E-07	3.35E-07	3.35E-07	3.34E-07	3.34E-07	3.34516E-07	944960	0.42074
5	200	0.2	2.98E-07	2.98E-07	2.98E-07	2.98E-07	2.98E-07	2.97886E-07	841486	0.41882
6	225	0.2308	2.61E-07	2.61E-07	2.61E-07	2.61E-07	2.61E-07	2.6109E-07	737542	0.41943
7	250	0.25	2.43E-07	2.43E-07	2.43E-07	2.43E-07	2.43E-07	2.42712E-07	685627	0.41738
8	275	0.2752	2.23E-07	2.23E-07	2.23E-07	2.23E-07	2.23E-07	2.233E-07	630791	0.41675
9	300	0.3	2.09E-07	2.09E-07	2.09E-07	2.09E-07	2.09E-07	2.09054E-07	590548	0.41739
10	325	0.3243	1.96E-07	1.96E-07	1.96E-07	1.96E-07	1.96E-07	1.95614E-07	552582	0.41701
11	350	0.3509	1.84E-07	1.84E-07	1.84E-07	1.84E-07	1.84E-07	1.83778E-07	519147	0.4173
12	375	0.375	1.74E-07	1.74E-07	1.74E-07	1.74E-07	1.74E-07	1.74414E-07	492695	0.41685
13	400	0.4	1.66E-07	1.66E-07	1.66E-07	1.66E-07	1.66E-07	1.66026E-07	469000	0.41692
14	425	0.4255	1.59E-07	1.59E-07	1.58E-07	1.58E-07	1.58E-07	1.58468E-07	447650	0.41718
15	450	0.4511	1.52E-07	1.52E-07	1.52E-07	1.52E-07	1.52E-07	1.51852E-07	428960	0.41673
16	475	0.4762	1.46E-07	1.46E-07	1.46E-07	1.46E-07	1.46E-07	1.4586E-07	412034	0.41675
17	500	0.5	1.41E-07	1.41E-07	1.41E-07	1.41E-07	1.41E-07	1.40706E-07	397475	0.41668
18	525	0.5263	1.36E-07	1.36E-07	1.36E-07	1.36E-07	1.36E-07	1.3556E-07	382938	0.41676
19	550	0.5505	1.31E-07	1.31E-07	1.31E-07	1.31E-07	1.31E-07	1.31168E-07	370531	0.4167
20	575	0.5769	1.27E-07	1.27E-07	1.27E-07	1.27E-07	1.27E-07	1.27168E-07	359232	0.41674
21	600	0.6	1.24E-07	1.24E-07	1.24E-07	1.24E-07	1.24E-07	1.24016E-07	350328	0.41684
22	625	0.625	1.21E-07	1.21E-07	1.21E-07	1.21E-07	1.21E-07	1.20776E-07	341175	0.41676
23	650	0.6522	1.17E-07	1.17E-07	1.17E-07	1.17E-07	1.17E-07	1.17133E-07	330876	0.41673
24	675	0.6742	1.14E-07	1.14E-07	1.14E-07	1.14E-07	1.14E-07	1.1446E-07	323333	0.41671
25	700	0.6977	1.12E-07	1.12E-07	1.12E-07	1.12E-07	1.12E-07	1.11774E-07	315746	0.41688
26	725	0.7229	1.08E-07	1.08E-07	1.08E-07	1.08E-07	1.08E-07	1.08258E-07	305814	0.41674
27	750	0.75	1.06E-07	1.06E-07	1.06E-07	1.06E-07	1.06E-07	1.05688E-07	298554	0.4167
28	775	0.7792	1.03E-07	1.03E-07	1.03E-07	1.03E-07	1.03E-07	1.03044E-07	291085	0.4167
29	800	0.8	1.01E-07	1.01E-07	1.01E-07	1.01E-07	1.01E-07	1.01146E-07	285723	0.4167
30	825	0.8219	9.93E-08	9.93E-08	9.93E-08	9.93E-08	9.93E-08	9.93356E-08	280609	0.41671
31	850	0.8451	9.72E-08	9.72E-08	9.72E-08	9.72E-08	9.72E-08	9.72014E-08	274580	0.41667
32	875	0.8696	9.54E-08	9.54E-08	9.54E-08	9.54E-08	9.53E-08	9.53666E-08	269397	0.41679
33	900	0.8955	9.35E-08	9.35E-08	9.35E-08	9.35E-08	9.35E-08	9.34686E-08	264036	0.41671
34	925	0.9231	9.15E-08	9.15E-08	9.15E-08	9.15E-08	9.15E-08	9.14938E-08	258457	0.41668
35	950	0.9524	8.95E-08	8.95E-08	8.95E-08	8.95E-08	8.95E-08	8.9498E-08	252819	0.41671
36	975	0.9678	8.84E-08	8.84E-08	8.84E-08	8.84E-08	8.84E-08	8.84242E-08	249786	0.41671
37	1000	1	8.65E-08	8.65E-08	8.65E-08	8.64E-08	8.64E-08	8.64586E-08	244233	0.41672
38	1025	1.017	8.54E-08	8.54E-08	8.54E-08	8.54E-08	8.54E-08	8.54028E-08	241251	0.4167
39	1050	1.0526	8.36E-08	8.35E-08	8.35E-08	8.35E-08	8.35E-08	8.35182E-08	235927	0.41709
40	1075	1.0714	8.37E-08	8.36E-08	8.35E-08	8.34E-08	8.34E-08	8.34948E-08	235861	0.4216
41	1100	1.0909	8.19E-08	8.19E-08	8.19E-08	8.19E-08	8.19E-08	8.1936E-08	231458	0.41669
42	1125	1.1321	7.99E-08	7.99E-08	7.99E-08	7.99E-08	7.98E-08	7.98542E-08	225577	0.41669
43	1150	1.1539	7.88E-08	7.87E-08	7.87E-08	7.87E-08	7.87E-08	7.87358E-08	222418	0.41671
44	1175	1.1765	7.77E-08	7.77E-08	7.77E-08	7.77E-08	7.77E-08	7.76832E-08	219444	0.41669
45	1200	1.2	7.66E-08	7.66E-08	7.66E-08	7.66E-08	7.66E-08	7.66158E-08	216429	0.4167

46	1225	1.2245	7.55E-08	7.55E-08	7.55E-08	7.55E-08	7.55E-08	7.55E-08	7.54716E-08	213197	0.4167
47	1250	1.25	7.44E-08	7.45E-08	7.45E-08	7.45E-08	7.45E-08	7.45E-08	7.44712E-08	210371	0.41674
48	1275	1.2766	7.36E-08	7.35E-08	7.35E-08	7.35E-08	7.35E-08	7.35E-08	7.35466E-08	207759	0.4167
49	1300	1.3044	7.27E-08	7.26E-08	7.26E-08	7.26E-08	7.26E-08	7.26E-08	7.2641E-08	205201	0.4167
50	1325	1.3333	7.14E-08	7.14E-08	7.14E-08	7.14E-08	7.14E-08	7.14E-08	7.14178E-08	201745	0.41674
51	1350	1.3636	7.02E-08	7.02E-08	7.02E-08	7.02E-08	7.02E-08	7.02E-08	7.01874E-08	198269	0.41673
52	1375	1.3636	7E-08	7E-08	7E-08	7E-08	7E-08	7E-08	6.99856E-08	197699	0.41686
53	1400	1.3954	6.88E-08	6.88E-08	6.88E-08	6.88E-08	6.88E-08	6.88E-08	6.8764E-08	194249	0.4167
54	1425	1.4286	6.76E-08	6.76E-08	6.76E-08	6.76E-08	6.76E-08	6.76E-08	6.75792E-08	190902	0.41676
55	1450	1.4634	6.64E-08	6.64E-08	6.64E-08	6.64E-08	6.64E-08	6.64E-08	6.6363E-08	187466	0.4167
56	1475	1.4634	6.63E-08	6.63E-08	6.63E-08	6.63E-08	6.63E-08	6.63E-08	6.6293E-08	187268	0.41668
57	1500	1.5	6.51E-08	6.51E-08	6.51E-08	6.51E-08	6.51E-08	6.51E-08	6.50934E-08	183880	0.41667
58	1525	1.5385	6.36E-08	6.36E-08	6.36E-08	6.36E-08	6.36E-08	6.36E-08	6.3569E-08	179576	0.41678
59	1550	1.5385	6.35E-08	6.35E-08	6.35E-08	6.35E-08	6.35E-08	6.35E-08	6.3467E-08	179311	0.41673
60	1575	1.579	6.23E-08	6.23E-08	6.23E-08	6.23E-08	6.23E-08	6.23E-08	6.2309E-08	176014	0.41668
61	1600	1.579	6.23E-08	6.23E-08	6.22E-08	6.22E-08	6.22E-08	6.22E-08	6.22482E-08	175842	0.41675
62	1625	1.6216	6.1E-08	6.1E-08	6.1E-08	6.1E-08	6.1E-08	6.1E-08	6.10342E-08	172413	0.41668
63	1650	1.6667	5.98E-08	5.98E-08	5.98E-08	5.98E-08	5.98E-08	5.98E-08	5.98264E-08	169001	0.4167
64	1675	1.6667	5.98E-08	5.98E-08	5.98E-08	5.98E-08	5.98E-08	5.98E-08	5.98166E-08	168973	0.4168
65	1700	1.7143	5.9E-08	5.9E-08	5.9E-08	5.9E-08	5.9E-08	5.9E-08	5.90016E-08	166671	0.41689
66	1725	1.7143	5.89E-08	5.89E-08	5.89E-08	5.89E-08	5.89E-08	5.88E-08	5.88518E-08	166248	0.41668
67	1750	1.7647	5.77E-08	5.77E-08	5.77E-08	5.77E-08	5.77E-08	5.77E-08	5.77096E-08	163021	0.41668
68	1775	1.7647	5.76E-08	5.76E-08	5.76E-08	5.76E-08	5.76E-08	5.76E-08	5.76036E-08	162722	0.41671
69	1800	1.8182	5.64E-08	5.64E-08	5.64E-08	5.64E-08	5.64E-08	5.64E-08	5.6398E-08	159316	0.41682
70	1825	1.8182	5.63E-08	5.63E-08	5.63E-08	5.63E-08	5.63E-08	5.63E-08	5.62776E-08	158976	0.41667
71	1850	1.875	5.51E-08	5.51E-08	5.51E-08	5.51E-08	5.51E-08	5.51E-08	5.51202E-08	155707	0.41676
72	1875	1.875	5.51E-08	5.51E-08	5.51E-08	5.51E-08	5.51E-08	5.51E-08	5.50916E-08	155266	0.41667
73	1900	1.875	5.51E-08	5.51E-08	5.51E-08	5.51E-08	5.51E-08	5.51E-08	5.51414E-08	155767	0.4167
74	1925	1.9355	5.39E-08	5.39E-08	5.39E-08	5.39E-08	5.39E-08	5.39E-08	5.39342E-08	152356	0.41668
75	1950	1.9355	5.38E-08	5.38E-08	5.38E-08	5.38E-08	5.38E-08	5.38E-08	5.3834E-08	152073	0.4167
76	1975	2	5.26E-08	5.26E-08	5.26E-08	5.26E-08	5.26E-08	5.26E-08	5.25956E-08	148575	0.41672
77	2000	2	5.27E-08	5.27E-08	5.27E-08	5.27E-08	5.27E-08	5.27E-08	5.26798E-08	148813	0.41684

2. Sampel B

No	F (Hz)	F (kHz)	C1 (F)	C2 (F)	C3 (F)	C4 (F)	C5 (F)	C rata-rata (F)	ϵ	Kr
1	100	0.1	4.54E-07	4.54E-07	4.54E-07	4.54E-07	4.53E-07	4.5387E-07	1282119	0.41768
2	125	0.125	3.65E-07	3.66E-07	3.65E-07	3.65E-07	3.64E-07	3.6486E-07	1030695	0.42767
3	150	0.15	3.06E-07	3.05E-07	3.04E-07	3.05E-07	3.05E-07	3.0497E-07	861497	0.43057
4	175	0.1765	2.6E-07	2.6E-07	2.6E-07	2.6E-07	2.6E-07	2.60218E-07	735079	0.41695
5	200	0.2	2.31E-07	2.31E-07	2.31E-07	2.31E-07	2.31E-07	2.31012E-07	652576	0.41771
6	225	0.2308	2.02E-07	2.01E-07	2.01E-07	2.01E-07	2.01E-07	2.01456E-07	569885	0.41678
7	250	0.25	1.86E-07	1.86E-07	1.86E-07	1.86E-07	1.86E-07	1.8619E-07	525960	0.4172
8	275	0.2752	1.69E-07	1.69E-07	1.69E-07	1.69E-07	1.69E-07	1.69318E-07	478299	0.41686
9	300	0.3	1.56E-07	1.56E-07	1.56E-07	1.55E-07	1.56E-07	1.55632E-07	439638	0.41893
10	325	0.3243	1.45E-07	1.45E-07	1.45E-07	1.44E-07	1.44E-07	1.44524E-07	408260	0.41774
11	350	0.3509	1.34E-07	1.34E-07	1.34E-07	1.34E-07	1.34E-07	1.3413E-07	378898	0.41866
12	375	0.375	1.26E-07	1.26E-07	1.26E-07	1.26E-07	1.26E-07	1.26104E-07	356226	0.4181
13	400	0.4	1.12E-07	1.12E-07	1.12E-07	1.13E-07	1.13E-07	1.12528E-07	317876	0.4187
14	425	0.4255	1.1E-07	1.11E-07	1.11E-07	1.11E-07	1.11E-07	1.10558E-07	312311	0.41768
15	450	0.4511	1.07E-07	1.07E-07	1.07E-07	1.07E-07	1.07E-07	1.06728E-07	301492	0.41723

16	475	0.4762	1.02E-07	1.02E-07	1.02E-07	1.02E-07	1.02E-07	1.01744E-07	287412	0.41679
17	500	0.5	9.74E-08	9.74E-08	9.74E-08	9.74E-08	9.75E-08	9.74304E-08	275227	0.41676
18	525	0.5263	9.19E-08	9.18E-08	9.18E-08	9.18E-08	9.18E-08	9.18046E-08	259335	0.41736
19	550	0.5505	8.84E-08	8.83E-08	8.84E-08	8.83E-08	8.83E-08	8.83438E-08	249559	0.41705
20	575	0.5769	8.49E-08	8.49E-08	8.49E-08	8.49E-08	8.5E-08	8.4932E-08	239921	0.41695
21	600	0.6	8.23E-08	8.22E-08	8.22E-08	8.22E-08	8.22E-08	8.22462E-08	232334	0.4169
22	625	0.625	7.95E-08	7.95E-08	7.95E-08	7.96E-08	7.95E-08	7.95256E-08	224649	0.41681
23	650	0.6522	7.7E-08	7.7E-08	7.7E-08	7.68E-08	7.67E-08	7.69286E-08	217312	0.42325
24	675	0.6742	7.49E-08	7.48E-08	7.48E-08	7.48E-08	7.48E-08	7.48308E-08	211386	0.41731
25	700	0.6977	7.27E-08	7.28E-08	7.28E-08	7.28E-08	7.27E-08	7.27488E-08	205505	0.41693
26	725	0.7229	7.07E-08	7.07E-08	7.07E-08	7.07E-08	7.07E-08	7.06792E-08	199659	0.4168
27	750	0.75	6.89E-08	6.88E-08	6.88E-08	6.88E-08	6.88E-08	6.8823E-08	194415	0.41685
28	775	0.7792	6.68E-08	6.68E-08	6.67E-08	6.67E-08	6.67E-08	6.67462E-08	188549	0.41945
29	800	0.8	6.55E-08	6.55E-08	6.55E-08	6.55E-08	6.55E-08	6.5524E-08	185096	0.41683
30	825	0.8219	6.42E-08	6.41E-08	6.42E-08	6.42E-08	6.42E-08	6.41946E-08	181341	0.41737
31	850	0.8451	6.3E-08	6.3E-08	6.29E-08	6.29E-08	6.29E-08	6.29408E-08	177799	0.41713
32	875	0.8696	6.18E-08	6.18E-08	6.18E-08	6.18E-08	6.18E-08	6.17892E-08	174546	0.41682
33	900	0.8955	6.05E-08	6.05E-08	6.05E-08	6.05E-08	6.05E-08	6.04802E-08	170848	0.41675
34	925	0.9231	5.92E-08	5.92E-08	5.92E-08	5.92E-08	5.92E-08	5.9168E-08	167141	0.41676
35	950	0.9524	5.78E-08	5.79E-08	5.79E-08	5.79E-08	5.79E-08	5.78678E-08	163468	0.41681
36	975	0.9678	5.72E-08	5.72E-08	5.72E-08	5.72E-08	5.72E-08	5.71982E-08	161577	0.41697
37	1000	1	5.75E-08	5.74E-08	5.74E-08	5.75E-08	5.75E-08	5.7446E-08	162277	0.41879
38	1025	1.017	5.84E-08	5.86E-08	5.84E-08	5.83E-08	5.84E-08	5.84234E-08	165038	0.42791
39	1050	1.0526	5.59E-08	5.58E-08	5.58E-08	5.58E-08	5.58E-08	5.58206E-08	157685	0.41734
40	1075	1.0714	5.47E-08	5.47E-08	5.47E-08	5.47E-08	5.46E-08	5.4687E-08	154483	0.41729
41	1100	1.0909	5.37E-08	5.37E-08	5.37E-08	5.37E-08	5.37E-08	5.36818E-08	151644	0.41684
42	1125	1.1321	5.23E-08	5.22E-08	5.23E-08	5.23E-08	5.23E-08	5.22666E-08	147646	0.41703
43	1150	1.1539	5.14E-08	5.15E-08	5.15E-08	5.15E-08	5.15E-08	5.15058E-08	145497	0.41814
44	1175	1.1765	5.08E-08	5.09E-08	5.08E-08	5.09E-08	5.1E-08	5.08766E-08	143719	0.41964
45	1200	1.2	5.04E-08	5.03E-08	5.03E-08	5.03E-08	5.03E-08	5.03048E-08	142104	0.41814
46	1225	1.2245	5.05E-08	5.05E-08	5.06E-08	5.06E-08	5.06E-08	5.0562E-08	142831	0.42056
47	1250	1.25	5.08E-08	5.09E-08	5.09E-08	5.09E-08	5.09E-08	5.08688E-08	143697	0.41739
48	1275	1.2766	5.1E-08	5.1E-08	5.1E-08	5.11E-08	5.11E-08	5.10298E-08	144152	0.41784
49	1300	1.3044	5.1E-08	5.1E-08	5.11E-08	5.11E-08	5.12E-08	5.10964E-08	144340	0.42112
50	1325	1.3333	5.11E-08	5.11E-08	5.11E-08	5.11E-08	5.12E-08	5.11238E-08	144418	0.4183
51	1350	1.3636	5.1E-08	5.09E-08	5.1E-08	5.1E-08	5.1E-08	5.09632E-08	143964	0.41709
52	1375	1.3636	5.15E-08	5.16E-08	5.15E-08	5.15E-08	5.15E-08	5.1511E-08	145511	0.41932
53	1400	1.3954	4.96E-08	4.95E-08	4.94E-08	4.94E-08	4.93E-08	4.94288E-08	139629	0.42607
54	1425	1.4286	4.58E-08	4.58E-08	4.58E-08	4.58E-08	4.58E-08	4.58352E-08	129478	0.41672
55	1450	1.4634	4.5E-08	4.5E-08	4.5E-08	4.5E-08	4.5E-08	4.5005E-08	127133	0.41668
56	1475	1.4634	4.51E-08	4.52E-08	4.52E-08	4.52E-08	4.52E-08	4.51884E-08	127651	0.41842
57	1500	1.5	4.5E-08	4.5E-08	4.5E-08	4.5E-08	4.5E-08	4.50052E-08	127133	0.41705
58	1525	1.5385	4.48E-08	4.48E-08	4.49E-08	4.49E-08	4.49E-08	4.48778E-08	126773	0.42047
59	1550	1.5385	4.56E-08	4.56E-08	4.56E-08	4.56E-08	4.56E-08	4.56204E-08	128871	0.41697
60	1575	1.579	4.55E-08	4.55E-08	4.56E-08	4.56E-08	4.56E-08	4.55716E-08	128733	0.42094

61	1600	1.579	4.63E-08	4.63E-08	4.63E-08	4.63E-08	4.64E-08	4.63054E-08	130806	0.41865
62	1625	1.6216	4.6E-08	4.6E-08	4.61E-08	4.61E-08	4.61E-08	4.60576E-08	130106	0.41805
63	1650	1.6667	4.56E-08	4.56E-08	4.57E-08	4.57E-08	4.57E-08	4.56534E-08	128964	0.41831
64	1675	1.6667	4.52E-08	4.52E-08	4.53E-08	4.53E-08	4.53E-08	4.52666E-08	127872	0.42079
65	1700	1.7143	4.51E-08	4.51E-08	4.52E-08	4.52E-08	4.52E-08	4.5159E-08	127568	0.41693
66	1725	1.7143	4.56E-08	4.56E-08	4.56E-08	4.57E-08	4.57E-08	4.56446E-08	128940	0.41822
67	1750	1.7647	4.51E-08	4.51E-08	4.52E-08	4.52E-08	4.52E-08	4.51432E-08	127523	0.41764
68	1775	1.7647	4.54E-08	4.54E-08	4.54E-08	4.54E-08	4.54E-08	4.54166E-08	128295	0.4169
69	1800	1.8182	4.48E-08	4.48E-08	4.48E-08	4.48E-08	4.48E-08	4.47922E-08	126532	0.41683
70	1825	1.8182	4.49E-08	4.49E-08	4.49E-08	4.49E-08	4.5E-08	4.49377E-08	126941	0.41694
71	1850	1.875	4.42E-08	4.42E-08	4.42E-08	4.42E-08	4.42E-08	4.42022E-08	124865	0.41671
72	1875	1.875	4.41E-08	4.41E-08	4.41E-08	4.41E-08	4.41E-08	4.406E-08	124463	0.4167
73	1900	1.875	4.39E-08	4.39E-08	4.39E-08	4.39E-08	4.39E-08	4.3868E-08	123921	0.41687
74	1925	1.9355	4.28E-08	4.27E-08	4.29E-08	4.28E-08	4.28E-08	4.278E-08	120847	0.42502
75	1950	1.9355	4.21E-08	4.21E-08	4.21E-08	4.21E-08	4.2E-08	4.20896E-08	118897	0.41894
76	1975	2	4.18E-08	4.18E-08	4.18E-08	4.18E-08	4.18E-08	4.1759E-08	117963	0.41671
77	2000	2	4.09E-08	4.1E-08	4.1E-08	4.1E-08	4.1E-08	4.09662E-08	115724	0.41888

3. Sampel C

No	F (Hz)	F (kHz)	C1 (F)	C2 (F)	C3 (F)	C4 (F)	C5 (F)	C rata-rata (F)	ε	Kr
1	100	0.1	3.15E-07	3.15E-07	3.15E-07	3.14E-07	3.14E-07	3.14622E-07	888763	0.42376
2	125	0.125	2.58E-07	2.58E-07	2.58E-07	2.57E-07	2.57E-07	2.57582E-07	727633	0.42136
3	150	0.15	2.21E-07	2.21E-07	2.21E-07	2.21E-07	2.21E-07	2.2089E-07	623983	0.41834
4	175	0.1765	1.94E-07	1.93E-07	1.93E-07	1.93E-07	1.93E-07	1.93348E-07	546181	0.41782
5	200	0.2	1.75E-07	1.75E-07	1.75E-07	1.75E-07	1.75E-07	1.75236E-07	495017	0.41752
6	225	0.2308	1.57E-07	1.57E-07	1.57E-07	1.57E-07	1.57E-07	1.57228E-07	444147	0.41674
7	250	0.25	1.49E-07	1.49E-07	1.49E-07	1.49E-07	1.49E-07	1.48796E-07	420328	0.41669
8	275	0.2752	1.4E-07	1.4E-07	1.4E-07	1.4E-07	1.4E-07	1.3981E-07	394944	0.41671
9	300	0.3	1.32E-07	1.32E-07	1.32E-07	1.32E-07	1.32E-07	1.3191E-07	372627	0.41677
10	325	0.3243	1.25E-07	1.25E-07	1.25E-07	1.25E-07	1.25E-07	1.25118E-07	353441	0.41672
11	350	0.3509	1.19E-07	1.19E-07	1.19E-07	1.19E-07	1.19E-07	1.18906E-07	335893	0.41669
12	375	0.375	1.14E-07	1.14E-07	1.14E-07	1.14E-07	1.14E-07	1.1422E-07	322655	0.41668
13	400	0.4	1.1E-07	1.1E-07	1.1E-07	1.1E-07	1.1E-07	1.09732E-07	309977	0.41673
14	425	0.4255	1.06E-07	1.06E-07	1.06E-07	1.06E-07	1.06E-07	1.0589E-07	299124	0.41672
15	450	0.4511	1.02E-07	1.02E-07	1.02E-07	1.02E-07	1.02E-07	1.02258E-07	288864	0.41675
16	475	0.4762	9.92E-08	9.92E-08	9.93E-08	9.93E-08	9.93E-08	9.92526E-08	280375	0.41674
17	500	0.5	9.56E-08	9.59E-08	9.59E-08	9.59E-08	9.59E-08	9.58146E-08	270663	0.42174
18	525	0.5263	9.4E-08	9.4E-08	9.4E-08	9.4E-08	9.4E-08	9.39766E-08	265471	0.41669
19	550	0.5505	9.16E-08	9.16E-08	9.16E-08	9.16E-08	9.16E-08	9.16194E-08	258812	0.41667
20	575	0.5769	8.93E-08	8.93E-08	8.93E-08	8.93E-08	8.93E-08	8.92732E-08	252184	0.41676
21	600	0.6	8.73E-08	8.73E-08	8.74E-08	8.74E-08	8.74E-08	8.7352E-08	246757	0.41675
22	625	0.625	8.54E-08	8.54E-08	8.54E-08	8.54E-08	8.54E-08	8.54094E-08	241269	0.41674
23	650	0.6522	8.35E-08	8.35E-08	8.35E-08	8.35E-08	8.35E-08	8.34646E-08	235776	0.41668
24	675	0.6742	8.2E-08	8.2E-08	8.2E-08	8.2E-08	8.2E-08	8.1995E-08	231624	0.41674
25	700	0.6977	8.05E-08	8.05E-08	8.05E-08	8.05E-08	8.05E-08	8.05358E-08	227502	0.41668
26	725	0.7229	7.9E-08	7.9E-08	7.9E-08	7.9E-08	7.9E-08	7.9034E-08	223258	0.41667
27	750	0.75	7.74E-08	7.74E-08	7.74E-08	7.74E-08	7.74E-08	7.74336E-08	218739	0.41669
28	775	0.7792	7.58E-08	7.58E-08	7.58E-08	7.59E-08	7.48E-08	7.56354E-08	213659	0.49135
29	800	0.8	7.48E-08	7.49E-08	7.49E-08	7.49E-08	7.49E-08	7.4854E-08	211452	0.4167
30	825	0.8219	7.39E-08	7.38E-08	7.39E-08	7.39E-08	7.38E-08	7.3864E-08	208655	0.41694

31	850	0.8451	7.16E-08	7.15E-08	7.15E-08	7.15E-08	7.15E-08	7.15348E-08	202076	0.41708
32	875	0.8696	6.88E-08	6.87E-08	6.87E-08	6.87E-08	6.87E-08	6.87248E-08	194138	0.41715
33	900	0.8955	6.67E-08	6.67E-08	6.67E-08	6.67E-08	6.67E-08	6.67282E-08	188498	0.41681
34	925	0.9231	6.45E-08	6.45E-08	6.45E-08	6.44E-08	6.45E-08	6.44974E-08	182196	0.41808
35	950	0.9524	6.22E-08	6.22E-08	6.22E-08	6.22E-08	6.22E-08	6.21954E-08	175693	0.41691
36	975	0.9678	6.05E-08	6.05E-08	6.05E-08	6.05E-08	6.05E-08	6.05034E-08	170914	0.41682
37	1000	1	5.9E-08	5.9E-08	5.9E-08	5.9E-08	5.9E-08	5.89926E-08	166646	0.41713
38	1025	1.017	5.77E-08	5.77E-08	5.77E-08	5.78E-08	5.78E-08	5.7719E-08	163048	0.41783
39	1050	1.0526	5.64E-08	5.64E-08	5.64E-08	5.64E-08	5.64E-08	5.63832E-08	159275	0.417
40	1075	1.0714	5.46E-08	5.46E-08	5.46E-08	5.46E-08	5.46E-08	5.45856E-08	154197	0.41705
41	1100	1.0909	5.32E-08	5.31E-08	5.31E-08	5.31E-08	5.31E-08	5.31266E-08	150075	0.41752
42	1125	1.1321	5.17E-08	5.17E-08	5.17E-08	5.17E-08	5.18E-08	5.17448E-08	146172	0.41669
43	1150	1.1539	5.1E-08	5.1E-08	5.1E-08	5.1E-08	5.1E-08	5.09964E-08	144058	0.41711
44	1175	1.1765	5.21E-08	5.19E-08	5.17E-08	5.16E-08	5.15E-08	5.17782E-08	146266	0.46481
45	1200	1.2	5.03E-08	5.02E-08	5.02E-08	5.02E-08	5.02E-08	5.0217E-08	141856	0.41706
46	1225	1.2245	4.89E-08	4.9E-08	4.89E-08	4.9E-08	4.89E-08	4.8946E-08	138266	0.41695
47	1250	1.25	4.82E-08	4.82E-08	4.82E-08	4.82E-08	4.82E-08	4.81916E-08	136134	0.41704
48	1275	1.2766	4.76E-08	4.75E-08	4.75E-08	4.75E-08	4.75E-08	4.75448E-08	134307	0.4168
49	1300	1.3044	4.64E-08	4.64E-08	4.64E-08	4.64E-08	4.64E-08	4.64108E-08	131104	0.41675
50	1325	1.3333	4.58E-08	4.58E-08	4.58E-08	4.58E-08	4.58E-08	4.58302E-08	129464	0.41667
51	1350	1.3636	4.54E-08	4.54E-08	4.54E-08	4.54E-08	4.54E-08	4.53658E-08	128152	0.41676
52	1375	1.3636	4.5E-08	4.49E-08	4.49E-08	4.49E-08	4.49E-08	4.49262E-08	126910	0.41727
53	1400	1.3954	4.43E-08	4.43E-08	4.43E-08	4.43E-08	4.43E-08	4.43046E-08	125154	0.41679
54	1425	1.4286	4.38E-08	4.38E-08	4.38E-08	4.38E-08	4.38E-08	4.3791E-08	123703	0.41716
55	1450	1.4634	4.32E-08	4.32E-08	4.32E-08	4.32E-08	4.32E-08	4.3204E-08	122045	0.41671
56	1475	1.4634	4.26E-08	4.26E-08	4.26E-08	4.26E-08	4.26E-08	4.26248E-08	120409	0.41682
57	1500	1.5	4.25E-08	4.25E-08	4.25E-08	4.25E-08	4.25E-08	4.2473E-08	119980	0.41686
58	1525	1.5385	4.2E-08	4.2E-08	4.2E-08	4.2E-08	4.2E-08	4.19906E-08	118618	0.41697
59	1550	1.5385	4.21E-08	4.21E-08	4.22E-08	4.22E-08	4.22E-08	4.2157E-08	119088	0.41929
60	1575	1.579	4.09E-08	4.09E-08	4.09E-08	4.09E-08	4.09E-08	4.0899E-08	115534	0.41671
61	1600	1.579	4.06E-08	4.06E-08	4.07E-08	4.07E-08	4.09E-08	4.06692E-08	114885	0.44142
62	1625	1.6216	4.02E-08	4.03E-08	4.03E-08	4.03E-08	4.03E-08	4.0316E-08	113887	0.42002
63	1650	1.6667	4.04E-08	4.04E-08	4.04E-08	4.04E-08	4.04E-08	4.0367E-08	114031	0.41677
64	1675	1.6667	3.98E-08	4.11E-08	4.11E-08	4.11E-08	4.11E-08	4.07992E-08	115252	0.75794
65	1700	1.7143	4.05E-08	4.05E-08	4.05E-08	4.05E-08	4.05E-08	4.04844E-08	114363	0.41693
66	1725	1.7143	4.07E-08	4.07E-08	4.07E-08	4.07E-08	4.07E-08	4.0741E-08	115088	0.41671
67	1750	1.7647	4.01E-08	4.01E-08	4.01E-08	4.01E-08	4.01E-08	4.00744E-08	113205	0.41717
68	1775	1.7647	4.02E-08	4.02E-08	4.02E-08	4.02E-08	4.02E-08	4.0161E-08	113449	0.41672
69	1800	1.8182	3.94E-08	3.94E-08	3.94E-08	3.94E-08	3.94E-08	3.94108E-08	111330	0.4168
70	1825	1.8182	3.89E-08	3.89E-08	3.88E-08	3.88E-08	3.89E-08	3.88544E-08	109758	0.41695
71	1850	1.875	3.9E-08	3.9E-08	3.9E-08	3.9E-08	3.9E-08	3.90204E-08	110227	0.41715
72	1875	1.875	3.84E-08	3.84E-08	3.84E-08	3.84E-08	3.84E-08	3.8439E-08	108585	0.4167
73	1900	1.875	3.85E-08	3.85E-08	3.85E-08	3.85E-08	3.85E-08	3.84944E-08	108741	0.41671
74	1925	1.9355	3.78E-08	3.78E-08	3.78E-08	3.78E-08	3.78E-08	3.7775E-08	106709	0.41695
75	1950	1.9355	3.79E-08	3.79E-08	3.79E-08	3.79E-08	3.79E-08	3.79106E-08	107092	0.41679
76	1975	2	3.77E-08	3.77E-08	3.77E-08	3.77E-08	3.77E-08	3.76714E-08	106416	0.41676
77	2000	2	3.76E-08	3.76E-08	3.76E-08	3.76E-08	3.76E-08	3.76232E-08	106280	0.41681

4. Sampel D

No	F (Hz)	F (kHz)	C1 (F)	C2 (F)	C3 (F)	C4 (F)	C5 (F)	C rata-rata (F)	ϵ_r	Kr
1	100	0.1	2.52E-07	2.52E-07	2.52E-07	2.5E-07	2.5E-07	2.5102E-07	709096	0.46643
2	125	0.125	2.25E-07	2.25E-07	2.24E-07	2.24E-07	2.29E-07	2.25402E-07	636729	0.54511
3	150	0.15	2.09E-07	1.96E-07	1.96E-07	1.96E-07	1.96E-07	1.9875E-07	561441	1.32988
4	175	0.1765	1.81E-07	1.81E-07	1.81E-07	1.81E-07	1.81E-07	1.80986E-07	511260	0.41803
5	200	0.2	1.71E-07	1.71E-07	1.71E-07	1.71E-07	1.71E-07	1.70668E-07	482113	0.41701
6	225	0.2308	1.56E-07	1.6E-07	1.6E-07	1.6E-07	1.6E-07	1.59452E-07	450429	0.65003
7	250	0.25	1.55E-07	1.55E-07	1.56E-07	1.55E-07	1.47E-07	1.53856E-07	434621	1.14599
8	275	0.2752	1.48E-07	1.48E-07	1.48E-07	1.49E-07	1.5E-07	1.48732E-07	420147	0.48607
9	300	0.3	1.43E-07	1.43E-07	1.43E-07	1.43E-07	1.43E-07	1.43076E-07	404169	0.42018
10	325	0.3243	1.35E-07	1.39E-07	1.38E-07	1.38E-07	1.38E-07	1.37548E-07	388554	0.67626
11	350	0.3509	1.34E-07	1.34E-07	1.34E-07	1.34E-07	1.33E-07	1.33542E-07	377237	0.41754
12	375	0.375	1.13E-07	1.13E-07	1.13E-07	1.13E-07	1.13E-07	1.1279E-07	318616	0.4169
13	400	0.4	1.05E-07	1.05E-07	1.05E-07	1.05E-07	1.05E-07	1.05306E-07	297475	0.41685
14	425	0.4255	9.95E-08	9.93E-08	9.92E-08	9.9E-08	9.9E-08	9.91944E-08	280210	0.43001
15	450	0.4511	9.31E-08	9.27E-08	9.28E-08	9.28E-08	9.25E-08	9.27824E-08	262097	0.42902
16	475	0.4762	8.72E-08	8.71E-08	8.71E-08	8.71E-08	8.71E-08	8.71298E-08	246129	0.41744
17	500	0.5	8.26E-08	8.24E-08	8.26E-08	8.26E-08	8.26E-08	8.25548E-08	233206	0.41912
18	525	0.5263	7.87E-08	7.91E-08	7.9E-08	7.9E-08	7.9E-08	7.89462E-08	223012	0.4256
19	550	0.5505	7.53E-08	7.54E-08	7.56E-08	7.58E-08	7.58E-08	7.55694E-08	213473	0.43585
20	575	0.5769	7.16E-08	7.16E-08	7.15E-08	7.16E-08	7.16E-08	7.1584E-08	202215	0.41709
21	600	0.6	6.83E-08	6.83E-08	6.83E-08	6.82E-08	6.82E-08	6.82588E-08	192821	0.41908
22	625	0.625	6.49E-08	6.5E-08	6.5E-08	6.5E-08	6.49E-08	6.49402E-08	183447	0.41731
23	650	0.6522	6.3E-08	6.34E-08	6.35E-08	6.36E-08	6.35E-08	6.34176E-08	179146	0.44749
24	675	0.6742	6.05E-08	6.05E-08	6.05E-08	6.04E-08	6.04E-08	6.04536E-08	170773	0.41943
25	700	0.6977	5.78E-08	5.78E-08	5.78E-08	5.78E-08	5.78E-08	5.77938E-08	163259	0.41681
26	725	0.7229	5.53E-08	5.53E-08	5.54E-08	5.54E-08	5.53E-08	5.53464E-08	156346	0.41672
27	750	0.75	5.31E-08	5.31E-08	5.29E-08	5.3E-08	5.29E-08	5.29954E-08	149705	0.42172
28	775	0.7792	5.07E-08	5.07E-08	5.07E-08	5.07E-08	5.07E-08	5.07158E-08	143265	0.41736
29	800	0.8	4.93E-08	4.93E-08	4.93E-08	4.93E-08	4.93E-08	4.93012E-08	139269	0.41681
30	825	0.8219	4.81E-08	4.81E-08	4.8E-08	4.8E-08	4.8E-08	4.80038E-08	135604	0.41913
31	850	0.8451	4.67E-08	4.67E-08	4.67E-08	4.67E-08	4.69E-08	4.67416E-08	132038	0.42427
32	875	0.8696	4.55E-08	4.55E-08	4.55E-08	4.55E-08	4.55E-08	4.54818E-08	128480	0.41731
33	900	0.8955	4.4E-08	4.4E-08	4.4E-08	4.4E-08	4.39E-08	4.3997E-08	124285	0.42591
34	925	0.9231	4.26E-08	4.26E-08	4.26E-08	4.26E-08	4.26E-08	4.25876E-08	120304	0.4175
35	950	0.9524	4.12E-08	4.11E-08	4.12E-08	4.12E-08	4.11E-08	4.11454E-08	116230	0.41768
36	975	0.9678	4.09E-08	4.09E-08	4.09E-08	4.09E-08	4.09E-08	4.09122E-08	115571	0.4178
37	1000	1	3.9E-08	3.9E-08	3.9E-08	3.9E-08	3.9E-08	3.90246E-08	110239	0.41685
38	1025	1.017	3.78E-08	3.74E-08	3.74E-08	3.73E-08	3.72E-08	3.73988E-08	105646	0.51025
39	1050	1.0526	3.58E-08	3.58E-08	3.57E-08	3.57E-08	3.57E-08	3.5735E-08	100946	0.41949
40	1075	1.0714	3.47E-08	3.47E-08	3.46E-08	3.46E-08	3.46E-08	3.4652E-08	97887.6	0.42197
41	1100	1.0909	3.36E-08	3.36E-08	3.35E-08	3.35E-08	3.35E-08	3.3538E-08	94740.7	0.42357
42	1125	1.1321	3.1E-08	3.1E-08	3.1E-08	3.1E-08	3.1E-08	3.10016E-08	87575.1	0.41751
43	1150	1.1539	2.95E-08	2.95E-08	2.94E-08	2.94E-08	2.84E-08	2.92236E-08	82552.5	0.8127
44	1175	1.1765	2.86E-08	2.86E-08	2.86E-08	2.86E-08	2.86E-08	2.85694E-08	80704.5	0.41682
45	1200	1.2	2.67E-08	2.66E-08	2.65E-08	2.64E-08	2.63E-08	2.65086E-08	74883.1	0.48227
46	1225	1.2245	2.46E-08	2.46E-08	2.46E-08	2.45E-08	2.44E-08	2.45468E-08	69341.2	0.43994
47	1250	1.25	2.55E-08	2.54E-08	2.54E-08	2.53E-08	2.54E-08	2.54112E-08	71783.1	0.43862
48	1275	1.2766	2.46E-08	2.46E-08	2.46E-08	2.46E-08	2.46E-08	2.4589E-08	69460.5	0.4174
49	1300	1.3044	2.36E-08	2.36E-08	2.36E-08	2.37E-08	2.36E-08	2.36326E-08	66758.8	0.41839
50	1325	1.3333	2.28E-08	2.28E-08	2.27E-08	2.27E-08	2.27E-08	2.27446E-08	64250.3	0.41795

51	1350	1.3636	2.21E-08	2.21E-08	2.21E-08	2.21E-08	2.21E-08	2.20942E-08	62413	0.41794
52	1375	1.3636	2.15E-08	2.15E-08	2.15E-08	2.15E-08	2.15E-08	2.15354E-08	60834.5	0.41704
53	1400	1.3954	2.22E-08	2.21E-08	2.21E-08	2.21E-08	2.21E-08	2.211E-08	62457.6	0.42359
54	1425	1.4286	2.1E-08	2.1E-08	2.1E-08	2.1E-08	2.1E-08	2.1001E-08	59324.9	0.42026
55	1450	1.4634	2.02E-08	2.02E-08	2.02E-08	2.02E-08	2.02E-08	2.01722E-08	56983.6	0.41908
56	1475	1.4634	1.98E-08	1.98E-08	1.98E-08	1.99E-08	2E-08	1.98576E-08	56094.9	0.43509
57	1500	1.5	1.96E-08	1.96E-08	1.96E-08	1.96E-08	1.96E-08	1.95908E-08	55341.2	0.42349
58	1525	1.5385	1.89E-08	1.89E-08	1.89E-08	1.89E-08	1.89E-08	1.88904E-08	53362.7	0.4189
59	1550	1.5385	1.88E-08	1.88E-08	1.88E-08	1.88E-08	1.88E-08	1.88156E-08	53151.4	0.41768
60	1575	1.579	1.82E-08	1.82E-08	1.82E-08	1.82E-08	1.82E-08	1.81912E-08	51387.6	0.41698
61	1600	1.579	1.83E-08	1.83E-08	1.83E-08	1.83E-08	1.83E-08	1.83086E-08	51719.2	0.41683
62	1625	1.6216	1.77E-08	1.77E-08	1.77E-08	1.77E-08	1.77E-08	1.77188E-08	50053.1	0.41847
63	1650	1.6667	1.71E-08	1.71E-08	1.71E-08	1.71E-08	1.7E-08	1.70586E-08	48188.1	0.41737
64	1675	1.6667	1.68E-08	1.68E-08	1.68E-08	1.68E-08	1.68E-08	1.6822E-08	47519.8	0.41756
65	1700	1.7143	1.64E-08	1.64E-08	1.63E-08	1.64E-08	1.64E-08	1.63752E-08	46257.6	0.42015
66	1725	1.7143	1.63E-08	1.63E-08	1.63E-08	1.63E-08	1.63E-08	1.63342E-08	46141.8	0.41763
67	1750	1.7647	1.58E-08	1.58E-08	1.57E-08	1.57E-08	1.58E-08	1.57484E-08	44487	0.41681
68	1775	1.7647	1.58E-08	1.58E-08	1.58E-08	1.58E-08	1.58E-08	1.57712E-08	44551.4	0.41676
69	1800	1.8182	1.54E-08	1.54E-08	1.54E-08	1.54E-08	1.54E-08	1.541E-08	43531.1	0.41722
70	1825	1.8182	1.51E-08	1.51E-08	1.51E-08	1.51E-08	1.51E-08	1.5105E-08	42669.5	0.41858
71	1850	1.875	1.47E-08	1.47E-08	1.47E-08	1.47E-08	1.48E-08	1.47364E-08	41628.2	0.41993
72	1875	1.875	1.48E-08	1.48E-08	1.49E-08	1.49E-08	1.48E-08	1.4826E-08	41881.4	0.43621
73	1900	1.875	1.48E-08	1.48E-08	1.48E-08	1.48E-08	1.48E-08	1.4812E-08	41841.8	0.41774
74	1925	1.9355	1.42E-08	1.42E-08	1.42E-08	1.42E-08	1.42E-08	1.4184E-08	40067.8	0.4189
75	1950	1.9355	1.42E-08	1.42E-08	1.42E-08	1.42E-08	1.42E-08	1.41702E-08	40028.8	0.41769
76	1975	2	1.37E-08	1.37E-08	1.37E-08	1.37E-08	1.37E-08	1.36692E-08	38613.6	0.41679
77	2000	2	1.36E-08	1.36E-08	1.36E-08	1.36E-08	1.36E-08	1.3566E-08	38322	0.4171

c. 20 mL

1. Sampel A

No	F (Hz)	F (kHz)	C1 (F)	C2 (F)	C3 (F)	C4 (F)	C5 (F)	C rata-rata (F)	ε	Kr
1	100	0.1	5.58E-07	5.59E-07	5.61E-07	5.63E-07	5.63E-07	5.60758E-07	1584062	0.4541
2	125	0.125	4.38E-07	4.37E-07	4.42E-07	4.48E-07	4.54E-07	4.43968E-07	1254147	0.8143
3	150	0.15	4.09E-07	4.09E-07	4.1E-07	4.12E-07	4.12E-07	4.10286E-07	1159000	0.4462
4	175	0.176	3.75E-07	3.75E-07	3.73E-07	3.72E-07	3.73E-07	3.7376E-07	1055819	0.4397
5	200	0.2	3.41E-07	3.41E-07	3.42E-07	3.42E-07	3.43E-07	3.41852E-07	965683.6	0.4327
6	225	0.231	3.15E-07	3.16E-07	3.13E-07	3.13E-07	3.14E-07	3.14332E-07	887943.5	0.4512
7	250	0.25	3.01E-07	2.99E-07	2.99E-07	2.99E-07	2.98E-07	2.99338E-07	845587.6	0.4367
8	275	0.275	2.85E-07	2.85E-07	2.85E-07	2.85E-07	2.84E-07	2.84912E-07	804836.2	0.4222
9	300	0.3	2.7E-07	2.7E-07	2.71E-07	2.71E-07	2.71E-07	2.70782E-07	764920.9	0.4218
10	325	0.324	2.57E-07	2.57E-07	2.56E-07	2.56E-07	2.55E-07	2.56306E-07	724028.2	0.4408
11	350	0.351	2.45E-07	2.44E-07	2.44E-07	2.44E-07	2.43E-07	2.43994E-07	689248.6	0.4284
12	375	0.375	2.33E-07	2.34E-07	2.34E-07	2.34E-07	2.33E-07	2.3382E-07	660508.5	0.4246
13	400	0.4	2.24E-07	2.24E-07	2.24E-07	2.24E-07	2.24E-07	2.23908E-07	632508.5	0.4206
14	425	0.426	2.16E-07	2.16E-07	2.17E-07	2.17E-07	2.17E-07	2.16576E-07	611796.6	0.4178
15	450	0.451	2.11E-07	2.11E-07	2.12E-07	2.12E-07	2.12E-07	2.11448E-07	597310.7	0.4174

16	475	0.476	2.09E-07	2.09E-07	2.09E-07	2.09E-07	2.09E-07	2.0896E-07	590282.5	0.4171
17	500	0.5	2.03E-07	2.03E-07	2.03E-07	2.03E-07	2.03E-07	2.03086E-07	573689.3	0.4205
18	525	0.526	1.98E-07	1.98E-07	1.99E-07	1.98E-07	1.99E-07	1.98456E-07	560610.2	0.4174
19	550	0.55	1.96E-07	1.96E-07	1.96E-07	1.96E-07	1.96E-07	1.95774E-07	553033.9	0.4187
20	575	0.577	1.99E-07	1.9E-07	1.9E-07	1.9E-07	1.9E-07	1.91844E-07	541932.2	1.0262
21	600	0.6	1.85E-07	1.85E-07	1.85E-07	1.85E-07	1.84E-07	1.84536E-07	521288.1	0.4201
22	625	0.625	1.82E-07	1.82E-07	1.82E-07	1.82E-07	1.82E-07	1.82082E-07	514355.9	0.4169
23	650	0.652	1.8E-07	1.81E-07	1.81E-07	1.81E-07	1.81E-07	1.80562E-07	510062.1	0.4229
24	675	0.674	1.8E-07	1.81E-07	1.81E-07	1.81E-07	1.81E-07	1.80708E-07	510474.6	0.4193
25	700	0.698	1.77E-07	1.77E-07	1.77E-07	1.77E-07	1.77E-07	1.77184E-07	500519.8	0.4187
26	725	0.723	1.73E-07	1.73E-07	1.73E-07	1.73E-07	1.73E-07	1.7285E-07	488276.8	0.4235
27	750	0.75	1.7E-07	1.69E-07	1.69E-07	1.69E-07	1.7E-07	1.69484E-07	478768.4	0.4444
28	775	0.779	1.67E-07	1.67E-07	1.67E-07	1.67E-07	1.67E-07	1.66822E-07	471248.6	0.4179
29	800	0.8	1.66E-07	1.66E-07	1.66E-07	1.65E-07	1.65E-07	1.6551E-07	467542.4	0.419
30	825	0.822	1.63E-07	1.63E-07	1.63E-07	1.63E-07	1.63E-07	1.63158E-07	460898.3	0.4187
31	850	0.845	1.63E-07	1.63E-07	1.63E-07	1.63E-07	1.63E-07	1.63094E-07	460716.4	0.4167
32	875	0.87	1.63E-07	1.63E-07	1.63E-07	1.63E-07	1.63E-07	1.62867E-07	460075.7	0.4167
33	900	0.896	1.62E-07	1.62E-07	1.62E-07	1.62E-07	1.62E-07	1.6207E-07	457824.9	0.4172
34	925	0.923	1.62E-07	1.62E-07	1.62E-07	1.62E-07	1.62E-07	1.6186E-07	457231.6	0.4234
35	950	0.952	1.56E-07	1.56E-07	1.56E-07	1.56E-07	1.55E-07	1.55932E-07	440485.9	0.4306
36	975	0.968	1.53E-07	1.53E-07	1.53E-07	1.53E-07	1.52E-07	1.52824E-07	431706.2	0.4262
37	1000	1	1.48E-07	1.48E-07	1.48E-07	1.48E-07	1.48E-07	1.48304E-07	418937.9	0.4199
38	1025	1.017	1.46E-07	1.46E-07	1.46E-07	1.45E-07	1.45E-07	1.45412E-07	410768.4	0.4352
39	1050	1.053	1.41E-07	1.42E-07	1.42E-07	1.42E-07	1.42E-07	1.41768E-07	400474.6	0.4222
40	1075	1.071	1.4E-07	1.4E-07	1.4E-07	1.4E-07	1.4E-07	1.39788E-07	394881.4	0.4197
41	1100	1.091	1.43E-07	1.43E-07	1.43E-07	1.44E-07	1.43E-07	1.4342E-07	405141.2	0.4175
42	1125	1.132	1.35E-07	1.35E-07	1.35E-07	1.35E-07	1.35E-07	1.34852E-07	380937.9	0.4182
43	1150	1.154	1.33E-07	1.33E-07	1.33E-07	1.33E-07	1.33E-07	1.32934E-07	375519.8	0.4181
44	1175	1.177	1.3E-07	1.29E-07	1.29E-07	1.3E-07	1.28E-07	1.2928E-07	365197.7	0.4494
45	1200	1.2	1.28E-07	1.28E-07	1.28E-07	1.28E-07	1.28E-07	1.27884E-07	361254.2	0.4174
46	1225	1.225	1.26E-07	1.26E-07	1.26E-07	1.26E-07	1.26E-07	1.25866E-07	355553.7	0.419
47	1250	1.25	1.27E-07	1.27E-07	1.27E-07	1.27E-07	1.27E-07	1.27258E-07	359485.9	0.4172
48	1275	1.277	1.24E-07	1.24E-07	1.25E-07	1.24E-07	1.25E-07	1.24506E-07	351711.9	0.4173
49	1300	1.304	1.22E-07	1.22E-07	1.22E-07	1.22E-07	1.21E-07	1.21554E-07	343372.9	0.418
50	1325	1.333	1.22E-07	1.22E-07	1.22E-07	1.22E-07	1.22E-07	1.21538E-07	343327.7	0.4169
51	1350	1.364	1.19E-07	1.19E-07	1.19E-07	1.19E-07	1.19E-07	1.18906E-07	335892.7	0.4189
52	1375	1.364	1.23E-07	1.23E-07	1.23E-07	1.22E-07	1.22E-07	1.2271E-07	346638.4	0.434
53	1400	1.395	1.2E-07	1.2E-07	1.2E-07	1.2E-07	1.2E-07	1.20172E-07	339468.9	0.4189
54	1425	1.429	1.16E-07	1.16E-07	1.16E-07	1.16E-07	1.16E-07	1.15958E-07	327565	0.4194
55	1450	1.463	1.14E-07	1.14E-07	1.14E-07	1.14E-07	1.14E-07	1.14272E-07	322802.3	0.4171
56	1475	1.463	1.13E-07	1.12E-07	1.13E-07	1.13E-07	1.13E-07	1.12529E-07	317879.7	0.4171
57	1500	1.5	1.12E-07	1.12E-07	1.12E-07	1.12E-07	1.12E-07	1.11644E-07	315378.5	0.4169
58	1525	1.539	1.1E-07	1.1E-07	1.1E-07	1.1E-07	1.1E-07	1.09818E-07	310220.3	0.4168
59	1550	1.539	1.1E-07	1.1E-07	1.1E-07	1.1E-07	1.1E-07	1.09936E-07	310553.7	0.4168
60	1575	1.579	1.08E-07	1.08E-07	1.1E-07	1.11E-07	1.11E-07	1.09684E-07	309841.8	0.7076

61	1600	1.579	1.1E-07	1.1E-07	1.1E-07	1.1E-07	1.1E-07	1.102E-07	311299.4	0.4168
62	1625	1.622	1.08E-07	1.08E-07	1.08E-07	1.08E-07	1.08E-07	1.08224E-07	305717.5	0.4168
63	1650	1.667	1.07E-07	1.07E-07	1.07E-07	1.07E-07	1.07E-07	1.07048E-07	302395.5	0.4173
64	1675	1.667	1.07E-07	1.07E-07	1.07E-07	1.07E-07	1.07E-07	1.06714E-07	301452	0.4194
65	1700	1.714	1.06E-07	1.06E-07	1.05E-07	1.05E-07	1.05E-07	1.0543E-07	297824.9	0.4916
66	1725	1.714	1E-07	1E-07	1E-07	1E-07	1E-07	1.0042E-07	283672.3	0.4167
67	1750	1.765	9.75E-08	9.75E-08	9.75E-08	9.75E-08	9.76E-08	9.75044E-08	275436.2	0.4171
68	1775	1.765	9.67E-08	9.64E-08	9.65E-08	9.65E-08	9.67E-08	9.6554E-08	272751.4	0.4213
69	1800	1.818	9.5E-08	9.45E-08	9.46E-08	9.46E-08	9.45E-08	9.4653E-08	267381.4	0.4253
70	1825	1.818	9.45E-08	9.47E-08	9.43E-08	9.42E-08	9.42E-08	9.43754E-08	266597.2	0.4276
71	1850	1.875	9.24E-08	9.25E-08	9.26E-08	9.27E-08	9.28E-08	9.25994E-08	261580.2	0.4274
72	1875	1.875	9.25E-08	9.25E-08	9.26E-08	9.28E-08	9.28E-08	9.26188E-08	261635	0.4219
73	1900	1.875	9.29E-08	9.31E-08	9.33E-08	9.33E-08	9.29E-08	9.30198E-08	262767.8	0.4242
74	1925	1.936	9.13E-08	9.15E-08	9.16E-08	9.18E-08	9.18E-08	9.15724E-08	258679.1	0.4263
75	1950	1.936	9.17E-08	9.15E-08	9.14E-08	9.14E-08	9.17E-08	9.1538E-08	258581.9	0.4243
76	1975	2	9.04E-08	9.01E-08	9E-08	9.01E-08	9.02E-08	9.01526E-08	254668.4	0.424
77	2000	2	9.04E-08	9.05E-08	9.07E-08	9.09E-08	9.04E-08	9.0599E-08	255929.4	0.4331

2. Sampel B

No	F (Hz)	F (kHz)	C1 (F)	C2 (F)	C3 (F)	C4 (F)	C5 (F)	C rata-rata (F)	ε	Kr
1	100	0.1	4.36E-07	4.37E-07	4.38E-07	4.38E-07	4.39E-07	4.37488E-07	1235842	0.4262
2	125	0.125	3.83E-07	3.83E-07	3.82E-07	3.83E-07	3.83E-07	3.82814E-07	1081395	0.4213
3	150	0.15	3.43E-07	3.44E-07	3.44E-07	3.44E-07	3.45E-07	3.44062E-07	971926.6	0.4275
4	175	0.176	3.1E-07	3.1E-07	3.1E-07	3.1E-07	3.1E-07	3.1002E-07	875762.7	0.4173
5	200	0.2	2.85E-07	2.85E-07	2.85E-07	2.85E-07	2.84E-07	2.84774E-07	804446.3	0.4216
6	225	0.231	2.56E-07	2.56E-07	2.56E-07	2.56E-07	2.56E-07	2.5585E-07	722740.1	0.4187
7	250	0.25	2.41E-07	2.41E-07	2.41E-07	2.41E-07	2.4E-07	2.40568E-07	679570.6	0.4175
8	275	0.275	2.23E-07	2.24E-07	2.23E-07	2.24E-07	2.24E-07	2.23464E-07	631254.2	0.4183
9	300	0.3	2.09E-07	2.1E-07	2.1E-07	2.1E-07	2.1E-07	2.09944E-07	593062.1	0.4311
10	325	0.324	1.99E-07	1.98E-07	1.98E-07	1.98E-07	1.98E-07	1.9798E-07	559265.5	0.4273
11	350	0.351	1.87E-07	1.87E-07	1.87E-07	1.87E-07	1.87E-07	1.871E-07	528531.1	0.418
12	375	0.375	1.79E-07	1.79E-07	1.79E-07	1.79E-07	1.79E-07	1.78942E-07	505485.9	0.4185
13	400	0.4	1.71E-07	1.7E-07	1.7E-07	1.71E-07	1.71E-07	1.7063E-07	482005.6	0.4211
14	425	0.426	1.64E-07	1.64E-07	1.63E-07	1.63E-07	1.63E-07	1.63532E-07	461954.8	0.4225
15	450	0.451	1.57E-07	1.58E-07	1.58E-07	1.58E-07	1.58E-07	1.57706E-07	445497.2	0.4226
16	475	0.476	1.52E-07	1.51E-07	1.51E-07	1.51E-07	1.52E-07	1.51442E-07	427802.3	0.4195
17	500	0.5	1.44E-07	1.44E-07	1.44E-07	1.44E-07	1.44E-07	1.44316E-07	407672.3	0.4171
18	525	0.526	1.38E-07	1.38E-07	1.38E-07	1.38E-07	1.38E-07	1.38146E-07	390242.9	0.4167
19	550	0.55	1.33E-07	1.33E-07	1.33E-07	1.33E-07	1.33E-07	1.3315E-07	376129.9	0.4167
20	575	0.577	1.28E-07	1.28E-07	1.28E-07	1.28E-07	1.28E-07	1.28102E-07	361870.1	0.4169
21	600	0.6	1.24E-07	1.24E-07	1.24E-07	1.24E-07	1.24E-07	1.2395E-07	350141.2	0.4167
22	625	0.625	1.2E-07	1.2E-07	1.2E-07	1.2E-07	1.2E-07	1.20048E-07	339118.6	0.4169
23	650	0.652	1.16E-07	1.16E-07	1.16E-07	1.16E-07	1.16E-07	1.15814E-07	327158.2	0.4169
24	675	0.674	1.13E-07	1.13E-07	1.13E-07	1.13E-07	1.13E-07	1.12676E-07	318293.8	0.417
25	700	0.698	1.1E-07	1.1E-07	1.1E-07	1.1E-07	1.1E-07	1.0967E-07	309802.3	0.4167

26	725	0.723	1.07E-07	1.07E-07	1.07E-07	1.07E-07	1.07E-07	1.066E-07	301129.9	0.4167
27	750	0.75	1.04E-07	1.04E-07	1.04E-07	1.04E-07	1.04E-07	1.03534E-07	292468.9	0.4168
28	775	0.779	1E-07	1E-07	1E-07	1E-07	1E-07	1.00444E-07	283740.1	0.4167
29	800	0.8	9.84E-08	9.84E-08	9.84E-08	9.84E-08	9.85E-08	9.84418E-08	278084.2	0.4167
30	825	0.822	9.64E-08	9.64E-08	9.64E-08	9.65E-08	9.65E-08	9.64406E-08	272431.1	0.4168
31	850	0.845	9.43E-08	9.43E-08	9.43E-08	9.43E-08	9.43E-08	9.4276E-08	266316.4	0.4167
32	875	0.87	9.22E-08	9.22E-08	9.22E-08	9.22E-08	9.22E-08	9.22374E-08	260557.6	0.4167
33	900	0.896	9.03E-08	9.02E-08	9.03E-08	9.02E-08	9.03E-08	9.02536E-08	254953.7	0.4167
34	925	0.923	8.84E-08	8.84E-08	8.84E-08	8.83E-08	8.83E-08	8.83532E-08	249585.3	0.4171
35	950	0.952	8.62E-08	8.62E-08	8.61E-08	8.61E-08	8.61E-08	8.61328E-08	243313	0.4169
36	975	0.968	8.5E-08	8.5E-08	8.5E-08	8.5E-08	8.5E-08	8.50324E-08	240204.5	0.4167
37	1000	1	8.3E-08	8.3E-08	8.3E-08	8.3E-08	8.3E-08	8.30126E-08	234498.9	0.4167
38	1025	1.017	8.2E-08	8.2E-08	8.2E-08	8.2E-08	8.2E-08	8.2002E-08	231644.1	0.4167
39	1050	1.053	8E-08	8E-08	8E-08	8E-08	8E-08	8.00268E-08	226064.4	0.4167
40	1075	1.071	7.9E-08	7.9E-08	7.9E-08	7.9E-08	7.9E-08	7.90078E-08	223185.9	0.4167
41	1100	1.091	7.79E-08	7.79E-08	7.79E-08	7.79E-08	7.79E-08	7.79092E-08	220082.5	0.4167
42	1125	1.132	7.59E-08	7.59E-08	7.59E-08	7.59E-08	7.59E-08	7.59188E-08	214599.9	0.4167
43	1150	1.154	7.49E-08	7.49E-08	7.49E-08	7.49E-08	7.49E-08	7.48542E-08	211452.5	0.4167
44	1175	1.177	7.39E-08	7.39E-08	7.39E-08	7.39E-08	7.39E-08	7.38874E-08	208721.5	0.4167
45	1200	1.2	7.29E-08	7.28E-08	7.28E-08	7.28E-08	7.26E-08	7.2787E-08	205613	0.4246
46	1225	1.225	7.19E-08	7.18E-08	7.18E-08	7.18E-08	7.18E-08	7.18398E-08	202937.3	0.4167
47	1250	1.25	7.08E-08	7.08E-08	7.08E-08	7.08E-08	7.08E-08	7.08072E-08	200020.3	0.4167
48	1275	1.277	6.98E-08	6.98E-08	6.98E-08	6.98E-08	6.98E-08	6.9826E-08	197248.6	0.4167
49	1300	1.304	6.88E-08	6.88E-08	6.88E-08	6.88E-08	6.88E-08	6.88084E-08	194374	0.4167
50	1325	1.333	6.77E-08	6.77E-08	6.77E-08	6.77E-08	6.77E-08	6.77306E-08	191329.4	0.4167
51	1350	1.364	6.68E-08	6.68E-08	6.68E-08	6.68E-08	6.68E-08	6.67664E-08	188605.6	0.4167
52	1375	1.364	6.67E-08	6.67E-08	6.67E-08	6.67E-08	6.67E-08	6.67282E-08	188497.7	0.4167
53	1400	1.395	6.58E-08	6.58E-08	6.58E-08	6.58E-08	6.58E-08	6.5764E-08	185774	0.4167
54	1425	1.429	6.48E-08	6.48E-08	6.48E-08	6.48E-08	6.48E-08	6.47612E-08	182941.2	0.4167
55	1450	1.463	6.38E-08	6.37E-08	6.37E-08	6.37E-08	6.37E-08	6.3739E-08	180053.7	0.4167
56	1475	1.463	6.37E-08	6.37E-08	6.37E-08	6.37E-08	6.37E-08	6.36942E-08	179927.1	0.4167
57	1500	1.5	6.27E-08	6.27E-08	6.27E-08	6.27E-08	6.27E-08	6.26948E-08	177104	0.4167
58	1525	1.539	6.17E-08	6.17E-08	6.17E-08	6.17E-08	6.17E-08	6.16896E-08	174264.4	0.4167
59	1550	1.539	6.17E-08	6.17E-08	6.17E-08	6.17E-08	6.17E-08	6.17204E-08	174351.4	0.4167
60	1575	1.579	6.07E-08	6.07E-08	6.07E-08	6.07E-08	6.07E-08	6.07026E-08	171476.3	0.4167
61	1600	1.579	6.07E-08	6.07E-08	6.07E-08	6.07E-08	6.07E-08	6.0722E-08	171531.1	0.4167
62	1625	1.622	5.96E-08	5.96E-08	5.96E-08	5.96E-08	5.96E-08	5.96366E-08	168465	0.4167
63	1650	1.667	5.86E-08	5.86E-08	5.86E-08	5.86E-08	5.86E-08	5.85696E-08	165450.8	0.4167
64	1675	1.667	5.86E-08	5.86E-08	5.86E-08	5.86E-08	5.86E-08	5.8584E-08	165491.5	0.4167
65	1700	1.714	5.76E-08	5.76E-08	5.76E-08	5.76E-08	5.76E-08	5.75724E-08	162633.9	0.4167
66	1725	1.714	5.76E-08	5.76E-08	5.76E-08	5.76E-08	5.76E-08	5.75886E-08	162679.7	0.4167
67	1750	1.765	5.58E-08	5.57E-08	5.57E-08	5.57E-08	5.56E-08	5.57096E-08	157371.8	0.419
68	1775	1.765	5.53E-08	5.53E-08	5.53E-08	5.52E-08	5.52E-08	5.52584E-08	156097.2	0.4168
69	1800	1.818	5.41E-08	5.41E-08	5.41E-08	5.41E-08	5.21E-08	5.37234E-08	151761	0.8518
70	1825	1.818	5.41E-08	5.41E-08	5.41E-08	5.41E-08	5.41E-08	5.41264E-08	152899.4	0.4167

71	1850	1.875	5.31E-08	5.31E-08	5.31E-08	5.31E-08	5.31E-08	5.31134E-08	150037.9	0.4167
72	1875	1.875	5.31E-08	5.31E-08	5.31E-08	5.31E-08	5.31E-08	5.31394E-08	150111.3	0.4167
73	1900	1.875	5.32E-08	5.32E-08	5.32E-08	5.32E-08	5.32E-08	5.31666E-08	150188.1	0.4167
74	1925	1.936	5.21E-08	5.22E-08	5.21E-08	5.21E-08	5.22E-08	5.21496E-08	147315.3	0.4167
75	1950	1.936	5.22E-08	5.22E-08	5.22E-08	5.22E-08	5.22E-08	5.21744E-08	147385.3	0.4167
76	1975	2	5.11E-08	5.11E-08	5.12E-08	5.11E-08	5.11E-08	5.11474E-08	144484.2	0.4167
77	2000	2	5.12E-08	5.12E-08	5.12E-08	5.12E-08	5.12E-08	5.11782E-08	144571.2	0.4167

3. Sampel C

No	F (Hz)	F (kHz)	C1 (F)	C2 (F)	C3 (F)	C4 (F)	C5 (F)	C rata-rata (F)	ε	Kr
1	100	0.1	4.78E-07	4.78E-07	4.76E-07	4.74E-07	4.74E-07	4.75884E-07	1344305	0.4619
2	125	0.125	4E-07	4E-07	4E-07	4E-07	3.99E-07	3.99884E-07	1129616	0.4198
3	150	0.15	3.51E-07	3.52E-07	3.51E-07	3.51E-07	3.5E-07	3.51264E-07	992271.2	0.4222
4	175	0.1765	3.13E-07	3.13E-07	3.14E-07	3.14E-07	3.13E-07	3.13406E-07	885327.7	0.427
5	200	0.2	2.87E-07	2.86E-07	2.85E-07	2.84E-07	2.84E-07	2.85254E-07	805802.3	0.4514
6	225	0.2308	2.6E-07	2.59E-07	2.6E-07	2.61E-07	2.61E-07	2.60008E-07	734485.9	0.4351
7	250	0.25	2.47E-07	2.47E-07	2.47E-07	2.48E-07	2.49E-07	2.47706E-07	699734.5	0.4368
8	275	0.2752	2.35E-07	2.35E-07	2.35E-07	2.34E-07	2.34E-07	2.34394E-07	662129.9	0.4299
9	300	0.3	2.23E-07	2.21E-07	2.21E-07	2.2E-07	2.2E-07	2.21122E-07	624638.4	0.4676
10	325	0.3243	2.12E-07	2.12E-07	2.12E-07	2.12E-07	2.12E-07	2.1205E-07	599011.3	0.421
11	350	0.3509	2.02E-07	2.02E-07	2.02E-07	2.01E-07	2.02E-07	2.01936E-07	570440.7	0.4229
12	375	0.375	1.91E-07	1.91E-07	1.91E-07	1.91E-07	1.91E-07	1.91072E-07	539751.4	0.4193
13	400	0.4	1.83E-07	1.83E-07	1.83E-07	1.83E-07	1.83E-07	1.82848E-07	516519.8	0.4178
14	425	0.4255	1.75E-07	1.76E-07	1.75E-07	1.74E-07	1.74E-07	1.74708E-07	493525.4	0.4642
15	450	0.4511	1.66E-07	1.66E-07	1.67E-07	1.67E-07	1.67E-07	1.6672E-07	470960.5	0.4355
16	475	0.4762	1.62E-07	1.62E-07	1.62E-07	1.62E-07	1.62E-07	1.61844E-07	457186.4	0.4312
17	500	0.5	1.54E-07	1.55E-07	1.56E-07	1.56E-07	1.56E-07	1.55522E-07	439327.7	0.521
18	525	0.5263	1.49E-07	1.49E-07	1.5E-07	1.5E-07	1.5E-07	1.49804E-07	423175.1	0.4457
19	550	0.5505	1.46E-07	1.45E-07	1.45E-07	1.45E-07	1.46E-07	1.4527E-07	410367.2	0.4268
20	575	0.5769	1.37E-07	1.37E-07	1.37E-07	1.37E-07	1.37E-07	1.37038E-07	387113	0.4352
21	600	0.6	1.34E-07	1.34E-07	1.34E-07	1.34E-07	1.34E-07	1.33858E-07	378129.9	0.4247
22	625	0.625	1.28E-07	1.28E-07	1.28E-07	1.28E-07	1.28E-07	1.28182E-07	362096	0.4261
23	650	0.6522	1.24E-07	1.22E-07	1.23E-07	1.24E-07	1.24E-07	1.234E-07	348587.6	0.5481
24	675	0.6742	1.19E-07	1.19E-07	1.19E-07	1.19E-07	1.19E-07	1.19052E-07	336305.1	0.4691
25	700	0.6977	1.16E-07	1.16E-07	1.16E-07	1.16E-07	1.17E-07	1.1616E-07	328135.6	0.4255
26	725	0.7229	1.12E-07	1.11E-07	1.11E-07	1.12E-07	1.13E-07	1.11678E-07	315474.6	0.4941
27	750	0.75	1.09E-07	1.08E-07	1.08E-07	1.08E-07	1.08E-07	1.08308E-07	305954.8	0.4332
28	775	0.7792	9.98E-08	1E-07	1E-07	1E-07	9.98E-08	1.00015E-07	282529.4	0.426
29	800	0.8	9.77E-08	9.79E-08	9.8E-08	9.77E-08	9.74E-08	9.77278E-08	276067.2	0.4281
30	825	0.8219	9.59E-08	9.57E-08	9.6E-08	9.57E-08	9.58E-08	9.57968E-08	270612.4	0.4203
31	850	0.8451	9.09E-08	9.12E-08	9.12E-08	9.12E-08	9.09E-08	9.10776E-08	257281.4	0.423
32	875	0.8696	8.69E-08	8.67E-08	8.65E-08	8.67E-08	8.72E-08	8.67924E-08	245176.3	0.4436
33	900	0.8955	8.3E-08	8.27E-08	8.26E-08	8.28E-08	8.27E-08	8.27726E-08	233820.9	0.4243
34	925	0.9231	7.88E-08	7.86E-08	7.89E-08	7.89E-08	7.89E-08	7.88344E-08	222696	0.4241
35	950	0.9524	7.54E-08	7.55E-08	7.54E-08	7.53E-08	7.53E-08	7.5387E-08	212957.6	0.4217

36	975	0.9678	7.29E-08	7.3E-08	7.29E-08	7.3E-08	7.29E-08	7.2957E-08	206093.2	0.4174
37	1000	1	7.05E-08	7.03E-08	6.98E-08	6.93E-08	6.92E-08	6.98264E-08	197249.7	0.566
38	1025	1.017	6.9E-08	6.92E-08	6.93E-08	6.92E-08	6.88E-08	6.9117E-08	195245.8	0.4317
39	1050	1.0526	6.66E-08	6.56E-08	6.65E-08	6.66E-08	6.67E-08	6.63938E-08	187553.1	0.509
40	1075	1.0714	6.49E-08	6.51E-08	6.46E-08	6.43E-08	6.45E-08	6.46714E-08	182687.6	0.468
41	1100	1.0909	6.37E-08	6.34E-08	6.38E-08	6.39E-08	6.38E-08	6.36916E-08	179919.8	0.4388
42	1125	1.1321	6.14E-08	6.15E-08	6.14E-08	6.15E-08	6.14E-08	6.14406E-08	173561	0.4184
43	1150	1.1539	6.03E-08	6.03E-08	6.03E-08	6.03E-08	6.02E-08	6.02776E-08	170275.7	0.4178
44	1175	1.1765	5.93E-08	5.93E-08	5.93E-08	5.93E-08	5.93E-08	5.92928E-08	167493.8	0.4175
45	1200	1.2	5.79E-08	5.79E-08	5.81E-08	5.81E-08	5.82E-08	5.80198E-08	163897.7	0.4307
46	1225	1.2245	5.32E-08	5.31E-08	5.31E-08	5.31E-08	5.31E-08	5.31266E-08	150075.1	0.4175
47	1250	1.25	5.17E-08	5.17E-08	5.17E-08	5.17E-08	5.18E-08	5.17448E-08	146171.8	0.4167
48	1275	1.2766	5.1E-08	5.1E-08	5.1E-08	5.1E-08	5.1E-08	5.09964E-08	144057.6	0.4171
49	1300	1.3044	5.21E-08	5.19E-08	5.17E-08	5.16E-08	5.15E-08	5.17782E-08	146266.1	0.4648
50	1325	1.3333	5.03E-08	5.02E-08	5.02E-08	5.02E-08	5.02E-08	5.0217E-08	141855.9	0.4171
51	1350	1.3636	4.89E-08	4.9E-08	4.89E-08	4.9E-08	4.89E-08	4.8946E-08	138265.5	0.4169
52	1375	1.3636	4.82E-08	4.82E-08	4.82E-08	4.82E-08	4.82E-08	4.81916E-08	136134.5	0.417
53	1400	1.3954	4.76E-08	4.75E-08	4.75E-08	4.75E-08	4.75E-08	4.75448E-08	134307.3	0.4168
54	1425	1.4286	4.64E-08	4.64E-08	4.64E-08	4.64E-08	4.64E-08	4.64108E-08	131104	0.4168
55	1450	1.4634	4.58E-08	4.58E-08	4.58E-08	4.58E-08	4.58E-08	4.58302E-08	129463.8	0.4167
56	1475	1.4634	4.54E-08	4.54E-08	4.54E-08	4.54E-08	4.54E-08	4.53658E-08	128152	0.4168
57	1500	1.5	4.5E-08	4.49E-08	4.49E-08	4.49E-08	4.49E-08	4.49262E-08	126910.2	0.4173
58	1525	1.5385	4.43E-08	4.43E-08	4.43E-08	4.43E-08	4.43E-08	4.43046E-08	125154.2	0.4168
59	1550	1.5385	4.38E-08	4.38E-08	4.38E-08	4.38E-08	4.38E-08	4.3791E-08	123703.4	0.4172
60	1575	1.579	4.32E-08	4.32E-08	4.32E-08	4.32E-08	4.32E-08	4.3204E-08	122045.2	0.4167
61	1600	1.579	4.26E-08	4.26E-08	4.26E-08	4.26E-08	4.26E-08	4.26248E-08	120409	0.4168
62	1625	1.6216	4.25E-08	4.25E-08	4.25E-08	4.25E-08	4.25E-08	4.2473E-08	119980.2	0.4169
63	1650	1.6667	4.2E-08	4.2E-08	4.2E-08	4.2E-08	4.2E-08	4.19906E-08	118617.5	0.417
64	1675	1.6667	4.21E-08	4.21E-08	4.22E-08	4.22E-08	4.22E-08	4.2157E-08	119087.6	0.4193
65	1700	1.7143	4.09E-08	4.09E-08	4.09E-08	4.09E-08	4.09E-08	4.0899E-08	115533.9	0.4167
66	1725	1.7143	4.06E-08	4.06E-08	4.07E-08	4.07E-08	4.09E-08	4.06692E-08	114884.7	0.4414
67	1750	1.7647	4.02E-08	4.03E-08	4.03E-08	4.03E-08	4.03E-08	4.0316E-08	113887	0.42
68	1775	1.7647	4.04E-08	4.04E-08	4.04E-08	4.04E-08	4.04E-08	4.0367E-08	114031.1	0.4168
69	1800	1.8182	3.98E-08	4.11E-08	4.11E-08	4.11E-08	4.11E-08	4.07992E-08	115252	0.7579
70	1825	1.8182	4.05E-08	4.05E-08	4.05E-08	4.05E-08	4.05E-08	4.04844E-08	114362.7	0.4169
71	1850	1.875	4.07E-08	4.07E-08	4.07E-08	4.07E-08	4.07E-08	4.0741E-08	115087.6	0.4167
72	1875	1.875	4.01E-08	4.01E-08	4.01E-08	4.01E-08	4.01E-08	4.00744E-08	113204.5	0.4172
73	1900	1.875	4.02E-08	4.02E-08	4.02E-08	4.02E-08	4.02E-08	4.0161E-08	113449.2	0.4167
74	1925	1.9355	3.94E-08	3.94E-08	3.94E-08	3.94E-08	3.94E-08	3.94108E-08	111329.9	0.4168
75	1950	1.9355	3.89E-08	3.89E-08	3.88E-08	3.88E-08	3.89E-08	3.88544E-08	109758.2	0.417
76	1975	2	3.9E-08	3.9E-08	3.9E-08	3.9E-08	3.9E-08	3.90204E-08	110227.1	0.4172
77	2000	2	3.84E-08	3.84E-08	3.84E-08	3.84E-08	3.84E-08	3.8439E-08	108584.7	0.4167

4. Sampel D

No	F (Hz)	F (kHz)	C1 (F)	C2 (F)	C3 (F)	C4 (F)	C5 (F)	Crata-rata (F)	ε	Kr
1	100	0.1	4.25E-07	4.25E-07	4.24E-07	4.24E-07	4.23E-07	4.24E-16	1197740	0.4248
2	125	0.125	3.49E-07	3.48E-07	3.48E-07	3.48E-07	3.48E-07	3.48152E-16	983480.2	0.4187
3	150	0.15	2.95E-07	2.95E-07	2.95E-07	2.95E-07	2.95E-07	2.94826E-16	832841.8	0.4171
4	175	0.1765	2.56E-07	2.56E-07	2.56E-07	2.56E-07	2.57E-07	2.56168E-16	723638.4	0.4272
5	200	0.2	2.36E-07	2.36E-07	2.36E-07	2.36E-07	2.36E-07	2.35936E-16	666485.9	0.4167
6	225	0.2308	2.11E-07	2.11E-07	2.11E-07	2.11E-07	2.11E-07	2.1053E-16	594717.5	0.4173
7	250	0.25	1.99E-07	1.99E-07	1.99E-07	1.99E-07	1.99E-07	1.98994E-16	562129.9	0.4215
8	275	0.2752	1.85E-07	1.86E-07	1.86E-07	1.86E-07	1.86E-07	1.86038E-16	525531.1	0.4314
9	300	0.3	1.72E-07	1.73E-07	1.72E-07	1.72E-07	1.72E-07	1.72372E-16	486926.6	0.4186
10	325	0.3243	1.63E-07	1.63E-07	1.62E-07	1.63E-07	1.63E-07	1.62692E-16	459581.9	0.4213
11	350	0.3509	1.53E-07	1.54E-07	1.53E-07	1.53E-07	1.53E-07	1.53356E-16	433209	0.4234
12	375	0.375	1.47E-07	1.46E-07	1.46E-07	1.46E-07	1.45E-07	1.45996E-16	412418.1	0.4444
13	400	0.4	1.39E-07	1.4E-07	1.4E-07	1.4E-07	1.4E-07	1.3992E-16	395254.2	0.4392
14	425	0.4255	1.36E-07	1.36E-07	1.35E-07	1.35E-07	1.35E-07	1.35416E-16	382531.1	0.4476
15	450	0.4511	1.3E-07	1.29E-07	1.29E-07	1.29E-07	1.29E-07	1.294E-16	365536.7	0.4208
16	475	0.4762	1.25E-07	1.25E-07	1.25E-07	1.25E-07	1.25E-07	1.24672E-16	352180.8	0.4171
17	500	0.5	1.2E-07	1.2E-07	1.2E-07	1.2E-07	1.2E-07	1.20202E-16	339553.7	0.4168
18	525	0.5263	1.19E-07	1.18E-07	1.19E-07	1.19E-07	1.19E-07	1.18924E-16	335943.5	0.4381
19	550	0.5505	1.16E-07	1.16E-07	1.16E-07	1.17E-07	1.17E-07	1.16428E-16	328892.7	0.4351
20	575	0.5769	1.14E-07	1.14E-07	1.14E-07	1.14E-07	1.14E-07	1.13886E-16	321711.9	0.4178
21	600	0.6	1.08E-07	1.08E-07	1.08E-07	1.07E-07	1.07E-07	1.07824E-16	304587.6	0.5111
22	625	0.625	1.06E-07	1.06E-07	1.07E-07	1.07E-07	1.07E-07	1.0656E-16	301016.9	0.4199
23	650	0.6522	1.04E-07	1.04E-07	1.04E-07	1.05E-07	1.04E-07	1.04056E-16	293943.5	0.4904
24	675	0.6742	9.96E-08	1.01E-07	1E-07	1E-07	1E-07	1.00142E-16	282885.9	0.4554
25	700	0.6977	9.93E-08	9.93E-08	9.94E-08	9.92E-08	9.93E-08	9.93282E-17	280588.1	0.4178
26	725	0.7229	9.79E-08	9.74E-08	9.74E-08	9.74E-08	9.73E-08	9.74856E-17	275383.1	0.4304
27	750	0.75	9.37E-08	9.37E-08	9.38E-08	9.4E-08	9.4E-08	9.38352E-17	265071.2	0.4209
28	775	0.7792	9.08E-08	9.05E-08	9.02E-08	9.06E-08	9.08E-08	9.05706E-17	255849.2	0.4321
29	800	0.8	8.54E-08	8.55E-08	8.54E-08	8.56E-08	8.56E-08	8.54836E-17	241479.1	0.4189
30	825	0.8219	8.39E-08	8.38E-08	8.38E-08	8.38E-08	8.39E-08	8.38478E-17	236858.2	0.419
31	850	0.8451	8.2E-08	8.21E-08	8.21E-08	8.21E-08	8.17E-08	8.20182E-17	231689.8	0.4296
32	875	0.8696	8E-08	8E-08	8E-08	7.99E-08	7.99E-08	7.99692E-17	225901.7	0.4183
33	900	0.8955	7.75E-08	7.77E-08	7.78E-08	7.78E-08	7.78E-08	7.7731E-17	219579.1	0.4256
34	925	0.9231	7.54E-08	7.54E-08	7.54E-08	7.55E-08	7.54E-08	7.54296E-17	213078	0.4171
35	950	0.9524	7.29E-08	7.29E-08	7.29E-08	7.27E-08	7.26E-08	7.28158E-17	205694.4	0.428
36	975	0.9678	7.08E-08	7.08E-08	7.07E-08	7.08E-08	7.07E-08	7.07552E-17	199873.4	0.4169
37	1000	1	6.97E-08	6.97E-08	6.96E-08	6.94E-08	6.93E-08	6.95286E-17	196408.5	0.4324
38	1025	1.017	6.78E-08	6.78E-08	6.77E-08	6.77E-08	6.77E-08	6.77408E-17	191358.2	0.4181
39	1050	1.0526	6.57E-08	6.58E-08	6.57E-08	6.55E-08	6.55E-08	6.56158E-17	185355.4	0.4247
40	1075	1.0714	6.48E-08	6.48E-08	6.49E-08	6.49E-08	6.46E-08	6.4799E-17	183048	0.423
41	1100	1.0909	6.4E-08	6.39E-08	6.41E-08	6.4E-08	6.39E-08	6.3998E-17	180785.3	0.4234
42	1125	1.1321	6.24E-08	6.24E-08	6.23E-08	6.22E-08	6.22E-08	6.23196E-17	176044.1	0.4226
43	1150	1.1539	6.15E-08	6.13E-08	6.12E-08	6.12E-08	6.11E-08	6.12676E-17	173072.3	0.4292
44	1175	1.1765	6.05E-08	6.05E-08	6.05E-08	6.04E-08	6.05E-08	6.04732E-17	170828.2	0.4181
45	1200	1.2	5.97E-08	5.95E-08	5.96E-08	5.97E-08	5.97E-08	5.96384E-17	168470.1	0.42

46	1225	1.2245	5.87E-08	5.87E-08	5.87E-08	5.87E-08	5.87E-08	5.87E-08	5.87146E-17	165860.5	0.4168
47	1250	1.25	5.83E-08	5.82E-08	5.82E-08	5.81E-08	5.8E-08	5.8E-08	5.81514E-17	164269.5	0.4289
48	1275	1.2766	5.72E-08	5.73E-08	5.74E-08	5.73E-08	5.73E-08	5.73E-08	5.7287E-17	161827.7	0.4222
49	1300	1.3044	5.62E-08	5.61E-08	5.61E-08	5.61E-08	5.61E-08	5.61E-08	5.61274E-17	158552	0.4178
50	1325	1.3333	5.56E-08	5.56E-08	5.56E-08	5.56E-08	5.56E-08	5.56E-08	5.55886E-17	157029.9	0.4168
51	1350	1.3636	5.48E-08	5.49E-08	5.49E-08	5.49E-08	5.49E-08	5.49E-08	5.48466E-17	154933.9	0.4182
52	1375	1.3636	5.48E-08	5.47E-08	5.48E-08	5.48E-08	5.48E-08	5.48E-08	5.4775E-17	154731.6	0.4179
53	1400	1.3954	5.4E-08	5.4E-08	5.4E-08	5.41E-08	5.4E-08	5.4E-08	5.4038E-17	152649.7	0.417
54	1425	1.4286	5.01E-08	5.01E-08	5.01E-08	5.01E-08	5.01E-08	5.01E-08	5.00528E-17	141392.1	0.4167
55	1450	1.4634	4.62E-08	4.63E-08	4.64E-08	4.64E-08	4.63E-08	4.63E-08	4.63094E-17	130817.5	0.4218
56	1475	1.4634	4.68E-08	4.68E-08	4.68E-08	4.68E-08	4.68E-08	4.68E-08	4.68084E-17	132227.1	0.4171
57	1500	1.5	4.62E-08	4.62E-08	4.61E-08	4.61E-08	4.62E-08	4.61534E-17	130376.8	0.4187	
58	1525	1.5385	4.54E-08	4.55E-08	4.54E-08	4.54E-08	4.55E-08	4.54312E-17	128336.7	0.4183	
59	1550	1.5385	4.51E-08	4.5E-08	4.49E-08	4.48E-08	4.47E-08	4.4897E-17	126827.7	0.4441	
60	1575	1.579	4.36E-08	4.35E-08	4.35E-08	4.35E-08	4.35E-08	4.3516E-17	122926.6	0.4188	
61	1600	1.579	4.3E-08	4.31E-08	4.31E-08	4.31E-08	4.31E-08	4.30966E-17	121741.8	0.4187	
62	1625	1.6216	4.23E-08	4.23E-08	4.23E-08	4.23E-08	4.23E-08	4.22736E-17	119416.9	0.4168	
63	1650	1.6667	4.13E-08	4.13E-08	4.12E-08	4.11E-08	4.12E-08	4.12066E-17	116402.8	0.4207	
64	1675	1.6667	4.09E-08	4.08E-08	4.09E-08	4.08E-08	4.08E-08	4.08504E-17	115396.6	0.4171	
65	1700	1.7143	3.99E-08	4.0E-08	3.99E-08	3.99E-08	3.99E-08	3.99268E-17	112787.6	0.4175	
66	1725	1.7143	3.96E-08	3.96E-08	3.96E-08	3.96E-08	3.96E-08	3.96104E-17	111893.8	0.4173	
67	1750	1.7647	3.85E-08	3.85E-08	3.84E-08	3.84E-08	3.85E-08	3.84584E-17	108639.5	0.4185	
68	1775	1.7647	3.81E-08	3.81E-08	3.8E-08	3.8E-08	3.8E-08	3.80294E-17	107427.7	0.424	
69	1800	1.8182	3.71E-08	3.71E-08	3.72E-08	3.72E-08	3.72E-08	3.7159E-17	104968.9	0.4177	
70	1825	1.8182	3.77E-08	3.77E-08	3.77E-08	3.78E-08	3.78E-08	3.77112E-17	106531.6	0.4229	
71	1850	1.875	3.79E-08	3.8E-08	3.8E-08	3.8E-08	3.79E-08	3.79738E-17	107270.6	0.4196	
72	1875	1.875	3.87E-08	3.87E-08	3.87E-08	3.87E-08	3.88E-08	3.87068E-17	109341.2	0.4188	
73	1900	1.875	3.95E-08	3.96E-08	3.96E-08	3.96E-08	3.96E-08	3.95708E-17	111781.9	0.4173	
74	1925	1.9355	3.92E-08	3.92E-08	3.92E-08	3.92E-08	3.93E-08	3.92202E-17	110791.5	0.4177	
75	1950	1.9355	3.9E-08	3.9E-08	2.99E-08	2.99E-08	2.99E-08	2.99506E-17	84606.21	0.4217	
76	1975	2	2.95E-08	2.95E-08	2.94E-08	2.94E-08	2.94E-08	2.94424E-17	83170.62	0.4173	
77	2000	2	2.87E-08	2.87E-08	2.87E-08	2.87E-08	2.87E-08	2.87052E-17	81088.14	0.4169	

d. 30 mL

1. Sampel A

No	F (Hz)	F (kHz)	C1 (F)	C2 (F)	C3 (F)	C4 (F)	C5 (F)	C rata-rata (F)	ε	Kr
1	100	0.1	2.1E-07	2.09E-07	2.08E-07	2.08E-07	2.08E-07	2.08482E-07	588932.2	0.491664
2	125	0.125	1.84E-07	1.85E-07	1.87E-07	1.88E-07	1.88E-07	1.86576E-07	527050.8	0.630944
3	150	0.15	1.64E-07	1.64E-07	1.64E-07	1.63E-07	1.63E-07	1.63648E-07	462282.5	0.451453
4	175	0.1765	1.43E-07	1.43E-07	1.43E-07	1.43E-07	1.43E-07	1.43112E-07	404271.2	0.425694
5	200	0.2	1.22E-07	1.23E-07	1.24E-07	1.26E-07	1.27E-07	1.2453E-07	351779.7	0.940137
6	225	0.2308	1.11E-07	1.11E-07	1.11E-07	1.1E-07	1.1E-07	1.10624E-07	312497.2	0.427714
7	250	0.25	1.05E-07	1.05E-07	1.05E-07	1.07E-07	1.08E-07	1.0598E-07	299378.5	0.667692
8	275	0.2752	1.01E-07	1.01E-07	1.01E-07	1.02E-07	1.01E-07	1.01404E-07	286452	0.418095
9	300	0.3	9.5E-08	9.49E-08	9.49E-08	9.49E-08	9.5E-08	9.4922E-08	268141.2	0.41767
10	325	0.3243	8.98E-08	8.99E-08	8.99E-08	8.99E-08	8.99E-08	8.9883E-08	253906.8	0.417328

11	350	0.3509	8.4E-08	8.39E-08	8.38E-08	8.39E-08	8.39E-08	8.39174E-08	237054.8	0.418417
12	375	0.375	7.91E-08	7.91E-08	7.9E-08	7.9E-08	7.9E-08	7.90436E-08	223287	0.41812
13	400	0.4	7.51E-08	7.51E-08	7.51E-08	7.52E-08	7.51E-08	7.51464E-08	212278	0.416965
14	425	0.4255	7.19E-08	7.19E-08	7.19E-08	7.19E-08	7.19E-08	7.19266E-08	203182.5	0.41678
15	450	0.4511	6.92E-08	6.9E-08	6.9E-08	6.87E-08	6.9E-08	6.89754E-08	194845.8	0.433483
16	475	0.4762	6.62E-08	6.62E-08	6.62E-08	6.62E-08	6.61E-08	6.61938E-08	186988.1	0.418177
17	500	0.5	6.38E-08	6.38E-08	6.37E-08	6.37E-08	6.37E-08	6.37426E-08	180063.8	0.418132
18	525	0.5263	6.17E-08	6.16E-08	6.16E-08	6.16E-08	6.16E-08	6.16298E-08	174095.5	0.416906
19	550	0.5505	5.96E-08	5.96E-08	5.96E-08	5.96E-08	5.97E-08	5.96418E-08	168479.7	0.417108
20	575	0.5769	5.74E-08	5.75E-08	5.75E-08	5.75E-08	5.76E-08	5.75006E-08	162431.1	0.418806
21	600	0.6	5.56E-08	5.57E-08	5.57E-08	5.57E-08	5.57E-08	5.56854E-08	157303.4	0.418347
22	625	0.625	5.35E-08	5.35E-08	5.35E-08	5.35E-08	5.35E-08	5.35E-08	151129.9	0.417132
23	650	0.6522	5.27E-08	5.27E-08	5.27E-08	5.26E-08	5.26E-08	5.26586E-08	148753.1	0.417962
24	675	0.6742	5.13E-08	5.13E-08	5.12E-08	5.12E-08	5.13E-08	5.12466E-08	144764.4	0.417213
25	700	0.6977	5E-08	5E-08	5E-08	4.99E-08	4.99E-08	4.99376E-08	141066.7	0.418405
26	725	0.7229	4.86E-08	4.84E-08	4.84E-08	4.84E-08	4.84E-08	4.8445E-08	136850.3	0.423833
27	750	0.75	4.7E-08	4.69E-08	4.7E-08	4.69E-08	4.7E-08	4.69634E-08	132665	0.417513
28	775	0.7792	4.54E-08	4.53E-08	4.53E-08	4.53E-08	4.54E-08	4.53438E-08	128089.8	0.41691
29	800	0.8	4.43E-08	4.42E-08	4.42E-08	4.42E-08	4.42E-08	4.42156E-08	124902.8	0.417924
30	825	0.8219	4.32E-08	4.34E-08	4.34E-08	4.33E-08	4.33E-08	4.3297E-08	122307.9	0.423675
31	850	0.8451	4.23E-08	4.22E-08	4.22E-08	4.22E-08	4.22E-08	4.2236E-08	119310.7	0.417329
32	875	0.8696	4.07E-08	4.07E-08	4.07E-08	4.07E-08	4.07E-08	4.07342E-08	115068.4	0.416873
33	900	0.8955	3.95E-08	3.95E-08	3.94E-08	3.95E-08	3.95E-08	3.95144E-08	111622.6	0.419176
34	925	0.9231	3.84E-08	3.84E-08	3.84E-08	3.84E-08	3.84E-08	3.84204E-08	108532.2	0.416748
35	950	0.9524	3.73E-08	3.73E-08	3.73E-08	3.73E-08	3.73E-08	3.7317E-08	105415.3	0.416826
36	975	0.9678	3.69E-08	3.69E-08	3.69E-08	3.69E-08	3.69E-08	3.68824E-08	104187.6	0.416766
37	1000	1	3.59E-08	3.59E-08	3.59E-08	3.58E-08	3.58E-08	3.58498E-08	101270.6	0.418115
38	1025	1.017	3.53E-08	3.53E-08	3.53E-08	3.53E-08	3.52E-08	3.52638E-08	99615.25	0.41699
39	1050	1.0526	3.43E-08	3.43E-08	3.43E-08	3.43E-08	3.43E-08	3.42898E-08	96663.84	0.416787
40	1075	1.0714	3.37E-08	3.37E-08	3.37E-08	3.37E-08	3.37E-08	3.36848E-08	95154.8	0.416941
41	1100	1.0909	3.32E-08	3.32E-08	3.33E-08	3.32E-08	3.33E-08	3.32544E-08	93938.98	0.417062
42	1125	1.1321	3.22E-08	3.22E-08	3.22E-08	3.22E-08	3.22E-08	3.22272E-08	91037.29	0.416862
43	1150	1.1539	3.16E-08	3.16E-08	3.16E-08	3.16E-08	3.17E-08	3.16456E-08	89394.35	0.416745
44	1175	1.1765	3.11E-08	3.11E-08	3.11E-08	3.11E-08	3.11E-08	3.11034E-08	87862.71	0.416744
45	1200	1.2	3.06E-08	3.07E-08	3.07E-08	3.07E-08	3.07E-08	3.06516E-08	86586.44	0.416729
46	1225	1.2245	3.02E-08	3.02E-08	3.02E-08	3.02E-08	3.02E-08	3.0189E-08	85279.66	0.41676
47	1250	1.25	2.97E-08	2.97E-08	2.96E-08	2.97E-08	2.97E-08	2.96606E-08	83787.01	0.41694
48	1275	1.2766	2.93E-08	2.93E-08	2.93E-08	2.94E-08	2.94E-08	2.93326E-08	82860.45	0.425469
49	1300	1.3044	2.89E-08	2.89E-08	2.89E-08	2.89E-08	2.89E-08	2.88924E-08	81616.95	0.416702
50	1325	1.3333	2.83E-08	2.83E-08	2.83E-08	2.83E-08	2.83E-08	2.82856E-08	79902.82	0.417128
51	1350	1.3636	2.78E-08	2.78E-08	2.78E-08	2.78E-08	2.78E-08	2.7816E-08	78576.27	0.416907
52	1375	1.3636	2.77E-08	2.77E-08	2.77E-08	2.77E-08	2.77E-08	2.7699E-08	78245.76	0.416865
53	1400	1.3954	2.72E-08	2.72E-08	2.72E-08	2.72E-08	2.72E-08	2.71898E-08	76807.34	0.41717
54	1425	1.4286	2.68E-08	2.68E-08	2.68E-08	2.68E-08	2.68E-08	2.6812E-08	75740.11	0.416723
55	1450	1.4634	2.63E-08	2.62E-08	2.62E-08	2.62E-08	2.62E-08	2.62374E-08	74116.95	0.417293
56	1475	1.4634	2.63E-08	2.63E-08	2.63E-08	2.62E-08	2.62E-08	2.62564E-08	74170.62	0.418554
57	1500	1.5	2.57E-08	2.57E-08	2.57E-08	2.57E-08	2.57E-08	2.57088E-08	72623.73	0.41688
58	1525	1.5385	2.52E-08	2.52E-08	2.52E-08	2.52E-08	2.52E-08	2.51952E-08	71172.88	0.417257
59	1550	1.5385	2.52E-08	2.52E-08	2.52E-08	2.52E-08	2.52E-08	2.52034E-08	71196.05	0.416777
60	1575	1.579	2.46E-08	2.46E-08	2.46E-08	2.47E-08	2.47E-08	2.46534E-08	69642.37	0.417063

61	1600	1.579	2.46E-08	2.46E-08	2.46E-08	2.46E-08	2.46E-08	2.46166E-08	69538.42	0.420017
62	1625	1.6216	2.41E-08	2.41E-08	2.42E-08	2.41E-08	2.41E-08	2.41414E-08	68196.05	0.417055
63	1650	1.6667	2.37E-08	2.36E-08	2.36E-08	2.36E-08	2.37E-08	2.36498E-08	66807.34	0.416704
64	1675	1.6667	2.36E-08	2.36E-08	2.36E-08	2.36E-08	2.36E-08	2.36308E-08	66753.67	0.417041
65	1700	1.7143	2.31E-08	2.31E-08	2.31E-08	2.31E-08	2.31E-08	2.31322E-08	65345.2	0.416798
66	1725	1.7143	2.31E-08	2.31E-08	2.31E-08	2.31E-08	2.32E-08	2.31246E-08	65323.73	0.417894
67	1750	1.7647	2.27E-08	2.27E-08	2.27E-08	2.27E-08	2.27E-08	2.26906E-08	64097.74	0.416747
68	1775	1.7647	2.26E-08	2.26E-08	2.26E-08	2.26E-08	2.26E-08	2.25968E-08	63832.77	0.417118
69	1800	1.8182	2.21E-08	2.21E-08	2.21E-08	2.21E-08	2.21E-08	2.20824E-08	62379.66	0.416722
70	1825	1.8182	2.21E-08	2.21E-08	2.21E-08	2.21E-08	2.21E-08	2.2084E-08	62384.18	0.416699
71	1850	1.875	2.15E-08	2.15E-08	2.15E-08	2.15E-08	2.15E-08	2.15354E-08	60834.46	0.417035
72	1875	1.875	2.14E-08	2.15E-08	2.13E-08	2.14E-08	2.14E-08	2.1373E-08	60375.71	0.427662
73	1900	1.875	2.12E-08	2.12E-08	2.12E-08	2.12E-08	2.12E-08	2.11884E-08	59854.24	0.416674
74	1925	1.9355	2.11E-08	2.11E-08	2.11E-08	2.11E-08	2.11E-08	2.11234E-08	59670.62	0.416706
75	1950	1.9355	2.11E-08	2.11E-08	2.11E-08	2.11E-08	2.11E-08	2.10882E-08	59571.19	0.416676
76	1975	2	2.1E-08	2.1E-08	2.1E-08	2E-08	2E-08	2.06198E-08	58248.02	1.252264
77	2000	2	2.09E-08	2.09E-08	2.09E-08	2.09E-08	2.09E-08	2.08802E-08	58983.62	0.417179

2. Sampel B

No	F (Hz)	F (kHz)	C1 (F)	C2 (F)	C3 (F)	C4 (F)	C5 (F)	Crata-rata (F)	ϵ	Kr
1	100	0.1	2.21E-07	2.01E-07	2.2E-07	2.19E-07	2.19E-07	2.15964E-07	610067.8	1.838404
2	125	0.125	1.68E-07	1.68E-07	1.67E-07	1.67E-07	1.67E-07	1.67384E-07	472836.2	0.423037
3	150	0.15	1.38E-07	1.38E-07	1.38E-07	1.38E-07	1.38E-07	1.37684E-07	388937.9	0.41753
4	175	0.1765	1.17E-07	1.17E-07	1.17E-07	1.17E-07	1.17E-07	1.16806E-07	329960.5	0.417919
5	200	0.2	1.03E-07	1.03E-07	1.03E-07	1.03E-07	1.03E-07	1.02846E-07	290525.4	0.418033
6	225	0.2308	8.97E-08	8.97E-08	8.97E-08	8.96E-08	8.96E-08	8.96656E-08	253292.7	0.417535
7	250	0.25	8.31E-08	8.29E-08	8.3E-08	8.3E-08	8.28E-08	8.29546E-08	234335	0.419264
8	275	0.2752	7.58E-08	7.58E-08	7.58E-08	7.58E-08	7.58E-08	7.5785E-08	214081.9	0.416933
9	300	0.3	6.99E-08	6.99E-08	6.99E-08	6.99E-08	6.98E-08	6.98722E-08	197379.1	0.41701
10	325	0.3243	6.5E-08	6.49E-08	6.49E-08	6.49E-08	6.49E-08	6.4927E-08	183409.6	0.41692
11	350	0.3509	6.04E-08	6.03E-08	6.03E-08	6.03E-08	6.03E-08	6.03204E-08	170396.6	0.417223
12	375	0.375	5.67E-08	5.68E-08	5.67E-08	5.67E-08	5.67E-08	5.67366E-08	160272.9	0.416812
13	400	0.4	5.36E-08	5.36E-08	5.36E-08	5.36E-08	5.36E-08	5.3598E-08	151406.8	0.4168
14	425	0.4255	5.08E-08	5.08E-08	5.08E-08	5.07E-08	5.08E-08	5.0757E-08	143381.4	0.416743
15	450	0.4511	4.83E-08	4.83E-08	4.83E-08	4.83E-08	4.83E-08	4.83048E-08	136454.2	0.416775
16	475	0.4762	4.62E-08	4.61E-08	4.61E-08	4.61E-08	4.61E-08	4.6139E-08	130336.2	0.416877
17	500	0.5	4.43E-08	4.43E-08	4.43E-08	4.43E-08	4.43E-08	4.42834E-08	125094.4	0.416737
18	525	0.5263	4.25E-08	4.25E-08	4.25E-08	4.25E-08	4.25E-08	4.25194E-08	120111.3	0.416842
19	550	0.5505	4.11E-08	4.11E-08	4.11E-08	4.11E-08	4.11E-08	4.11106E-08	116131.6	0.417237
20	575	0.5769	3.96E-08	3.96E-08	3.97E-08	3.97E-08	3.97E-08	3.96498E-08	112005.1	0.416759
21	600	0.6	3.86E-08	3.86E-08	3.86E-08	3.86E-08	3.86E-08	3.85602E-08	108927.1	0.416749
22	625	0.625	3.73E-08	3.73E-08	3.73E-08	3.73E-08	3.74E-08	3.73388E-08	105476.8	0.416889
23	650	0.6522	3.62E-08	3.62E-08	3.62E-08	3.61E-08	3.62E-08	3.61526E-08	102126	0.416712
24	675	0.6742	3.53E-08	3.53E-08	3.53E-08	3.53E-08	3.53E-08	3.52644E-08	99616.95	0.416685
25	700	0.6977	3.44E-08	3.44E-08	3.44E-08	3.45E-08	3.45E-08	3.44534E-08	97325.99	0.416783

26	725	0.7229	3.35E-08	3.35E-08	3.35E-08	3.35E-08	3.35E-08	3.34906E-08	94606.21	0.416731
27	750	0.75	3.27E-08	3.27E-08	3.27E-08	3.27E-08	3.27E-08	3.26666E-08	92278.53	0.417533
28	775	0.7792	3.18E-08	3.18E-08	3.18E-08	3.18E-08	3.18E-08	3.18102E-08	89859.32	0.417624
29	800	0.8	3.13E-08	3.13E-08	3.13E-08	3.13E-08	3.13E-08	3.12842E-08	88373.45	0.416775
30	825	0.8219	3.08E-08	3.08E-08	3.08E-08	3.08E-08	3.08E-08	3.08038E-08	87016.38	0.416835
31	850	0.8451	3.03E-08	3.03E-08	3.02E-08	3.02E-08	3.02E-08	3.02266E-08	85385.88	0.421607
32	875	0.8696	2.95E-08	2.95E-08	2.95E-08	2.95E-08	2.95E-08	2.9462E-08	83225.99	0.416704
33	900	0.8955	2.91E-08	2.91E-08	2.91E-08	2.91E-08	2.91E-08	2.90892E-08	82172.88	0.418226
34	925	0.9231	2.84E-08	2.84E-08	2.84E-08	2.84E-08	2.84E-08	2.83876E-08	80190.96	0.417013
35	950	0.9524	2.79E-08	2.79E-08	2.79E-08	2.79E-08	2.79E-08	2.78686E-08	78724.86	0.417193
36	975	0.9678	2.77E-08	2.77E-08	2.78E-08	2.78E-08	2.78E-08	2.77484E-08	78385.31	0.416714
37	1000	1	2.72E-08	2.02E-08	2.72E-08	2.72E-08	2.72E-08	2.5761E-08	72771.19	5.44762
38	1025	1.017	2.68E-08	2.69E-08	2.69E-08	2.68E-08	2.69E-08	2.68488E-08	75844.07	0.416704
39	1050	1.0526	2.62E-08	2.62E-08	2.62E-08	2.62E-08	2.62E-08	2.61692E-08	73924.29	0.416764
40	1075	1.0714	2.58E-08	2.58E-08	2.58E-08	2.58E-08	2.58E-08	2.58438E-08	73005.08	0.416702
41	1100	1.0909	2.55E-08	2.55E-08	2.55E-08	2.55E-08	2.55E-08	2.55178E-08	72084.18	0.416699
42	1125	1.1321	2.49E-08	2.49E-08	2.49E-08	2.49E-08	2.49E-08	2.48798E-08	70281.92	0.416679
43	1150	1.1539	2.46E-08	2.46E-08	2.46E-08	2.46E-08	2.46E-08	2.45838E-08	69445.76	0.416673
44	1175	1.1765	2.43E-08	2.43E-08	2.43E-08	2.43E-08	2.43E-08	2.42636E-08	68541.24	0.416674
45	1200	1.2	2.4E-08	2.4E-08	2.4E-08	2.4E-08	2.4E-08	2.39576E-08	67676.84	0.416693
46	1225	1.2245	2.36E-08	2.36E-08	2.36E-08	2.36E-08	2.36E-08	2.3635E-08	66765.54	0.416686
47	1250	1.25	2.33E-08	2.33E-08	2.33E-08	2.33E-08	2.33E-08	2.32966E-08	65809.6	0.416681
48	1275	1.2766	2.3E-08	2.3E-08	2.3E-08	2.3E-08	2.3E-08	2.29748E-08	64900.56	0.416697
49	1300	1.3044	2.26E-08	2.26E-08	2.26E-08	2.26E-08	2.26E-08	2.26374E-08	63947.46	0.416752
50	1325	1.3333	2.23E-08	2.23E-08	2.23E-08	2.23E-08	2.23E-08	2.23134E-08	63032.2	0.416707
51	1350	1.3636	2.2E-08	2.2E-08	2.2E-08	2.2E-08	2.2E-08	2.20138E-08	62185.88	0.416668
52	1375	1.3636	2.21E-08	2.21E-08	2.21E-08	2.21E-08	2.21E-08	2.2052E-08	62293.79	0.416679
53	1400	1.3954	2.16E-08	2.15E-08	2.15E-08	2.15E-08	2.15E-08	2.15328E-08	60827.12	0.41748
54	1425	1.4286	2.11E-08	2.11E-08	2.11E-08	2.11E-08	2.11E-08	2.11244E-08	59673.45	0.416674
55	1450	1.4634	2.08E-08	2.08E-08	2.08E-08	2.08E-08	2.08E-08	2.07958E-08	58745.2	0.416671
56	1475	1.4634	2.08E-08	2.08E-08	2.09E-08	2.09E-08	2.09E-08	2.08542E-08	58910.17	0.416875
57	1500	1.5	2.05E-08	2.05E-08	2.05E-08	2.05E-08	2.06E-08	2.0548E-08	58045.2	0.416681
58	1525	1.5385	2.02E-08	2.02E-08	2.02E-08	2.02E-08	2.02E-08	2.01934E-08	57043.5	0.416721
59	1550	1.5385	2.02E-08	2.02E-08	2.02E-08	2.02E-08	2.02E-08	2.01888E-08	57030.51	0.416677
60	1575	1.579	1.98E-08	1.98E-08	1.88E-08	1.98E-08	1.98E-08	1.9602E-08	55372.88	1.102116
61	1600	1.579	1.98E-08	1.98E-08	1.98E-08	1.98E-08	1.98E-08	1.98088E-08	55957.06	0.417178
62	1625	1.6216	1.94E-08	1.94E-08	1.94E-08	1.94E-08	1.94E-08	1.93792E-08	54743.5	0.416722
63	1650	1.6667	1.9E-08	1.9E-08	1.9E-08	1.9E-08	1.9E-08	1.9016E-08	53717.51	0.416703
64	1675	1.6667	1.9E-08	1.9E-08	1.9E-08	1.9E-08	1.9E-08	1.90018E-08	53677.4	0.416681
65	1700	1.7143	1.86E-08	1.86E-08	1.86E-08	1.86E-08	1.86E-08	1.8612E-08	52576.27	0.416667
66	1725	1.7143	1.86E-08	1.86E-08	1.86E-08	1.86E-08	1.86E-08	1.86198E-08	52598.31	0.416692
67	1750	1.7647	1.82E-08	1.82E-08	1.82E-08	1.82E-08	1.82E-08	1.82334E-08	51506.78	0.416759
68	1775	1.7647	1.82E-08	1.82E-08	1.82E-08	1.82E-08	1.82E-08	1.82264E-08	51487.01	0.416774
69	1800	1.8182	1.78E-08	1.78E-08	1.78E-08	1.78E-08	1.78E-08	1.78398E-08	50394.92	0.416687
70	1825	1.8182	1.78E-08	1.78E-08	1.78E-08	1.78E-08	1.78E-08	1.78454E-08	50410.73	0.416688
71	1850	1.875	1.75E-08	1.75E-08	1.75E-08	1.75E-08	1.75E-08	1.7452E-08	49299.44	0.416698
72	1875	1.875	1.75E-08	1.75E-08	1.75E-08	1.75E-08	1.75E-08	1.74566E-08	49312.43	0.416685
73	1900	1.875	1.75E-08	1.75E-08	1.75E-08	1.75E-08	1.75E-08	1.7467E-08	49341.81	0.416686
74	1925	1.9355	1.71E-08	1.71E-08	1.71E-08	1.71E-08	1.71E-08	1.70704E-08	48221.47	0.41669
75	1950	1.9355	1.71E-08	1.71E-08	1.71E-08	1.71E-08	1.71E-08	1.70642E-08	48203.95	0.41671
76	1975	2	1.67E-08	1.67E-08	1.67E-08	1.67E-08	1.67E-08	1.66552E-08	47048.59	0.416669
77	2000	2	1.66E-08	1.66E-08	1.66E-08	1.6E-08	1.6E-08	1.63934E-08	46309.04	0.988386

3. Sampel C

No	F (Hz)	F (kHz)	C1 (F)	C2 (F)	C3 (F)	C4 (F)	C5 (F)	Crata-rata (F)	ε	Kr
1	100	0.1	2.53E-07	2.53E-07	2.53E-07	2.53E-07	2.52E-07	2.52776E-07	714056.5	0.421766
2	125	0.125	1.99E-07	1.99E-07	1.99E-07	1.99E-07	1.99E-07	1.9918E-07	562655.4	0.419449
3	150	0.15	1.65E-07	1.65E-07	1.64E-07	1.64E-07	1.64E-07	1.6438E-07	464350.3	0.420081
4	175	0.1765	1.39E-07	1.39E-07	1.39E-07	1.39E-07	1.39E-07	1.3897E-07	392570.6	0.417926
5	200	0.2	1.22E-07	1.22E-07	1.22E-07	1.22E-07	1.22E-07	1.22216E-07	345242.9	0.418067
6	225	0.2308	1.06E-07	1.06E-07	1.06E-07	1.06E-07	1.06E-07	1.05792E-07	298847.5	0.41802
7	250	0.25	9.76E-08	9.76E-08	9.75E-08	9.75E-08	9.75E-08	9.75334E-08	275518.1	0.417461
8	275	0.2752	8.85E-08	8.85E-08	8.85E-08	8.85E-08	8.84E-08	8.84828E-08	249951.4	0.417325
9	300	0.3	8.11E-08	8.1E-08	8.1E-08	8.1E-08	8.09E-08	8.10014E-08	228817.5	0.417558
10	325	0.3243	7.49E-08	7.49E-08	7.49E-08	7.48E-08	7.48E-08	7.48742E-08	211509	0.417631
11	350	0.3509	6.89E-08	6.89E-08	6.89E-08	6.89E-08	6.89E-08	6.89096E-08	194659.9	0.417
12	375	0.375	6.46E-08	6.46E-08	6.46E-08	6.45E-08	6.45E-08	6.4566E-08	182389.8	0.417143
13	400	0.4	6.07E-08	6.07E-08	6.07E-08	6.06E-08	6.06E-08	6.06478E-08	171321.5	0.417772
14	425	0.4255	5.71E-08	5.71E-08	5.71E-08	5.7E-08	5.7E-08	5.70654E-08	161201.7	0.417124
15	450	0.4511	5.4E-08	5.4E-08	5.4E-08	5.4E-08	5.39E-08	5.39678E-08	152451.4	0.417019
16	475	0.4762	5.13E-08	5.13E-08	5.13E-08	5.13E-08	5.13E-08	5.1307E-08	144935	0.416826
17	500	0.5	4.9E-08	4.9E-08	4.9E-08	4.9E-08	4.9E-08	4.90252E-08	138489.3	0.416853
18	525	0.5263	4.68E-08	4.68E-08	4.68E-08	4.68E-08	4.68E-08	4.6789E-08	132172.3	0.417011
19	550	0.5505	4.49E-08	4.49E-08	4.49E-08	4.48E-08	4.48E-08	4.48598E-08	126722.6	0.417047
20	575	0.5769	4.3E-08	4.29E-08	4.29E-08	4.29E-08	4.29E-08	4.29382E-08	121294.4	0.416806
21	600	0.6	4.14E-08	4.14E-08	4.13E-08	4.13E-08	4.13E-08	4.1345E-08	116793.8	0.417064
22	625	0.625	3.98E-08	3.98E-08	3.98E-08	3.98E-08	3.98E-08	3.9825E-08	112500	0.416713
23	650	0.6522	3.83E-08	3.83E-08	3.83E-08	3.83E-08	3.83E-08	3.82676E-08	108100.6	0.416786
24	675	0.6742	3.71E-08	3.71E-08	3.71E-08	3.71E-08	3.71E-08	3.70874E-08	104766.7	0.416725
25	700	0.6977	3.59E-08	3.59E-08	3.59E-08	3.59E-08	3.59E-08	3.58652E-08	101314.1	0.416755
26	725	0.7229	3.47E-08	3.47E-08	3.47E-08	3.47E-08	3.47E-08	3.47216E-08	98083.62	0.416684
27	750	0.75	3.36E-08	3.36E-08	3.36E-08	3.36E-08	3.36E-08	3.36204E-08	94972.88	0.416707
28	775	0.7792	3.26E-08	3.26E-08	3.26E-08	3.26E-08	3.26E-08	3.25606E-08	91979.1	0.416692
29	800	0.8	3.19E-08	3.19E-08	3.19E-08	3.19E-08	3.19E-08	3.18552E-08	89986.44	0.416725
30	825	0.8219	3.11E-08	3.11E-08	3.11E-08	3.11E-08	3.11E-08	3.10778E-08	87790.4	0.416712
31	850	0.8451	3.03E-08	3.03E-08	3.03E-08	3.03E-08	3.03E-08	3.0326E-08	85666.67	0.416725
32	875	0.8696	2.96E-08	2.96E-08	2.96E-08	2.96E-08	2.96E-08	2.95746E-08	83544.07	0.416699
33	900	0.8955	2.88E-08	2.88E-08	2.88E-08	2.88E-08	2.88E-08	2.88316E-08	81445.2	0.416673
34	925	0.9231	2.81E-08	2.81E-08	2.81E-08	2.81E-08	2.81E-08	2.81084E-08	79402.26	0.416827
35	950	0.9524	2.74E-08	2.74E-08	2.74E-08	2.74E-08	2.74E-08	2.73606E-08	77289.83	0.416696
36	975	0.9678	2.7E-08	2.7E-08	2.7E-08	2.7E-08	2.7E-08	2.69846E-08	76227.68	0.416737
37	1000	1	2.65E-08	2.65E-08	2.64E-08	2.64E-08	2.64E-08	2.64572E-08	74737.85	0.422226
38	1025	1.017	2.59E-08	2.59E-08	2.59E-08	2.59E-08	2.59E-08	2.59182E-08	73215.25	0.416748
39	1050	1.0526	2.52E-08	2.52E-08	2.52E-08	2.52E-08	2.52E-08	2.51574E-08	71066.1	0.416728
40	1075	1.0714	2.48E-08	2.48E-08	2.48E-08	2.48E-08	2.48E-08	2.47588E-08	69940.11	0.416791
41	1100	1.0909	2.43E-08	2.43E-08	2.43E-08	2.43E-08	2.43E-08	2.43408E-08	68759.32	0.416785
42	1125	1.1321	2.36E-08	2.36E-08	2.36E-08	2.36E-08	2.36E-08	2.3596E-08	66655.37	0.416777
43	1150	1.1539	2.32E-08	2.32E-08	2.32E-08	2.32E-08	2.32E-08	2.31914E-08	65512.43	0.416677
44	1175	1.1765	2.28E-08	2.28E-08	2.28E-08	2.28E-08	2.28E-08	2.28064E-08	64424.86	0.416687
45	1200	1.2	2.24E-08	2.24E-08	2.24E-08	2.24E-08	2.24E-08	2.2436E-08	63378.53	0.416679

46	1225	1.2245	2.21E-08	2.21E-08	2.21E-08	2.21E-08	2.21E-08	2.20928E-08	62409.04	0.416744
47	1250	1.25	2.17E-08	2.17E-08	2.17E-08	2.17E-08	2.17E-08	2.17244E-08	61368.36	0.416681
48	1275	1.2766	2.14E-08	2.14E-08	2.14E-08	2.14E-08	2.14E-08	2.13568E-08	60329.94	0.416678
49	1300	1.3044	2.1E-08	2.1E-08	2.1E-08	2.1E-08	2.1E-08	2.09812E-08	59268.93	0.416739
50	1325	1.3333	2.06E-08	2.06E-08	2.06E-08	2.06E-08	2.06E-08	2.0599E-08	58189.27	0.416675
51	1350	1.3636	2.02E-08	2.02E-08	2.02E-08	2.02E-08	2.02E-08	2.02246E-08	57131.64	0.416686
52	1375	1.3636	2.02E-08	2.02E-08	2.02E-08	2.02E-08	2.02E-08	2.01946E-08	57046.89	0.416716
53	1400	1.3954	1.98E-08	1.98E-08	1.98E-08	1.98E-08	1.98E-08	1.98066E-08	55950.85	0.416672
54	1425	1.4286	1.94E-08	1.94E-08	1.94E-08	1.94E-08	1.94E-08	1.94164E-08	54848.59	0.416672
55	1450	1.4634	1.9E-08	1.9E-08	1.9E-08	1.9E-08	1.9E-08	1.9036E-08	53774.01	0.41671
56	1475	1.4634	1.9E-08	1.9E-08	1.9E-08	1.9E-08	1.9E-08	1.90058E-08	53688.7	0.416804
57	1500	1.5	1.86E-08	1.86E-08	1.86E-08	1.86E-08	1.86E-08	1.86176E-08	52592.09	0.416714
58	1525	1.5385	1.83E-08	1.83E-08	1.82E-08	1.83E-08	1.82E-08	1.82494E-08	51551.98	0.416683
59	1550	1.5385	1.82E-08	1.82E-08	1.82E-08	1.82E-08	1.82E-08	1.8237E-08	51516.95	0.416696
60	1575	1.579	1.79E-08	1.79E-08	1.79E-08	1.79E-08	1.79E-08	1.78546E-08	50436.72	0.416895
61	1600	1.579	1.79E-08	1.79E-08	1.79E-08	1.79E-08	1.79E-08	1.78594E-08	50450.28	0.416684
62	1625	1.6216	1.74E-08	1.74E-08	1.74E-08	1.74E-08	1.74E-08	1.74364E-08	49255.37	0.416689
63	1650	1.6667	1.7E-08	1.7E-08	1.7E-08	1.7E-08	1.7E-08	1.70334E-08	48116.95	0.416727
64	1675	1.6667	1.7E-08	1.7E-08	1.7E-08	1.7E-08	1.7E-08	1.70068E-08	48041.81	0.416772
65	1700	1.7143	1.66E-08	1.66E-08	1.66E-08	1.66E-08	1.66E-08	1.66208E-08	46951.41	0.416699
66	1725	1.7143	1.66E-08	1.66E-08	1.66E-08	1.66E-08	1.66E-08	1.65976E-08	46885.88	0.416739
67	1750	1.7647	1.62E-08	1.62E-08	1.62E-08	1.62E-08	1.62E-08	1.62272E-08	45839.55	0.416668
68	1775	1.7647	1.62E-08	1.62E-08	1.62E-08	1.62E-08	1.62E-08	1.62162E-08	45808.47	0.416673
69	1800	1.8182	1.58E-08	1.58E-08	1.58E-08	1.58E-08	1.58E-08	1.58328E-08	44725.42	0.416712
70	1825	1.8182	1.58E-08	1.58E-08	1.58E-08	1.58E-08	1.58E-08	1.58056E-08	44648.59	0.416694
71	1850	1.875	1.54E-08	1.54E-08	1.54E-08	1.54E-08	1.54E-08	1.54304E-08	43588.7	0.416675
72	1875	1.875	1.54E-08	1.54E-08	1.54E-08	1.54E-08	1.54E-08	1.54116E-08	43535.59	0.416669
73	1900	1.875	1.54E-08	1.54E-08	1.54E-08	1.54E-08	1.54E-08	1.5389E-08	43471.75	0.416692
74	1925	1.9355	1.5E-08	1.5E-08	1.5E-08	1.5E-08	1.5E-08	1.5009E-08	42398.31	0.418166
75	1950	1.9355	1.5E-08	1.5E-08	1.5E-08	1.5E-08	1.5E-08	1.49842E-08	42328.25	0.416728
76	1975	2	1.46E-08	1.46E-08	1.46E-08	1.46E-08	1.46E-08	1.4602E-08	41248.59	0.416734
77	2000	2	1.46E-08	1.46E-08	1.46E-08	1.46E-08	1.46E-08	1.45852E-08	41201.13	0.416697

4. Sampel D

No	F (Hz)	F (kHz)	C1 (F)	C2 (F)	C3 (F)	C4 (F)	C5 (F)	Crata-rata (F)	ε	Kr
1	100	0.1	2.27E-07	2.26E-07	2.26E-07	2.26E-07	2.26E-07	2.26284E-07	639220.3	0.420204
2	125	0.125	1.81E-07	1.81E-07	1.81E-07	1.81E-07	1.81E-07	1.81162E-07	511757.1	0.417815
3	150	0.15	1.48E-07	1.48E-07	1.48E-07	1.48E-07	1.47E-07	1.47552E-07	416813.6	0.417632
4	175	0.1765	1.25E-07	1.25E-07	1.25E-07	1.25E-07	1.25E-07	1.25036E-07	353209	0.419685
5	200	0.2	1.1E-07	1.1E-07	1.1E-07	1.1E-07	1.09E-07	1.09614E-07	309644.1	0.420193
6	225	0.2308	9.46E-08	9.46E-08	9.45E-08	9.46E-08	9.44E-08	9.45532E-08	267099.4	0.418994
7	250	0.25	8.7E-08	8.69E-08	8.69E-08	8.68E-08	8.68E-08	8.68702E-08	245396	0.418732
8	275	0.2752	7.91E-08	7.9E-08	7.9E-08	7.9E-08	7.9E-08	7.90032E-08	223172.9	0.417047
9	300	0.3	7.29E-08	7.28E-08	7.28E-08	7.28E-08	7.27E-08	7.27978E-08	205643.5	0.417644
10	325	0.3243	6.75E-08	6.75E-08	6.75E-08	6.74E-08	6.74E-08	6.74528E-08	190544.6	0.417126
11	350	0.3509	6.26E-08	6.25E-08	6.25E-08	6.25E-08	6.25E-08	6.25158E-08	176598.3	0.4181
12	375	0.375	5.79E-08	5.79E-08	5.79E-08	5.78E-08	5.78E-08	5.78506E-08	163419.8	0.416989
13	400	0.4	5.44E-08	5.44E-08	5.44E-08	5.44E-08	5.44E-08	5.44126E-08	153707.9	0.417092
14	425	0.4255	5.14E-08	5.13E-08	5.13E-08	5.14E-08	5.13E-08	5.1347E-08	145048	0.416738
15	450	0.4511	4.85E-08	4.85E-08	4.85E-08	4.85E-08	4.84E-08	4.84638E-08	136903.4	0.417111

16	475	0.4762	4.61E-08	4.61E-08	4.61E-08	4.61E-08	4.61E-08	4.6075E-08	130155.4	0.416786
17	500	0.5	4.41E-08	4.41E-08	4.41E-08	4.41E-08	4.41E-08	4.41122E-08	124610.7	0.416774
18	525	0.5263	4.22E-08	4.22E-08	4.22E-08	4.22E-08	4.22E-08	4.22174E-08	119258.2	0.416782
19	550	0.5505	4.06E-08	4.06E-08	4.06E-08	4.06E-08	4.06E-08	4.05964E-08	114679.1	0.416891
20	575	0.5769	3.9E-08	3.9E-08	3.89E-08	3.89E-08	3.89E-08	3.89478E-08	110022	0.416773
21	600	0.6	3.77E-08	3.77E-08	3.77E-08	3.77E-08	3.76E-08	3.76494E-08	106350.4	0.41708
22	625	0.625	3.63E-08	3.63E-08	3.63E-08	3.63E-08	3.63E-08	3.63096E-08	102569.5	0.416728
23	650	0.6522	3.51E-08	3.51E-08	3.51E-08	3.51E-08	3.51E-08	3.5096E-08	99141.24	0.417007
24	675	0.6742	3.41E-08	3.41E-08	3.41E-08	3.41E-08	3.41E-08	3.41014E-08	96331.64	0.41684
25	700	0.6977	3.31E-08	3.31E-08	3.31E-08	3.31E-08	3.31E-08	3.31364E-08	93605.65	0.416701
26	725	0.7229	3.22E-08	3.22E-08	3.22E-08	3.22E-08	3.22E-08	3.21668E-08	90866.67	0.416675
27	750	0.75	3.12E-08	3.13E-08	3.12E-08	3.12E-08	3.12E-08	3.12384E-08	88244.07	0.416928
28	775	0.7792	3.03E-08	3.03E-08	3.03E-08	3.03E-08	3.03E-08	3.03036E-08	85603.39	0.416921
29	800	0.8	2.96E-08	2.96E-08	2.96E-08	2.96E-08	2.96E-08	2.96288E-08	83697.18	0.416783
30	825	0.8219	2.89E-08	2.89E-08	2.89E-08	2.89E-08	2.89E-08	2.8947E-08	81771.19	0.416743
31	850	0.8451	2.83E-08	2.83E-08	2.83E-08	2.83E-08	2.83E-08	2.83404E-08	80057.63	0.416733
32	875	0.8696	2.77E-08	2.77E-08	2.77E-08	2.77E-08	2.77E-08	2.76896E-08	78219.21	0.416804
33	900	0.8955	2.64E-08	2.64E-08	2.64E-08	2.64E-08	2.64E-08	2.63972E-08	74568.36	0.416707
34	925	0.9231	2.57E-08	2.57E-08	2.58E-08	2.58E-08	2.58E-08	2.57498E-08	72739.55	0.416767
35	950	0.9524	2.5E-08	2.5E-08	2.5E-08	2.5E-08	2.5E-08	2.50086E-08	70645.76	0.41828
36	975	0.9678	2.47E-08	2.47E-08	2.47E-08	2.47E-08	2.47E-08	2.47128E-08	69810.17	0.416917
37	1000	1	2.41E-08	2.41E-08	2.41E-08	2.41E-08	2.41E-08	2.41106E-08	68109.04	0.417175
38	1025	1.017	2.37E-08	2.37E-08	2.37E-08	2.37E-08	2.37E-08	2.3736E-08	67050.85	0.416752
39	1050	1.0526	2.31E-08	2.31E-08	2.31E-08	2.31E-08	2.31E-08	2.31186E-08	65306.78	0.416695
40	1075	1.0714	2.28E-08	2.28E-08	2.28E-08	2.28E-08	2.28E-08	2.28264E-08	64481.36	0.416691
41	1100	1.0909	2.25E-08	2.25E-08	2.25E-08	2.25E-08	2.25E-08	2.24876E-08	63524.29	0.416782
42	1125	1.1321	2.2E-08	2.2E-08	2.2E-08	2.2E-08	2.2E-08	2.19596E-08	62032.77	0.41682
43	1150	1.1539	2.15E-08	2.15E-08	2.16E-08	2.16E-08	2.15E-08	2.15518E-08	60880.79	0.416887
44	1175	1.1765	2.12E-08	2.12E-08	2.12E-08	2.12E-08	2.12E-08	2.12138E-08	59925.99	0.416726
45	1200	1.2	2.09E-08	2.09E-08	2.09E-08	2.09E-08	2.09E-08	2.09078E-08	59061.58	0.416676
46	1225	1.2245	2.06E-08	2.06E-08	2.06E-08	2.06E-08	2.06E-08	2.06372E-08	58297.18	0.416795
47	1250	1.25	2.04E-08	2.03E-08	2.03E-08	2.03E-08	2.03E-08	2.0343E-08	57466.1	0.417081
48	1275	1.2766	2E-08	2E-08	2E-08	2E-08	2E-08	2.00032E-08	56506.21	0.416842
49	1300	1.3044	1.97E-08	1.97E-08	1.97E-08	1.97E-08	1.97E-08	1.96876E-08	55614.69	0.416737
50	1325	1.3333	1.93E-08	1.94E-08	1.94E-08	1.94E-08	1.94E-08	1.93528E-08	54668.93	0.416754
51	1350	1.3636	1.91E-08	1.92E-08	1.92E-08	1.92E-08	1.92E-08	1.91566E-08	54114.69	0.416982
52	1375	1.3636	1.91E-08	1.91E-08	1.91E-08	1.91E-08	1.91E-08	1.90748E-08	53883.62	0.416701
53	1400	1.3954	1.87E-08	1.87E-08	1.88E-08	1.87E-08	1.88E-08	1.87502E-08	52966.67	0.416753
54	1425	1.4286	1.85E-08	1.84E-08	1.84E-08	1.84E-08	1.84E-08	1.84436E-08	52100.56	0.417198
55	1450	1.4634	1.81E-08	1.81E-08	1.81E-08	1.81E-08	1.81E-08	1.80812E-08	51076.84	0.416767
56	1475	1.4634	1.81E-08	1.81E-08	1.81E-08	1.81E-08	1.8E-08	1.80518E-08	50993.79	0.41672
57	1500	1.5	1.77E-08	1.77E-08	1.77E-08	1.77E-08	1.77E-08	1.76858E-08	49959.89	0.416676
58	1525	1.5385	1.74E-08	1.74E-08	1.74E-08	1.74E-08	1.74E-08	1.7364E-08	49050.85	0.416691
59	1550	1.5385	1.74E-08	1.74E-08	1.74E-08	1.74E-08	1.74E-08	1.737E-08	49067.8	0.416726
60	1575	1.579	1.7E-08	1.7E-08	1.7E-08	1.7E-08	1.7E-08	1.70398E-08	48135.03	0.416743
61	1600	1.579	1.72E-08	1.72E-08	1.71E-08	1.71E-08	1.71E-08	1.71434E-08	48427.68	0.427698
62	1625	1.6216	1.66E-08	1.66E-08	1.66E-08	1.66E-08	1.66E-08	1.66368E-08	46996.61	0.416768
63	1650	1.6667	1.63E-08	1.63E-08	1.63E-08	1.63E-08	1.63E-08	1.62746E-08	45973.45	0.416678
64	1675	1.6667	1.63E-08	1.63E-08	1.63E-08	1.63E-08	1.63E-08	1.62672E-08	45952.54	0.416682
65	1700	1.7143	1.6E-08	1.6E-08	1.6E-08	1.6E-08	1.6E-08	1.59642E-08	45096.61	0.416734

66	1725	1.7143	1.6E-08	1.6E-08	1.6E-08	1.6E-08	1.6E-08	1.59882E-08	45164.41	0.417166
67	1750	1.7647	1.57E-08	1.57E-08	1.57E-08	1.57E-08	1.57E-08	1.5664E-08	44248.59	0.416686
68	1775	1.7647	1.57E-08	1.57E-08	1.57E-08	1.57E-08	1.57E-08	1.56556E-08	44224.86	0.416679
69	1800	1.8182	1.53E-08	1.53E-08	1.53E-08	1.53E-08	1.53E-08	1.53306E-08	43306.78	0.416669
70	1825	1.8182	1.53E-08	1.53E-08	1.53E-08	1.53E-08	1.53E-08	1.53232E-08	43285.88	0.416689
71	1850	1.875	1.5E-08	1.5E-08	1.5E-08	1.5E-08	1.5E-08	1.4991E-08	42347.46	0.416667
72	1875	1.875	1.5E-08	1.5E-08	1.5E-08	1.5E-08	1.5E-08	1.499E-08	42344.63	0.416789
73	1900	1.875	1.5E-08	1.5E-08	1.5E-08	1.5E-08	1.5E-08	1.49958E-08	42361.02	0.416738
74	1925	1.9355	1.47E-08	1.47E-08	1.47E-08	1.47E-08	1.47E-08	1.46644E-08	41424.86	0.416849
75	1950	1.9355	1.47E-08	1.47E-08	1.47E-08	1.47E-08	1.47E-08	1.46876E-08	41490.4	0.417542
76	1975	2	1.44E-08	1.44E-08	1.44E-08	1.44E-08	1.44E-08	1.43594E-08	40563.28	0.416949
77	2000	2	1.43E-08	1.43E-08	1.43E-08	1.43E-08	1.43E-08	1.4331E-08	40483.05	0.416813

e. 40 mL

1. Sampel A

No	F (Hz)	F (kHz)	C1 (F)	C2 (F)	C3 (F)	C4 (F)	C5 (F)	C rata-rata (F)	ε	Kf
1	100	0.1	4.43E-07	4.44E-07	4.44E-07	4.44E-07	4.44E-07	4.4375E-07	1253531	0.41736
2	125	0.125	3.63E-07	3.62E-07	3.62E-07	3.61E-07	3.6E-07	3.61498E-07	1021181	0.43437
3	150	0.15	3.03E-07	3.03E-07	3.03E-07	3.02E-07	3.02E-07	3.0274E-07	855198	0.4241
4	175	0.175	2.58E-07	2.58E-07	2.57E-07	2.57E-07	2.57E-07	2.5732E-07	726893	0.42126
5	200	0.2	2.27E-07	2.27E-07	2.27E-07	2.27E-07	2.26E-07	2.26714E-07	640435	0.42141
6	225	0.231	1.97E-07	1.97E-07	1.97E-07	1.97E-07	1.97E-07	1.96964E-07	556395	0.42053
7	250	0.25	1.81E-07	1.81E-07	1.81E-07	1.81E-07	1.81E-07	1.80926E-07	511090	0.41875
8	275	0.275	1.65E-07	1.64E-07	1.64E-07	1.64E-07	1.64E-07	1.64356E-07	464282	0.41892
9	300	0.3	1.51E-07	1.51E-07	1.51E-07	1.51E-07	1.5E-07	1.50574E-07	425350	0.41752
10	325	0.324	1.39E-07	1.39E-07	1.39E-07	1.39E-07	1.39E-07	1.38956E-07	392531	0.41811
11	350	0.351	1.28E-07	1.28E-07	1.28E-07	1.28E-07	1.28E-07	1.27754E-07	360887	0.41768
12	375	0.375	1.21E-07	1.21E-07	1.21E-07	1.21E-07	1.21E-07	1.20882E-07	341475	0.41938
13	400	0.4	1.11E-07	1.11E-07	1.11E-07	1.11E-07	1.11E-07	1.108E-07	312994	0.42146
14	425	0.426	1.03E-07	1.03E-07	1.03E-07	1.03E-07	1.02E-07	1.0256E-07	289718	0.41779
15	450	0.451	9.63E-08	9.62E-08	9.62E-08	9.62E-08	9.61E-08	9.61982E-08	271746	0.41872
16	475	0.476	9.1E-08	9.09E-08	9.09E-08	9.09E-08	9.08E-08	9.08738E-08	256706	0.41809
17	500	0.5	8.62E-08	8.62E-08	8.61E-08	8.61E-08	8.6E-08	8.61244E-08	243289	0.41837
18	525	0.526	8.15E-08	8.14E-08	8.14E-08	8.14E-08	8.13E-08	8.13984E-08	229939	0.41799
19	550	0.55	7.8E-08	7.79E-08	7.78E-08	7.78E-08	7.78E-08	7.78614E-08	219947	0.41845
20	575	0.577	7.41E-08	7.4E-08	7.4E-08	7.4E-08	7.4E-08	7.4016E-08	209085	0.41713
21	600	0.6	7.11E-08	7.1E-08	7.1E-08	7.1E-08	7.1E-08	7.10344E-08	200662	0.41673
22	625	0.625	6.41E-08	6.41E-08	6.4E-08	6.4E-08	6.4E-08	6.40464E-08	180922	0.41809
23	650	0.652	6.13E-08	6.13E-08	6.13E-08	6.13E-08	6.13E-08	6.12704E-08	173080	0.41684
24	675	0.674	5.93E-08	5.93E-08	5.93E-08	5.93E-08	5.93E-08	5.93274E-08	167592	0.41687
25	700	0.698	5.74E-08	5.73E-08	5.73E-08	5.73E-08	5.73E-08	5.7332E-08	161955	0.41695
26	725	0.723	5.56E-08	5.56E-08	5.55E-08	5.55E-08	5.55E-08	5.55474E-08	156914	0.41793
27	750	0.75	5.37E-08	5.37E-08	5.36E-08	5.37E-08	5.36E-08	5.36556E-08	151569	0.4171
28	775	0.779	5.13E-08	5.13E-08	5.13E-08	5.13E-08	5.13E-08	5.13228E-08	144980	0.41701
29	800	0.8	5E-08	5E-08	5E-08	5E-08	5E-08	4.99962E-08	141232	0.41706
30	825	0.822	4.85E-08	4.85E-08	4.85E-08	4.85E-08	4.85E-08	4.84846E-08	136962	0.41706

31	850	0.845	4.71E-08	4.71E-08	4.71E-08	4.71E-08	4.71E-08	4.71E-08	4.71102E-08	133080	0.41671
32	875	0.87	4.68E-08	4.68E-08	4.68E-08	4.67E-08	4.68E-08	4.67726E-08	4.67726E-08	132126	0.41711
33	900	0.896	4.44E-08	4.44E-08	4.44E-08	4.44E-08	4.44E-08	4.44E-08	4.44002E-08	125424	0.41673
34	925	0.923	4.32E-08	4.32E-08	4.32E-08	4.32E-08	4.32E-08	4.32E-08	4.32248E-08	122104	0.4167
35	950	0.952	4.2E-08	4.2E-08	4.2E-08	4.2E-08	4.2E-08	4.2E-08	4.1987E-08	118607	0.41671
36	975	0.968	4.14E-08	4.14E-08	4.14E-08	4.14E-08	4.14E-08	4.14E-08	4.14422E-08	117068	0.41671
37	1000	1	4.04E-08	4.04E-08	4.04E-08	4.04E-08	4.04E-08	4.04E-08	4.03824E-08	114075	0.41672
38	1025	1.017	3.98E-08	3.98E-08	3.98E-08	3.98E-08	3.98E-08	3.98E-08	3.98024E-08	112436	0.41679
39	1050	1.053	3.87E-08	3.87E-08	3.87E-08	3.87E-08	3.87E-08	3.87E-08	3.86792E-08	109263	0.4167
40	1075	1.071	3.81E-08	3.81E-08	3.81E-08	3.81E-08	3.81E-08	3.81E-08	3.81208E-08	107686	0.41691
41	1100	1.091	3.76E-08	3.76E-08	3.76E-08	3.75E-08	3.75E-08	3.75E-08	3.75568E-08	106093	0.41736
42	1125	1.132	3.64E-08	3.64E-08	3.64E-08	3.64E-08	3.64E-08	3.64E-08	3.64134E-08	102863	0.41696
43	1150	1.154	3.58E-08	3.58E-08	3.58E-08	3.58E-08	3.58E-08	3.58E-08	3.5786E-08	101090	0.41681
44	1175	1.177	3.53E-08	3.53E-08	3.53E-08	3.53E-08	3.53E-08	3.53E-08	3.52866E-08	99679.7	0.4167
45	1200	1.2	3.46E-08	3.46E-08	3.46E-08	3.47E-08	3.47E-08	3.47E-08	3.46578E-08	97903.4	0.41754
46	1225	1.225	3.39E-08	3.39E-08	3.39E-08	3.39E-08	3.39E-08	3.39E-08	3.39124E-08	95797.7	0.41674
47	1250	1.25	3.33E-08	3.33E-08	3.33E-08	3.33E-08	3.33E-08	3.33E-08	3.33342E-08	94164.4	0.417
48	1275	1.277	3.28E-08	3.28E-08	3.28E-08	3.28E-08	3.28E-08	3.27E-08	3.27638E-08	92553.1	0.41689
49	1300	1.304	3.21E-08	3.21E-08	3.21E-08	3.21E-08	3.21E-08	3.21E-08	3.2111E-08	90709	0.41745
50	1325	1.333	3.15E-08	3.15E-08	3.15E-08	3.15E-08	3.15E-08	3.15E-08	3.15264E-08	89057.6	0.4167
51	1350	1.364	3.09E-08	3.09E-08	3.09E-08	3.09E-08	3.09E-08	3.09E-08	3.0884E-08	87242.9	0.41683
52	1375	1.364	3.09E-08	3.1E-08	3.1E-08	3.09E-08	3.09E-08	3.09E-08	3.0947E-08	87420.9	0.41671
53	1400	1.395	3.04E-08	3.04E-08	3.04E-08	3.04E-08	3.04E-08	3.04E-08	3.04308E-08	85962.7	0.41673
54	1425	1.429	2.99E-08	2.99E-08	2.99E-08	2.99E-08	2.99E-08	2.99E-08	2.98646E-08	84363.3	0.41667
55	1450	1.463	2.93E-08	2.93E-08	2.93E-08	2.93E-08	2.93E-08	2.93E-08	2.93178E-08	82818.6	0.41684
56	1475	1.463	2.93E-08	2.93E-08	2.93E-08	2.93E-08	2.93E-08	2.93E-08	2.9292E-08	82745.8	0.41671
57	1500	1.5	2.87E-08	2.87E-08	2.87E-08	2.87E-08	2.87E-08	2.87E-08	2.87304E-08	81159.3	0.4168
58	1525	1.539	2.81E-08	2.81E-08	2.81E-08	2.81E-08	2.81E-08	2.81E-08	2.812E-08	79435	0.41673
59	1550	1.539	2.81E-08	2.81E-08	2.81E-08	2.81E-08	2.81E-08	2.81E-08	2.80944E-08	79362.7	0.41677
60	1575	1.579	2.76E-08	2.76E-08	2.76E-08	2.76E-08	2.76E-08	2.76E-08	2.75652E-08	77867.8	0.4167
61	1600	1.579	2.75E-08	2.75E-08	2.75E-08	2.74E-08	2.74E-08	2.74E-08	2.74626E-08	77578	0.41859
62	1625	1.622	2.69E-08	2.69E-08	2.69E-08	2.69E-08	2.69E-08	2.69E-08	2.69164E-08	76033.9	0.41674
63	1650	1.667	2.63E-08	2.63E-08	2.63E-08	2.63E-08	2.63E-08	2.63E-08	2.67208E-08	75482.5	1.55679
64	1675	1.667	2.62E-08	2.62E-08	2.62E-08	2.62E-08	2.62E-08	2.62E-08	2.61804E-08	73955.9	0.417
65	1700	1.714	2.57E-08	2.57E-08	2.56E-08	2.56E-08	2.56E-08	2.56E-08	2.5648E-08	72452	0.41682
66	1725	1.714	2.55E-08	2.55E-08	2.55E-08	2.55E-08	2.55E-08	2.55E-08	2.55374E-08	72139.5	0.41669
67	1750	1.765	2.5E-08	2.5E-08	2.5E-08	2.5E-08	2.5E-08	2.5E-08	2.49782E-08	70559.9	0.41708
68	1775	1.765	2.49E-08	2.49E-08	2.49E-08	2.49E-08	2.49E-08	2.49E-08	2.4926E-08	70412.4	0.41787
69	1800	1.818	2.44E-08	2.44E-08	2.44E-08	2.43E-08	2.43E-08	2.43E-08	2.43466E-08	68775.7	0.41711
70	1825	1.818	2.43E-08	2.43E-08	2.43E-08	2.43E-08	2.43E-08	2.43E-08	2.42882E-08	68610.7	0.41706
71	1850	1.875	2.37E-08	2.37E-08	2.37E-08	2.37E-08	2.37E-08	2.37E-08	2.37376E-08	67055.4	0.4167
72	1875	1.875	2.36E-08	2.36E-08	2.36E-08	2.36E-08	2.36E-08	2.36E-08	2.3613E-08	66703.4	0.41668
73	1900	1.875	2.3E-08	2.31E-08	2.31E-08	2.31E-08	2.31E-08	2.31E-08	2.3058E-08	65135.6	0.41729
74	1925	1.936	2.3E-08	2.3E-08	2.3E-08	2.3E-08	2.3E-08	2.3E-08	2.2988E-08	64937.9	0.41678
75	1950	1.936	2.26E-08	2.27E-08	2.26E-08	2.27E-08	2.26E-08	2.26E-08	2.26082E-08	63865	0.42982
76	1975	2	2.24E-08	2.24E-08	2.24E-08	2.24E-08	2.24E-08	2.24E-08	2.2407E-08	63296.6	0.41716
77	2000	2	2.23E-08	2.23E-08	2.23E-08	2.23E-08	2.23E-08	2.23E-08	2.234E-08	63107.3	0.41671

2. Sampel B

No	F (Hz)	F (kHz)	C1 (F)	C2 (F)	C3 (F)	C4 (F)	C5 (F)	Crata-rata (F)	ε	Kr
1	100	0.1	3.13E-07	3.13E-07	3.13E-07	3.13E-07	3.12E-07	3.12876E-07	883831	0.43128
2	125	0.125	2.7E-07	2.73E-07	2.73E-07	2.73E-07	2.72E-07	2.72118E-07	768695	0.46893
3	150	0.15	2.33E-07	2.33E-07	2.33E-07	2.33E-07	2.33E-07	2.33174E-07	658684	0.41758
4	175	0.176	2.3E-07	2.31E-07	2.32E-07	2.32E-07	2.32E-07	2.31414E-07	653712	0.46629
5	200	0.2	1.99E-07	2E-07	2.02E-07	2.04E-07	2.05E-07	2.01992E-07	570599	0.68994
6	225	0.231	1.92E-07	1.92E-07	1.92E-07	1.91E-07	1.91E-07	1.91428E-07	540757	0.45391
7	250	0.25	1.81E-07	1.8E-07	1.81E-07	1.81E-07	1.81E-07	1.80804E-07	510746	0.42052
8	275	0.275	1.69E-07	1.69E-07	1.7E-07	1.7E-07	1.7E-07	1.69524E-07	478881	0.43024
9	300	0.3	1.6E-07	1.59E-07	1.59E-07	1.7E-07	1.6E-07	1.6164E-07	456610	1.34337
10	325	0.324	1.52E-07	1.52E-07	1.52E-07	1.52E-07	1.51E-07	1.51588E-07	428215	0.41866
11	350	0.351	1.44E-07	1.44E-07	1.44E-07	1.44E-07	1.44E-07	1.4441E-07	407938	0.41695
12	375	0.375	1.36E-07	1.36E-07	1.37E-07	1.36E-07	1.37E-07	1.3631E-07	385056	0.43334
13	400	0.4	1.3E-07	1.31E-07	1.31E-07	1.31E-07	1.31E-07	1.30828E-07	369571	0.4406
14	425	0.426	1.24E-07	1.24E-07	1.23E-07	1.24E-07	1.4E-07	1.26952E-07	358621	2.6005
15	450	0.451	1.09E-07	1.08E-07	1.09E-07	1.09E-07	1.09E-07	1.08844E-07	307469	0.46362
16	475	0.476	1.12E-07	1.12E-07	1.12E-07	1.13E-07	1.13E-07	1.12366E-07	317418	0.43517
17	500	0.5	1.1E-07	1.1E-07	1.1E-07	1.1E-07	1.1E-07	1.0995E-07	310593	0.43454
18	525	0.526	1.06E-07	1.06E-07	1.06E-07	1.06E-07	1.06E-07	1.06198E-07	299994	0.42026
19	550	0.55	1.04E-07	1.04E-07	1.04E-07	1.04E-07	1.04E-07	1.03928E-07	293582	0.4368
20	575	0.577	1.01E-07	1.01E-07	1.01E-07	1.01E-07	1.01E-07	1.00856E-07	284904	0.41853
21	600	0.6	9.49E-08	9.47E-08	9.46E-08	9.45E-08	9.42E-08	9.45816E-08	267180	0.4327
22	625	0.625	7.98E-08	7.96E-08	7.95E-08	7.94E-08	7.93E-08	7.95034E-08	224586	0.42764
23	650	0.652	7.23E-08	6.71E-08	7.09E-08	7.1E-08	7.09E-08	7.04366E-08	198973	1.3036
24	675	0.674	6.51E-08	6.51E-08	6.5E-08	6.5E-08	6.48E-08	6.50234E-08	183682	0.42555
25	700	0.698	6.08E-08	6.08E-08	6.08E-08	6.1E-08	6.1E-08	6.0886E-08	171994	0.422
26	725	0.723	5.72E-08	5.71E-08	5.72E-08	5.71E-08	5.71E-08	5.71392E-08	161410	0.41734
27	750	0.75	5.42E-08	5.42E-08	5.43E-08	5.42E-08	5.42E-08	5.42226E-08	153171	0.4181
28	775	0.779	5.1E-08	5.1E-08	4.09E-08	5.09E-08	5.1E-08	4.89586E-08	138301	4.11583
29	800	0.8	4.91E-08	4.91E-08	4.92E-08	4.92E-08	4.92E-08	4.91646E-08	138883	0.41962
30	825	0.822	4.79E-08	4.8E-08	4.79E-08	4.79E-08	4.79E-08	4.79262E-08	135385	0.41735
31	850	0.845	4.67E-08	4.67E-08	4.67E-08	4.67E-08	4.67E-08	4.67128E-08	131957	0.41731
32	875	0.87	4.55E-08	4.55E-08	4.55E-08	4.55E-08	4.55E-08	4.54818E-08	128480	0.41731
33	900	0.896	4.4E-08	4.4E-08	4.4E-08	4.4E-08	4.4E-08	4.3966E-08	124198	0.41675
34	925	0.923	4.29E-08	4.27E-08	4.26E-08	4.3E-08	4.29E-08	4.2796E-08	120893	0.45317
35	950	0.952	4.12E-08	4.11E-08	4.12E-08	4.12E-08	4.11E-08	4.11454E-08	116230	0.41768
36	975	0.968	4.09E-08	4.09E-08	4.09E-08	4.09E-08	4.09E-08	4.09122E-08	115571	0.4178
37	1000	1	3.9E-08	3.9E-08	3.9E-08	3.9E-08	3.9E-08	3.90246E-08	110239	0.41685
38	1025	1.017	3.79E-08	3.74E-08	3.73E-08	3.72E-08	3.73E-08	3.73838E-08	105604	0.52671
39	1050	1.053	3.58E-08	3.58E-08	3.57E-08	3.57E-08	3.57E-08	3.5735E-08	100946	0.41949
40	1075	1.071	3.47E-08	3.47E-08	3.46E-08	3.46E-08	3.46E-08	3.46522E-08	97887.6	0.42197
41	1100	1.091	3.36E-08	3.36E-08	3.35E-08	3.35E-08	3.35E-08	3.35382E-08	94740.7	0.42357
42	1125	1.132	3.1E-08	3.1E-08	3.1E-08	3.11E-08	3.11E-08	3.10286E-08	87651.4	0.42008
43	1150	1.154	2.95E-08	2.95E-08	2.94E-08	2.94E-08	2.94E-08	2.94218E-08	83112.4	0.41923
44	1175	1.177	2.86E-08	2.85E-08	2.85E-08	2.87E-08	2.87E-08	2.8571E-08	80709	0.44744
45	1200	1.2	2.67E-08	2.66E-08	2.65E-08	2.64E-08	2.63E-08	2.65086E-08	74883.1	0.48227

46	1225	1.225	2.46E-08	2.46E-08	2.46E-08	2.45E-08	2.44E-08	2.45468E-08	69341.2	0.43994
47	1250	1.25	2.55E-08	2.54E-08	2.54E-08	2.53E-08	2.54E-08	2.54112E-08	71783.1	0.43862
48	1275	1.277	2.46E-08	2.46E-08	2.46E-08	2.46E-08	2.46E-08	2.4589E-08	69460.5	0.4174
49	1300	1.304	2.36E-08	2.36E-08	2.36E-08	2.36E-08	2.36E-08	2.3618E-08	66717.5	0.41763
50	1325	1.333	2.28E-08	2.28E-08	2.27E-08	2.27E-08	2.27E-08	2.2747E-08	64257.1	0.41735
51	1350	1.364	2.21E-08	2.21E-08	2.21E-08	2.21E-08	2.21E-08	2.20942E-08	62413	0.41794
52	1375	1.364	2.15E-08	2.15E-08	2.15E-08	2.15E-08	2.15E-08	2.15354E-08	60834.5	0.41704
53	1400	1.395	2.22E-08	2.21E-08	2.21E-08	2.21E-08	2.21E-08	2.211E-08	62457.6	0.42359
54	1425	1.429	2.1E-08	2.1E-08	2.1E-08	2.1E-08	2.1E-08	2.1001E-08	59324.9	0.42026
55	1450	1.463	2.02E-08	2.02E-08	2.02E-08	2.02E-08	2.02E-08	2.01722E-08	56983.6	0.41908
56	1475	1.463	1.98E-08	1.98E-08	1.98E-08	1.99E-08	2E-08	1.98576E-08	56094.9	0.43509
57	1500	1.5	1.96E-08	1.96E-08	1.96E-08	1.96E-08	1.96E-08	1.95908E-08	55341.2	0.42349
58	1525	1.539	1.89E-08	1.89E-08	1.89E-08	1.89E-08	1.89E-08	1.88904E-08	53362.7	0.4189
59	1550	1.539	1.88E-08	1.88E-08	1.88E-08	1.88E-08	1.88E-08	1.88156E-08	53151.4	0.41768
60	1575	1.579	1.82E-08	1.82E-08	1.82E-08	1.82E-08	1.82E-08	1.81912E-08	51387.6	0.41698
61	1600	1.579	1.83E-08	1.83E-08	1.83E-08	1.83E-08	1.83E-08	1.83086E-08	51719.2	0.41683
62	1625	1.622	1.77E-08	1.77E-08	1.77E-08	1.77E-08	1.77E-08	1.77246E-08	50069.5	0.41867
63	1650	1.667	1.71E-08	1.71E-08	1.71E-08	1.71E-08	1.7E-08	1.70586E-08	48188.1	0.41737
64	1675	1.667	1.68E-08	1.68E-08	1.68E-08	1.68E-08	1.68E-08	1.6822E-08	47519.8	0.41756
65	1700	1.714	1.64E-08	1.64E-08	1.64E-08	1.63E-08	1.63E-08	1.6362E-08	46220.3	0.42141
66	1725	1.714	1.63E-08	1.63E-08	1.63E-08	1.63E-08	1.63E-08	1.63342E-08	46141.8	0.41763
67	1750	1.765	1.58E-08	1.58E-08	1.57E-08	1.57E-08	1.58E-08	1.57484E-08	44487	0.41681
68	1775	1.765	1.58E-08	1.58E-08	1.58E-08	1.58E-08	1.58E-08	1.5771E-08	44550.8	0.41676
69	1800	1.818	1.54E-08	1.54E-08	1.54E-08	1.54E-08	1.54E-08	1.5406E-08	43519.8	0.41692
70	1825	1.818	1.51E-08	1.51E-08	1.51E-08	1.51E-08	1.51E-08	1.51096E-08	42682.5	0.41728
71	1850	1.875	1.47E-08	1.47E-08	1.47E-08	1.47E-08	1.48E-08	1.47364E-08	41628.2	0.41993
72	1875	1.875	1.48E-08	1.48E-08	1.49E-08	1.49E-08	1.49E-08	1.4846E-08	41937.9	0.41918
73	1900	1.875	1.48E-08	1.48E-08	1.48E-08	1.48E-08	1.48E-08	1.4812E-08	41841.8	0.41774
74	1925	1.936	1.42E-08	1.42E-08	1.42E-08	1.42E-08	1.42E-08	1.4184E-08	40067.8	0.4189
75	1950	1.936	1.42E-08	1.42E-08	1.42E-08	1.42E-08	1.42E-08	1.41702E-08	40028.8	0.41769
76	1975	2	1.37E-08	1.37E-08	1.37E-08	1.37E-08	1.37E-08	1.36692E-08	38613.6	0.41679
77	2000	2	1.36E-08	1.36E-08	1.36E-08	1.36E-08	1.36E-08	1.35666E-08	38323.7	0.41703

3. Sampel C

No	F (Hz)	F (kHz)	C1 (F)	C2 (F)	C3 (F)	C4 (F)	C5 (F)	C rata-rata (F)	€	Kr
1	100	0.1	2.5E-07	2.49E-07	2.49E-07	2.48E-07	2.47E-07	2.48512E-07	702011	0.46236
2	125	0.125	2.08E-07	2.07E-07	2.07E-07	2.07E-07	1.07E-07	1.86998E-07	528192	10.7541
3	150	0.15	1.8E-07	1.8E-07	1.8E-07	1.8E-07	1.79E-07	1.79798E-07	507904	0.42809
4	175	0.176	1.55E-07	1.55E-07	1.55E-07	1.55E-07	1.55E-07	1.54896E-07	437559	0.41986
5	200	0.2	1.45E-07	1.44E-07	1.44E-07	1.44E-07	1.44E-07	1.44258E-07	407508	0.42373
6	225	0.231	1.27E-07	1.27E-07	1.27E-07	1.27E-07	1.27E-07	1.27138E-07	359147	0.42235
7	250	0.25	1.2E-07	1.19E-07	1.19E-07	1.19E-07	1.19E-07	1.19202E-07	336729	0.43209
8	275	0.275	1.1E-07	1.1E-07	1.1E-07	1.1E-07	1.1E-07	1.10299E-07	311554	0.42017
9	300	0.3	1.02E-07	1.02E-07	1.02E-07	1.02E-07	1.02E-07	1.02318E-07	289034	0.41704
10	325	0.324	9.57E-08	9.56E-08	9.55E-08	9.55E-08	9.56E-08	9.55804E-08	270001	0.41731

11	350	0.351	8.96E-08	8.96E-08	8.95E-08	8.95E-08	8.95E-08	8.9525E-08	252895	0.41748
12	375	0.375	8.48E-08	8.48E-08	8.48E-08	8.47E-08	8.47E-08	8.47454E-08	239394	0.41699
13	400	0.4	8.04E-08	8.04E-08	8.04E-08	8.03E-08	8.03E-08	8.03562E-08	226995	0.41678
14	425	0.426	7.65E-08	7.65E-08	7.65E-08	7.65E-08	7.65E-08	7.64666E-08	216007	0.41674
15	450	0.451	7.29E-08	7.29E-08	7.29E-08	7.29E-08	7.29E-08	7.29126E-08	205968	0.41675
16	475	0.476	6.99E-08	6.99E-08	6.99E-08	6.99E-08	6.99E-08	6.99336E-08	197553	0.41682
17	500	0.5	6.76E-08	6.76E-08	6.76E-08	6.76E-08	6.75E-08	6.75674E-08	190868	0.41687
18	525	0.526	6.5E-08	6.5E-08	6.49E-08	6.49E-08	6.49E-08	6.49276E-08	183411	0.41896
19	550	0.55	6.29E-08	6.28E-08	6.28E-08	6.27E-08	6.29E-08	6.2815E-08	177444	0.42004
20	575	0.577	6.09E-08	6.09E-08	6.09E-08	6.09E-08	6.09E-08	6.08684E-08	171945	0.41673
21	600	0.6	5.92E-08	5.92E-08	5.92E-08	5.91E-08	5.91E-08	5.91506E-08	167092	0.41765
22	625	0.625	5.75E-08	5.75E-08	5.76E-08	5.75E-08	5.75E-08	5.75354E-08	162529	0.41683
23	650	0.652	5.57E-08	5.57E-08	5.56E-08	5.56E-08	5.57E-08	5.56684E-08	157255	0.41847
24	675	0.674	5.45E-08	5.44E-08	5.44E-08	5.45E-08	5.45E-08	5.44538E-08	153824	0.41717
25	700	0.698	5.32E-08	5.32E-08	5.32E-08	5.32E-08	5.32E-08	5.3208E-08	150305	0.41677
26	725	0.723	5.19E-08	5.2E-08	5.19E-08	5.19E-08	5.19E-08	5.19332E-08	146704	0.41694
27	750	0.75	5.07E-08	5.07E-08	5.07E-08	5.07E-08	5.08E-08	5.0723E-08	143285	0.41848
28	775	0.779	4.99E-08	4.99E-08	4.99E-08	4.99E-08	4.99E-08	4.99116E-08	140993	0.41689
29	800	0.8	4.92E-08	4.92E-08	4.92E-08	4.92E-08	4.92E-08	4.92078E-08	139005	0.41687
30	825	0.822	4.84E-08	4.84E-08	4.84E-08	4.84E-08	4.84E-08	4.83784E-08	136662	0.4167
31	850	0.845	4.75E-08	4.75E-08	4.75E-08	4.75E-08	4.75E-08	4.74984E-08	134176	0.4169
32	875	0.87	4.67E-08	4.66E-08	4.67E-08	4.67E-08	4.67E-08	4.6658E-08	131802	0.41681
33	900	0.896	4.57E-08	4.57E-08	4.57E-08	4.57E-08	4.57E-08	4.57178E-08	129146	0.41698
34	925	0.923	4.48E-08	4.48E-08	4.48E-08	4.48E-08	4.48E-08	4.4786E-08	126514	0.41719
35	950	0.952	4.38E-08	4.39E-08	4.39E-08	4.39E-08	4.39E-08	4.38674E-08	123919	0.41713
36	975	0.968	4.36E-08	4.36E-08	4.36E-08	4.36E-08	4.36E-08	4.36036E-08	123174	0.41677
37	1000	1	4.26E-08	4.27E-08	4.27E-08	4.27E-08	4.27E-08	4.26556E-08	120496	0.41701
38	1025	1.017	4.23E-08	4.23E-08	4.23E-08	4.23E-08	4.23E-08	4.22766E-08	119425	0.41791
39	1050	1.053	4.14E-08	4.14E-08	4.14E-08	4.14E-08	4.14E-08	4.1408E-08	116972	0.4167
40	1075	1.071	4.09E-08	4.09E-08	4.09E-08	4.09E-08	4.09E-08	4.09358E-08	115638	0.41674
41	1100	1.091	4.04E-08	4.04E-08	4.04E-08	4.04E-08	4.04E-08	4.03962E-08	114114	0.417
42	1125	1.132	3.97E-08	3.96E-08	3.96E-08	3.96E-08	3.96E-08	3.9612E-08	111898	0.41785
43	1150	1.154	3.94E-08	3.95E-08	3.95E-08	3.95E-08	3.95E-08	3.94676E-08	111490	0.4184
44	1175	1.177	3.91E-08	3.91E-08	3.91E-08	3.91E-08	3.91E-08	3.90836E-08	110406	0.41679
45	1200	1.2	3.86E-08	3.85E-08	3.85E-08	3.85E-08	3.85E-08	3.8527E-08	108833	0.41806
46	1225	1.225	3.79E-08	3.78E-08	3.78E-08	3.79E-08	3.79E-08	3.78514E-08	106925	0.41758
47	1250	1.25	3.73E-08	3.73E-08	3.73E-08	3.73E-08	3.73E-08	3.72982E-08	105362	0.41776
48	1275	1.277	3.69E-08	3.7E-08	3.7E-08	3.7E-08	3.7E-08	3.69796E-08	104462	0.41849
49	1300	1.304	3.64E-08	3.64E-08	3.64E-08	3.64E-08	3.65E-08	3.64408E-08	102940	0.41902
50	1325	1.333	3.61E-08	3.61E-08	3.63E-08	3.65E-08	3.66E-08	3.6316E-08	102588	0.49547
51	1350	1.364	3.6E-08	3.6E-08	3.61E-08	3.61E-08	3.61E-08	3.60428E-08	101816	0.42033
52	1375	1.364	3.63E-08	3.64E-08	3.64E-08	3.63E-08	3.63E-08	3.6341E-08	102658	0.41817
53	1400	1.395	3.63E-08	3.63E-08	3.63E-08	3.62E-08	3.62E-08	3.62462E-08	102390	0.41858
54	1425	1.429	3.61E-08	3.6E-08	3.6E-08	3.59E-08	3.6E-08	3.5997E-08	101686	0.42992
55	1450	1.463	3.58E-08	3.59E-08	3.58E-08	3.57E-08	3.57E-08	3.57894E-08	101100	0.42894

56	1475	1.463	3.59E-08	3.59E-08	3.6E-08	3.6E-08	3.6E-08	3.59484E-08	101549	0.41912
57	1500	1.5	3.55E-08	3.54E-08	3.54E-08	3.55E-08	3.55E-08	3.54618E-08	100175	0.41777
58	1525	1.539	3.52E-08	3.52E-08	3.52E-08	3.52E-08	3.52E-08	3.51952E-08	99421.5	0.41747
59	1550	1.539	3.54E-08	3.54E-08	3.54E-08	3.54E-08	3.54E-08	3.54012E-08	100003	0.41714
60	1575	1.579	3.49E-08	3.5E-08	3.5E-08	3.5E-08	3.5E-08	3.49704E-08	98786.4	0.4184
61	1600	1.579	3.51E-08	3.51E-08	3.51E-08	3.52E-08	3.52E-08	3.51334E-08	99246.9	0.41809
62	1625	1.622	3.44E-08	3.44E-08	3.44E-08	3.44E-08	3.44E-08	3.43906E-08	97148.6	0.41718
63	1650	1.667	3.38E-08	3.38E-08	3.38E-08	3.37E-08	3.37E-08	3.37426E-08	95318.1	0.41804
64	1675	1.667	3.38E-08	3.38E-08	3.38E-08	3.38E-08	3.38E-08	3.3778E-08	95418.1	0.41715
65	1700	1.714	3.35E-08	3.35E-08	3.35E-08	3.35E-08	3.35E-08	3.35088E-08	94657.6	0.41762
66	1725	1.714	3.35E-08	3.35E-08	3.35E-08	3.36E-08	3.36E-08	3.35706E-08	94832.2	0.42289
67	1750	1.765	3.33E-08	3.33E-08	3.33E-08	3.33E-08	3.33E-08	3.33082E-08	94091	0.41788
68	1775	1.765	3.32E-08	3.32E-08	3.32E-08	3.33E-08	3.33E-08	3.3261E-08	93957.6	0.42293
69	1800	1.818	3.29E-08	3.29E-08	3.29E-08	3.29E-08	3.29E-08	3.28902E-08	92910.2	0.41843
70	1825	1.818	3.22E-08	3.22E-08	3.22E-08	3.21E-08	3.22E-08	3.21722E-08	90881.9	0.41779
71	1850	1.875	3.23E-08	3.23E-08	3.23E-08	3.23E-08	3.23E-08	3.23222E-08	91305.6	0.41687
72	1875	1.875	3.22E-08	3.22E-08	3.22E-08	3.23E-08	3.23E-08	3.2247E-08	91093.2	0.41821
73	1900	1.875	3.21E-08	3.21E-08	3.21E-08	3.21E-08	3.21E-08	3.20904E-08	90650.8	0.41684
74	1925	1.936	3.16E-08	3.16E-08	3.16E-08	3.17E-08	3.17E-08	3.165E-08	89406.8	0.41773
75	1950	1.936	3.2E-08	3.2E-08	3.2E-08	3.19E-08	3.19E-08	3.19524E-08	90261	0.424
76	1975	2	3.11E-08	3.11E-08	3.11E-08	3.12E-08	3.12E-08	3.11484E-08	87989.8	0.41739
77	2000	2	3.15E-08	3.15E-08	3.15E-08	3.16E-08	3.15E-08	3.15354E-08	89083.1	0.41791

4. Sampel D

No.	F (Hz)	F (kHz)	C1 (F)	C2 (F)	C3 (F)	C4 (F)	C5 (F)	Crata-rata (F)	ϵ	Kr
1	100	0.1	2.64E-07	2.63E-07	2.63E-07	2.63E-07	2.63E-07	2.63016E-07	742983	0.42241
2	125	0.125	2.19E-07	2.19E-07	2.18E-07	2.18E-07	2.17E-07	2.18198E-07	616379	0.45516
3	150	0.15	1.89E-07	1.89E-07	1.89E-07	1.89E-07	1.89E-07	1.88706E-07	533068	0.41713
4	175	0.176	1.69E-07	1.7E-07	1.69E-07	1.7E-07	1.69E-07	1.69438E-07	478638	0.41776
5	200	0.2	1.55E-07	1.56E-07	1.55E-07	1.56E-07	1.56E-07	1.55506E-07	439282	0.41784
6	225	0.231	1.41E-07	1.41E-07	1.41E-07	1.41E-07	1.41E-07	1.4104E-07	398418	0.41773
7	250	0.25	1.33E-07	1.33E-07	1.33E-07	1.33E-07	1.33E-07	1.33116E-07	376034	0.41789
8	275	0.275	1.25E-07	1.25E-07	1.25E-07	1.25E-07	1.25E-07	1.24802E-07	352548	0.41713
9	300	0.3	1.18E-07	1.18E-07	1.18E-07	1.18E-07	1.18E-07	1.17836E-07	332870	0.41828
10	325	0.324	1.11E-07	1.11E-07	1.11E-07	1.11E-07	1.11E-07	1.1114E-07	313955	0.41767
11	350	0.351	1.06E-07	1.05E-07	1.05E-07	1.06E-07	1.05E-07	1.05502E-07	298028	0.41868
12	375	0.375	1.01E-07	1.01E-07	1.01E-07	1.01E-07	1.01E-07	1.00842E-07	284864	0.41732
13	400	0.4	9.67E-08	9.66E-08	9.66E-08	9.65E-08	9.64E-08	9.65754E-08	272812	0.42008
14	425	0.426	9.28E-08	9.28E-08	9.29E-08	9.29E-08	9.28E-08	9.28566E-08	262307	0.41777
15	450	0.451	8.84E-08	8.85E-08	8.84E-08	8.84E-08	8.85E-08	8.84512E-08	249862	0.41755
16	475	0.476	8.55E-08	8.55E-08	8.53E-08	8.51E-08	8.49E-08	8.52584E-08	240843	0.44201
17	500	0.5	8.23E-08	8.22E-08	8.21E-08	8.21E-08	8.21E-08	8.21544E-08	232075	0.4202
18	525	0.526	7.91E-08	7.91E-08	7.91E-08	7.92E-08	7.92E-08	7.9142E-08	223565	0.4174
19	550	0.55	7.7E-08	7.7E-08	7.69E-08	7.7E-08	7.69E-08	7.69584E-08	217397	0.41851
20	575	0.577	7.38E-08	7.41E-08	7.41E-08	7.41E-08	7.41E-08	7.40412E-08	209156	0.42316

21	600	0.6	7.23E-08	7.22E-08	7.21E-08	7.21E-08	7.21E-08	7.21448E-08	203799	0.42172
22	625	0.625	7.04E-08	7.04E-08	7.03E-08	7.03E-08	7.03E-08	7.03366E-08	198691	0.41739
23	650	0.652	6.84E-08	6.85E-08	6.84E-08	6.82E-08	6.82E-08	6.83408E-08	193053	0.42481
24	675	0.674	6.68E-08	6.67E-08	6.67E-08	6.68E-08	6.68E-08	6.6731E-08	188506	0.41836
25	700	0.698	6.46E-08	6.46E-08	6.45E-08	6.45E-08	6.44E-08	6.45138E-08	182242	0.41846
26	725	0.723	6.39E-08	6.39E-08	6.4E-08	6.4E-08	6.4E-08	6.3962E-08	180684	0.41823
27	750	0.75	6.22E-08	6.23E-08	6.23E-08	6.23E-08	6.24E-08	6.22806E-08	175934	0.4186
28	775	0.779	6.03E-08	6.03E-08	6.03E-08	6.05E-08	6.05E-08	6.03604E-08	170510	0.42308
29	800	0.8	5.69E-08	5.7E-08	5.7E-08	5.7E-08	5.7E-08	5.69868E-08	160980	0.41803
30	825	0.822	5.61E-08	5.6E-08	5.58E-08	5.56E-08	5.55E-08	5.579E-08	157599	0.45295
31	850	0.845	5.44E-08	5.44E-08	5.44E-08	5.45E-08	5.44E-08	5.44252E-08	153744	0.41871
32	875	0.87	5.29E-08	5.3E-08	5.31E-08	5.31E-08	5.31E-08	5.30306E-08	149804	0.42757
33	900	0.896	5.19E-08	5.2E-08	5.21E-08	5.21E-08	5.2E-08	5.20246E-08	146962	0.42198
34	925	0.923	5.08E-08	5.07E-08	5.08E-08	5.07E-08	5.07E-08	5.07516E-08	143366	0.41793
35	950	0.952	4.93E-08	4.92E-08	4.92E-08	4.93E-08	4.94E-08	4.92864E-08	139227	0.42234
36	975	0.968	4.81E-08	4.81E-08	4.81E-08	4.8E-08	4.82E-08	4.8111E-08	135907	0.42251
37	1000	1	4.7E-08	4.71E-08	4.72E-08	4.71E-08	4.71E-08	4.71078E-08	133073	0.42055
38	1025	1.017	4.69E-08	4.69E-08	4.68E-08	4.68E-08	4.68E-08	4.68426E-08	132324	0.4186
39	1050	1.053	4.5E-08	4.51E-08	4.51E-08	4.52E-08	4.52E-08	4.51094E-08	127428	0.42577
40	1075	1.071	4.47E-08	4.47E-08	4.47E-08	4.46E-08	4.46E-08	4.46526E-08	126137	0.41696
41	1100	1.091	4.37E-08	4.37E-08	4.36E-08	4.36E-08	4.35E-08	4.36202E-08	123221	0.42939
42	1125	1.132	4.29E-08	4.28E-08	4.28E-08	4.27E-08	4.27E-08	4.2786E-08	120864	0.42203
43	1150	1.154	4.18E-08	4.18E-08	4.19E-08	4.19E-08	4.19E-08	4.18462E-08	118210	0.42322
44	1175	1.177	4.14E-08	4.13E-08	4.12E-08	4.1E-08	4.1E-08	4.1187E-08	116347	0.46505
45	1200	1.2	4.05E-08	4.06E-08	4.07E-08	4.06E-08	4.06E-08	4.06138E-08	114728	0.42188
46	1225	1.225	3.99E-08	3.99E-08	4E-08	4E-08	4E-08	3.99582E-08	112876	0.4179
47	1250	1.25	3.95E-08	3.95E-08	3.95E-08	3.95E-08	3.93E-08	3.94824E-08	111532	0.42614
48	1275	1.277	3.87E-08	3.87E-08	3.86E-08	3.86E-08	3.85E-08	3.86214E-08	109100	0.42032
49	1300	1.304	3.8E-08	3.8E-08	3.8E-08	3.81E-08	3.81E-08	3.80526E-08	107493	0.41869
50	1325	1.333	3.74E-08	3.73E-08	3.73E-08	3.72E-08	3.73E-08	3.72906E-08	105341	0.42017
51	1350	1.364	3.64E-08	3.64E-08	3.64E-08	3.64E-08	3.63E-08	3.6367E-08	102732	0.41741
52	1375	1.364	3.56E-08	3.58E-08	3.59E-08	3.59E-08	3.59E-08	3.5794E-08	101113	0.44469
53	1400	1.395	3.53E-08	3.53E-08	3.53E-08	3.53E-08	3.53E-08	3.5294E-08	99700.6	0.41742
54	1425	1.429	3.46E-08	3.46E-08	3.46E-08	3.46E-08	3.46E-08	3.46122E-08	97774.6	0.41739
55	1450	1.463	3.45E-08	3.45E-08	3.45E-08	3.45E-08	3.45E-08	3.4515E-08	97500	0.41734
56	1475	1.463	3.42E-08	3.42E-08	3.43E-08	4.33E-08	3.43E-08	3.60488E-08	101833	5.01488
57	1500	1.5	3.33E-08	3.33E-08	3.33E-08	3.34E-08	3.33E-08	3.3327E-08	94144.1	0.41748
58	1525	1.539	3.26E-08	3.26E-08	3.26E-08	3.26E-08	3.25E-08	3.25772E-08	92026	0.4181
59	1550	1.539	3.24E-08	3.24E-08	3.24E-08	3.23E-08	3.23E-08	3.23592E-08	91410.2	0.41772
60	1575	1.579	3.18E-08	3.17E-08	3.17E-08	3.17E-08	3.17E-08	3.17476E-08	89682.5	0.41681
61	1600	1.579	3.17E-08	3.17E-08	3.17E-08	3.17E-08	3.17E-08	3.16974E-08	89540.7	0.41684
62	1625	1.622	3.09E-08	3.09E-08	3.09E-08	3.08E-08	3.08E-08	3.08728E-08	87211.3	0.41939
63	1650	1.667	3.02E-08	3.03E-08	3.03E-08	3.03E-08	3.03E-08	3.02864E-08	85554.8	0.42135
64	1675	1.667	3.02E-08	3.02E-08	3.02E-08	3.02E-08	3.02E-08	3.0193E-08	85291	0.41759
65	1700	1.714	2.95E-08	2.95E-08	2.95E-08	2.95E-08	2.95E-08	2.95004E-08	83334.5	0.41772

66	1725	1.714	2.95E-08	2.95E-08	2.94E-08	2.95E-08	2.95E-08	2.94584E-08	83215.8	0.41699
67	1750	1.765	2.87E-08	2.87E-08	2.88E-08	2.88E-08	2.87E-08	2.8749E-08	81211.9	0.41695
68	1775	1.765	2.87E-08	2.87E-08	2.87E-08	2.87E-08	2.87E-08	2.8675E-08	81002.8	0.41695
69	1800	1.818	2.79E-08	2.79E-08	2.79E-08	2.79E-08	2.79E-08	2.79276E-08	78891.5	0.41675
70	1825	1.818	2.79E-08	2.79E-08	2.78E-08	2.78E-08	2.78E-08	2.78536E-08	78682.5	0.41778
71	1850	1.875	2.72E-08	2.72E-08	2.72E-08	2.71E-08	2.71E-08	2.71642E-08	76735	0.41835
72	1875	1.875	2.7E-08	2.7E-08	2.7E-08	2.7E-08	2.7E-08	2.70424E-08	76391	0.4168
73	1900	1.875	2.69E-08	2.7E-08	2.7E-08	2.7E-08	2.7E-08	2.69642E-08	76170.1	0.41799
74	1925	1.936	2.62E-08	2.62E-08	2.62E-08	2.62E-08	2.63E-08	2.62076E-08	74032.8	0.42011
75	1950	1.936	2.62E-08	2.62E-08	2.62E-08	2.62E-08	2.62E-08	2.62246E-08	74080.8	0.41674
76	1975	2	2.55E-08	2.55E-08	2.55E-08	3.55E-08	2.55E-08	2.5703E-08	77692.1	7.27576
77	2000	2	2.54E-08	2.54E-08	2.54E-08	2.54E-08	2.54E-08	2.53948E-08	71736.7	0.41683

f. 50 mL

1. Sampel A

No	F (Hz)	F (kHz)	C1 (F)	C2 (F)	C3 (F)	C4 (F)	C5 (F)	C rata-rata (F)	ε	Kr
1	100	0.1	5.38E-07	5.38E-07	5.37E-07	5.36E-07	5.36E-07	5.3693E-07	1516751	0.4227
2	125	0.125	4.14E-07	4.13E-07	4.13E-07	4.13E-07	4.13E-07	4.13196E-07	1167220	0.418
3	150	0.15	3.35E-07	3.34E-07	3.34E-07	3.34E-07	3.33E-07	3.33874E-07	943147	0.421
4	175	0.1765	2.78E-07	2.78E-07	2.78E-07	2.78E-07	2.77E-07	2.77786E-07	784706	0.4187
5	200	0.2	2.41E-07	2.41E-07	2.41E-07	2.41E-07	2.41E-07	2.40628E-07	679740	0.4168
6	225	0.2308	2.05E-07	2.05E-07	2.05E-07	2.05E-07	2.05E-07	2.0535E-07	580085	0.417
7	250	0.25	1.88E-07	1.88E-07	1.88E-07	1.88E-07	1.88E-07	1.88042E-07	531192	0.4169
8	275	0.2752	1.69E-07	1.69E-07	1.69E-07	1.69E-07	1.69E-07	1.68754E-07	476706	0.4178
9	300	0.3	1.53E-07	1.53E-07	1.53E-07	1.53E-07	1.53E-07	1.53208E-07	432791	0.4171
10	325	0.3243	1.4E-07	1.4E-07	1.4E-07	1.4E-07	1.4E-07	1.39902E-07	395203	0.4167
11	350	0.3509	1.28E-07	1.28E-07	1.28E-07	1.28E-07	1.28E-07	1.28078E-07	361802	0.4176
12	375	0.375	1.18E-07	1.18E-07	1.18E-07	1.18E-07	1.18E-07	1.18306E-07	334198	0.4171
13	400	0.4	1.1E-07	1.1E-07	1.1E-07	1.1E-07	1.1E-07	1.0988E-07	310395	0.4171
14	425	0.4255	1.02E-07	1.02E-07	1.02E-07	1.02E-07	1.02E-07	1.02314E-07	289023	0.4171
15	450	0.4511	9.6E-08	9.59E-08	9.59E-08	9.6E-08	9.59E-08	9.59306E-08	270990	0.4181
16	475	0.4762	9.01E-08	9.01E-08	9.01E-08	9E-08	9E-08	9.0068E-08	254429	0.417
17	500	0.5	8.56E-08	8.56E-08	8.56E-08	8.56E-08	8.56E-08	8.55758E-08	241740	0.4167
18	525	0.5263	8.08E-08	8.08E-08	8.08E-08	8.08E-08	8.08E-08	8.0812E-08	228282	0.4167
19	550	0.5505	7.68E-08	7.68E-08	7.67E-08	7.67E-08	7.67E-08	7.67414E-08	216784	0.4169
20	575	0.5769	7.28E-08	7.28E-08	7.28E-08	7.27E-08	7.27E-08	7.27648E-08	205550	0.4172
21	600	0.6	6.97E-08	6.97E-08	6.97E-08	6.97E-08	6.97E-08	6.96622E-08	196786	0.4167
22	625	0.625	6.65E-08	6.65E-08	6.65E-08	6.65E-08	6.64E-08	6.64926E-08	187832	0.4173
23	650	0.6522	6.35E-08	6.35E-08	6.35E-08	6.35E-08	6.34E-08	6.34538E-08	179248	0.417
24	675	0.6742	6.12E-08	6.12E-08	6.12E-08	6.12E-08	6.12E-08	6.11752E-08	172811	0.4167
25	700	0.6977	5.89E-08	5.89E-08	5.89E-08	5.89E-08	5.89E-08	5.8873E-08	166308	0.4167
26	725	0.7229	5.62E-08	5.62E-08	5.62E-08	5.62E-08	5.62E-08	5.6169E-08	158669	0.4167
27	750	0.75	5.4E-08	5.4E-08	5.4E-08	5.4E-08	5.4E-08	5.39846E-08	152499	0.417
28	775	0.7792	5.18E-08	5.18E-08	5.18E-08	5.18E-08	5.18E-08	5.17882E-08	146294	0.4167
29	800	0.8	5.03E-08	5.03E-08	5.03E-08	5.03E-08	5.03E-08	5.03036E-08	142101	0.4167
30	825	0.8219	4.88E-08	4.88E-08	4.88E-08	4.88E-08	4.88E-08	4.88278E-08	137932	0.4169

31	850	0.8451	4.74E-08	4.74E-08	4.74E-08	4.74E-08	4.74E-08	4.7414E-08	133938	0.4167
32	875	0.8696	4.59E-08	4.59E-08	4.59E-08	4.59E-08	4.58E-08	4.58736E-08	129586	0.417
33	900	0.8955	4.45E-08	4.45E-08	4.45E-08	4.45E-08	4.45E-08	4.44964E-08	125696	0.4167
34	925	0.9231	4.3E-08	4.3E-08	4.3E-08	4.3E-08	4.3E-08	4.30382E-08	121577	0.4167
35	950	0.9524	4.17E-08	4.17E-08	4.17E-08	4.17E-08	4.17E-08	4.17176E-08	117846	0.4169
36	975	0.9678	4.09E-08	4.1E-08	4.1E-08	4.09E-08	4.09E-08	4.09458E-08	115666	0.4167
37	1000	1	3.96E-08	3.96E-08	3.96E-08	3.96E-08	3.96E-08	3.95942E-08	111848	0.4169
38	1025	1.017	3.89E-08	3.89E-08	3.89E-08	3.89E-08	3.89E-08	3.88962E-08	109876	0.4167
39	1050	1.0526	3.75E-08	3.75E-08	3.75E-08	3.75E-08	3.75E-08	3.75304E-08	106018	0.417
40	1075	1.0714	3.72E-08	3.72E-08	3.71E-08	3.7E-08	3.7E-08	3.71048E-08	104816	0.4294
41	1100	1.0909	3.61E-08	3.61E-08	3.61E-08	3.61E-08	3.61E-08	3.6141E-08	102093	0.4167
42	1125	1.1321	3.48E-08	3.48E-08	3.48E-08	3.48E-08	3.48E-08	3.47916E-08	98281.4	0.4168
43	1150	1.1539	3.41E-08	3.41E-08	3.41E-08	3.41E-08	3.41E-08	3.41044E-08	96340.1	0.4167
44	1175	1.1765	3.34E-08	3.34E-08	3.34E-08	3.34E-08	3.34E-08	3.33914E-08	94326	0.417
45	1200	1.2	3.27E-08	3.27E-08	3.27E-08	3.27E-08	3.27E-08	3.27004E-08	92374	0.4167
46	1225	1.2245	3.2E-08	3.2E-08	3.2E-08	3.2E-08	3.2E-08	3.20356E-08	90496	0.4168
47	1250	1.25	3.14E-08	3.14E-08	3.14E-08	3.13E-08	3.13E-08	3.1353E-08	88567.8	0.4168
48	1275	1.2766	3.07E-08	3.07E-08	3.07E-08	3.07E-08	3.06E-08	3.06674E-08	86631.1	0.4229
49	1300	1.3044	2.98E-08	2.98E-08	2.98E-08	2.98E-08	2.98E-08	2.97974E-08	84173.4	0.4167
50	1325	1.3333	2.91E-08	2.91E-08	2.91E-08	2.91E-08	2.91E-08	2.91088E-08	82228.2	0.4167
51	1350	1.3636	2.86E-08	2.86E-08	2.86E-08	2.86E-08	2.86E-08	2.85662E-08	80695.5	0.4167
52	1375	1.3636	2.85E-08	2.85E-08	2.85E-08	2.85E-08	2.85E-08	2.84912E-08	80483.6	0.417
53	1400	1.3954	2.78E-08	2.79E-08	2.79E-08	2.79E-08	2.79E-08	2.78656E-08	78716.4	0.419
54	1425	1.4286	2.72E-08	2.72E-08	2.72E-08	2.72E-08	2.72E-08	2.71674E-08	76744.1	0.4167
55	1450	1.4634	2.65E-08	2.65E-08	2.65E-08	2.65E-08	2.65E-08	2.64938E-08	74841.2	0.4175
56	1475	1.4634	2.64E-08	2.64E-08	2.64E-08	2.64E-08	2.64E-08	2.6368E-08	74485.9	0.4167
57	1500	1.5	2.58E-08	2.58E-08	2.58E-08	2.58E-08	2.58E-08	2.5776E-08	72813.6	0.4167
58	1525	1.5385	2.52E-08	2.52E-08	2.52E-08	2.52E-08	2.52E-08	2.51522E-08	71051.4	0.4167
59	1550	1.5385	2.51E-08	2.51E-08	2.51E-08	2.51E-08	2.51E-08	2.51418E-08	71022	0.4167
60	1575	1.579	2.46E-08	2.46E-08	2.46E-08	2.46E-08	2.46E-08	2.45736E-08	69416.9	0.4168
61	1600	1.579	2.46E-08	2.46E-08	2.46E-08	2.46E-08	2.46E-08	2.45746E-08	69419.8	0.4168
62	1625	1.6216	2.4E-08	2.4E-08	2.4E-08	2.4E-08	2.4E-08	2.39812E-08	67743.5	0.417
63	1650	1.6667	2.34E-08	2.34E-08	2.34E-08	2.34E-08	2.34E-08	2.3414E-08	66141.2	0.4168
64	1675	1.6667	2.34E-08	2.34E-08	2.34E-08	2.34E-08	2.34E-08	2.33802E-08	66045.8	0.4167
65	1700	1.7143	2.28E-08	2.28E-08	2.28E-08	2.28E-08	2.28E-08	2.28118E-08	64440.1	0.4167
66	1725	1.7143	2.28E-08	2.28E-08	2.28E-08	2.28E-08	2.28E-08	2.27934E-08	64388.1	0.4168
67	1750	1.7647	2.22E-08	2.22E-08	2.22E-08	2.22E-08	2.22E-08	2.2197E-08	62703.4	0.4167
68	1775	1.7647	2.22E-08	2.22E-08	2.22E-08	2.22E-08	2.22E-08	2.21972E-08	62704	0.4167
69	1800	1.8182	2.16E-08	2.16E-08	2.16E-08	2.16E-08	2.16E-08	2.16424E-08	61136.7	0.4168
70	1825	1.8182	2.17E-08	2.17E-08	2.17E-08	2.17E-08	2.17E-08	2.1687E-08	61262.7	0.4167
71	1850	1.875	2.11E-08	2.11E-08	2.11E-08	2.11E-08	2.11E-08	2.11224E-08	59667.8	0.4167
72	1875	1.875	2.11E-08	2.11E-08	2.11E-08	2.11E-08	2.11E-08	2.10892E-08	59574	0.4169
73	1900	1.875	2.11E-08	2.11E-08	2.11E-08	2.11E-08	2.11E-08	2.1093E-08	59584.7	0.4167
74	1925	1.9355	2.05E-08	2.05E-08	2.05E-08	2.05E-08	2.05E-08	2.05376E-08	58015.8	0.4167
75	1950	1.9355	2.05E-08	2.05E-08	2.05E-08	2.05E-08	2.05E-08	2.0543E-08	58031.1	0.4168
76	1975	2	2E-08	2E-08	2E-08	2E-08	2E-08	1.99558E-08	56372.3	0.4167
77	2000	2	2E-08	2E-08	2E-08	1.99E-08	1.99E-08	1.99528E-08	56363.8	0.4168

2. Sampel B

No	F (Hz)	F (kHz)	C1 (F)	C2 (F)	C3 (F)	C4 (F)	C5 (F)	C rata-rata (F)	ϵ	Kr
1	100	0.1	5.26E-07	5.26E-07	5.26E-07	5.37E-07	5.27E-07	5.2849E-07	1492910	0.5697
2	125	0.125	4.69E-07	4.7E-07	4.7E-07	4.7E-07	4.7E-07	4.6972E-07	1326893	0.417
3	150	0.15	4.31E-07	4.31E-07	4.31E-07	4.31E-07	4.31E-07	4.31076E-07	1217729	0.4174
4	175	0.1765	4.01E-07	4.01E-07	4.01E-07	4.02E-07	4.02E-07	4.01408E-07	1133921	0.4175
5	200	0.2	3.83E-07	3.83E-07	3.83E-07	3.83E-07	3.83E-07	3.83156E-07	1082362	0.4177
6	225	0.2308	3.63E-07	3.63E-07	3.63E-07	3.63E-07	3.63E-07	3.62906E-07	1025158	0.4173
7	250	0.25	3.53E-07	3.54E-07	3.45E-07	3.45E-07	3.54E-07	3.50414E-07	989870	0.7329
8	275	0.2752	3.43E-07	3.43E-07	3.43E-07	3.43E-07	3.43E-07	3.4316E-07	969379	0.4168
9	300	0.3	3.34E-07	3.34E-07	3.34E-07	3.34E-07	3.34E-07	3.34106E-07	943802	0.4171
10	325	0.3243	3.26E-07	3.26E-07	3.26E-07	3.26E-07	3.26E-07	3.2632E-07	921808	0.4169
11	350	0.3509	3.19E-07	3.19E-07	3.19E-07	3.19E-07	3.19E-07	3.18568E-07	899910	0.4167
12	375	0.375	3.13E-07	3.13E-07	3.13E-07	3.13E-07	3.13E-07	3.12854E-07	883768	0.4169
13	400	0.4	3.08E-07	3.08E-07	3.08E-07	3.08E-07	3.08E-07	3.07664E-07	869107	0.4168
14	425	0.4255	3.03E-07	3.03E-07	3.03E-07	3.03E-07	3.03E-07	3.0299E-07	855904	0.4168
15	450	0.4511	2.99E-07	2.99E-07	2.99E-07	2.99E-07	2.99E-07	2.98882E-07	844299	0.4169
16	475	0.4762	2.95E-07	2.95E-07	2.95E-07	2.95E-07	2.95E-07	2.95138E-07	833723	0.4169
17	500	0.5	2.92E-07	2.92E-07	2.92E-07	2.92E-07	2.92E-07	2.92066E-07	825045	0.4168
18	525	0.5263	2.89E-07	2.89E-07	2.89E-07	2.89E-07	2.89E-07	2.88988E-07	816350	0.4168
19	550	0.5505	2.86E-07	2.86E-07	2.86E-07	2.87E-07	2.87E-07	2.8649E-07	809294	0.4168
20	575	0.5769	2.84E-07	2.84E-07	2.84E-07	2.84E-07	2.84E-07	2.83912E-07	802011	0.4168
21	600	0.6	2.03E-07	2.03E-07	2.02E-07	2.02E-07	2.02E-07	2.02324E-07	571537	0.4369
22	625	0.625	1.93E-07	1.93E-07	1.93E-07	1.93E-07	1.93E-07	1.92982E-07	545147	0.4185
23	650	0.6522	1.87E-07	1.87E-07	1.87E-07	1.87E-07	1.87E-07	1.86718E-07	527452	0.4176
24	675	0.6742	1.83E-07	1.83E-07	1.83E-07	1.83E-07	1.83E-07	1.82996E-07	516938	0.4167
25	700	0.6977	1.8E-07	1.8E-07	1.8E-07	1.8E-07	1.8E-07	1.79622E-07	507407	0.4171
26	725	0.7229	1.75E-07	1.75E-07	1.75E-07	1.74E-07	1.74E-07	1.74504E-07	492949	0.4168
27	750	0.75	1.71E-07	1.71E-07	1.71E-07	1.71E-07	1.71E-07	1.70778E-07	482424	0.4169
28	775	0.7792	1.67E-07	1.67E-07	1.67E-07	1.67E-07	1.67E-07	1.67172E-07	472237	0.4167
29	800	0.8	1.65E-07	1.65E-07	1.65E-07	1.65E-07	1.65E-07	1.64742E-07	465373	0.4168
30	825	0.8219	1.62E-07	1.62E-07	1.62E-07	1.62E-07	1.62E-07	1.62218E-07	458243	0.4168
31	850	0.8451	1.6E-07	1.6E-07	1.6E-07	1.6E-07	1.6E-07	1.59752E-07	451277	0.4167
32	875	0.8696	1.57E-07	1.57E-07	1.57E-07	1.57E-07	1.57E-07	1.57428E-07	444712	0.4168
33	900	0.8955	1.55E-07	1.55E-07	1.55E-07	1.55E-07	1.55E-07	1.54808E-07	437311	0.4169
34	925	0.9231	1.52E-07	1.52E-07	1.52E-07	1.52E-07	1.52E-07	1.52322E-07	430288	0.4167
35	950	0.9524	1.5E-07	1.5E-07	1.5E-07	1.5E-07	1.5E-07	1.49508E-07	422339	0.4167
36	975	0.9678	1.48E-07	1.48E-07	1.48E-07	1.48E-07	1.48E-07	1.48096E-07	418350	0.4168
37	1000	1	1.46E-07	1.46E-07	1.46E-07	1.46E-07	1.46E-07	1.45638E-07	411407	0.4168
38	1025	1.017	1.44E-07	1.44E-07	1.44E-07	1.44E-07	1.44E-07	1.44264E-07	407525	0.4168
39	1050	1.0526	1.42E-07	1.42E-07	1.42E-07	1.42E-07	1.42E-07	1.41696E-07	400271	0.4168
40	1075	1.0714	1.4E-07	1.4E-07	1.4E-07	1.4E-07	1.4E-07	1.40176E-07	395977	0.4167
41	1100	1.0909	1.39E-07	1.39E-07	1.39E-07	1.39E-07	1.39E-07	1.38734E-07	391904	0.4168
42	1125	1.1321	1.36E-07	1.36E-07	1.36E-07	1.36E-07	1.36E-07	1.36104E-07	384475	0.4168
43	1150	1.1539	1.35E-07	1.35E-07	1.35E-07	1.35E-07	1.35E-07	1.3459E-07	380198	0.4168
44	1175	1.1765	1.33E-07	1.33E-07	1.33E-07	1.33E-07	1.33E-07	1.33108E-07	376011	0.4167
45	1200	1.2	1.32E-07	1.32E-07	1.32E-07	1.32E-07	1.32E-07	1.31576E-07	371684	0.4167

46	1225	1.2245	1.3E-07	1.3E-07	1.3E-07	1.3E-07	1.3E-07	1.30034E-07	367328	0.4168
47	1250	1.25	1.29E-07	1.29E-07	1.29E-07	1.28E-07	1.28E-07	1.28506E-07	363011	0.417
48	1275	1.2766	1.27E-07	1.27E-07	1.27E-07	1.27E-07	1.27E-07	1.2696E-07	358644	0.4168
49	1300	1.3044	1.26E-07	1.26E-07	1.26E-07	1.26E-07	1.26E-07	1.2555E-07	354661	0.4167
50	1325	1.3333	1.24E-07	1.24E-07	1.24E-07	1.24E-07	1.24E-07	1.24042E-07	350401	0.4168
51	1350	1.3636	1.23E-07	1.23E-07	1.23E-07	1.23E-07	1.23E-07	1.22592E-07	346305	0.4167
52	1375	1.3636	1.22E-07	1.22E-07	1.22E-07	1.22E-07	1.22E-07	1.2222E-07	345424	0.4168
53	1400	1.3954	1.21E-07	1.21E-07	1.21E-07	1.21E-07	1.21E-07	1.20832E-07	341333	0.4167
54	1425	1.4286	1.19E-07	1.19E-07	1.19E-07	1.19E-07	1.19E-07	1.1906E-07	336328	0.4167
55	1450	1.4634	1.18E-07	1.18E-07	1.18E-07	1.18E-07	1.18E-07	1.17606E-07	332220	0.4167
56	1475	1.4634	1.17E-07	1.17E-07	1.17E-07	1.17E-07	1.17E-07	1.17068E-07	330701	0.4167
57	1500	1.5	1.16E-07	1.16E-07	1.16E-07	1.16E-07	1.16E-07	1.1564E-07	326667	0.4167
58	1525	1.5385	1.14E-07	1.14E-07	1.14E-07	1.14E-07	1.14E-07	1.14404E-07	323175	0.4167
59	1550	1.5385	1.14E-07	1.14E-07	1.14E-07	1.14E-07	1.14E-07	1.14142E-07	322435	0.4167
60	1575	1.579	1.13E-07	1.13E-07	1.13E-07	1.13E-07	1.13E-07	1.1282E-07	318701	0.4167
61	1600	1.579	1.13E-07	1.13E-07	1.13E-07	1.13E-07	1.13E-07	1.12692E-07	318339	0.4167
62	1625	1.6216	1.11E-07	1.11E-07	1.11E-07	1.11E-07	1.11E-07	1.11336E-07	314508	0.4167
63	1650	1.6667	1.1E-07	1.1E-07	1.1E-07	1.1E-07	1.1E-07	1.09844E-07	310294	0.4169
64	1675	1.6667	1.1E-07	1.1E-07	1.1E-07	1.1E-07	1.1E-07	1.09638E-07	309712	0.4167
65	1700	1.7143	1.08E-07	1.08E-07	1.08E-07	1.08E-07	1.08E-07	1.0834E-07	306045	0.4167
66	1725	1.7143	1.08E-07	1.08E-07	1.08E-07	1.08E-07	1.08E-07	1.08154E-07	305520	0.4167
67	1750	1.7647	1.07E-07	1.07E-07	1.07E-07	1.07E-07	1.07E-07	1.06856E-07	301853	0.4167
68	1775	1.7647	1.07E-07	1.07E-07	1.07E-07	1.07E-07	1.07E-07	1.06722E-07	301475	0.4167
69	1800	1.8182	1.05E-07	1.05E-07	1.05E-07	1.05E-07	1.05E-07	1.05428E-07	297819	0.4167
70	1825	1.8182	1.05E-07	1.05E-07	1.05E-07	1.05E-07	1.05E-07	1.05354E-07	297610	0.4168
71	1850	1.875	1.04E-07	1.04E-07	1.04E-07	1.04E-07	1.04E-07	1.03988E-07	293751	0.4167
72	1875	1.875	1.04E-07	1.04E-07	1.04E-07	1.04E-07	1.04E-07	1.0373E-07	293023	0.4167
73	1900	1.875	1.04E-07	1.04E-07	1.03E-07	1.03E-07	1.03E-07	1.03492E-07	292350	0.4167
74	1925	1.9355	1.02E-07	1.02E-07	1.02E-07	1.02E-07	1.02E-07	1.02034E-07	288232	0.4168
75	1950	1.9355	1.02E-07	1.02E-07	1.02E-07	1.02E-07	1.02E-07	1.01956E-07	288011	0.4167
76	1975	2	1.01E-07	1.01E-07	1.01E-07	1.01E-07	1.01E-07	1.00578E-07	284119	0.4168
77	2000	2	1E-07	1E-07	1E-07	1E-07	1E-07	1.00438E-07	283723	0.4175

3. Sampel C

No	F (Hz)	F (KHz)	C1 (F)	C2 (F)	C3 (F)	C4 (F)	C5 (F)	C rata-rata (F)	ε	Kr
1	100	0.1	3.6E-07	3.6E-07	3.59E-07	3.58E-07	3.56E-07	3.58694E-07	1013260	0.4529
2	125	0.125	2.75E-07	2.75E-07	2.75E-07	2.75E-07	2.74E-07	2.74978E-07	776774	0.4207
3	150	0.15	2.26E-07	2.26E-07	2.25E-07	2.25E-07	2.25E-07	2.255E-07	637006	0.4241
4	175	0.1765	1.9E-07	1.9E-07	1.9E-07	1.89E-07	1.89E-07	1.89614E-07	535633	0.4194
5	200	0.2	1.67E-07	1.67E-07	1.66E-07	1.66E-07	1.66E-07	1.66502E-07	470345	0.4188
6	225	0.2308	1.43E-07	1.43E-07	1.43E-07	1.43E-07	1.43E-07	1.43324E-07	404870	0.417
7	250	0.25	1.32E-07	1.32E-07	1.32E-07	1.32E-07	1.31E-07	1.31598E-07	371746	0.4174
8	275	0.2752	1.2E-07	1.2E-07	1.2E-07	1.2E-07	1.19E-07	1.19524E-07	337638	0.4169
9	300	0.3	1.1E-07	1.1E-07	1.1E-07	1.1E-07	1.1E-07	1.0969E-07	309859	0.4168
10	325	0.3243	1.01E-07	1.01E-07	1.01E-07	1.01E-07	1.01E-07	1.01204E-07	285887	0.4174

11	350	0.3509	9.36E-08	9.35E-08	9.35E-08	9.35E-08	9.35E-08	9.35E-08	9.35108E-08	264155	0.4169
12	375	0.375	8.79E-08	8.78E-08	8.78E-08	8.78E-08	8.78E-08	8.78E-08	8.78354E-08	248123	0.4167
13	400	0.4	8.25E-08	8.24E-08	8.24E-08	8.24E-08	8.24E-08	8.24E-08	8.24244E-08	232837	0.4169
14	425	0.4255	7.75E-08	7.75E-08	7.75E-08	7.73E-08	7.73E-08	7.73E-08	7.74234E-08	218710	0.4187
15	450	0.4511	7.98E-08	7.98E-08	7.99E-08	7.99E-08	7.99E-08	7.99E-08	7.98734E-08	225631	0.4176
16	475	0.4762	7.6E-08	7.6E-08	7.6E-08	7.6E-08	7.6E-08	7.6E-08	7.59828E-08	214641	0.4168
17	500	0.5	7.26E-08	7.26E-08	7.26E-08	7.26E-08	7.26E-08	7.25E-08	7.25692E-08	204998	0.4168
18	525	0.5263	6.9E-08	6.9E-08	6.9E-08	6.9E-08	6.9E-08	6.9E-08	6.90318E-08	195005	0.4168
19	550	0.5505	6.61E-08	6.61E-08	6.61E-08	6.61E-08	6.61E-08	6.61E-08	6.61014E-08	186727	0.417
20	575	0.5769	6.31E-08	6.31E-08	6.31E-08	6.31E-08	6.31E-08	6.31E-08	6.31066E-08	178267	0.4169
21	600	0.6	6.07E-08	6.07E-08	6.07E-08	6.07E-08	6.07E-08	6.07E-08	6.06878E-08	171434	0.4167
22	625	0.625	5.83E-08	5.83E-08	5.83E-08	5.83E-08	5.83E-08	5.83E-08	5.8317E-08	164737	0.4167
23	650	0.6522	5.6E-08	5.6E-08	5.6E-08	5.6E-08	5.6E-08	5.6E-08	5.59814E-08	158140	0.4169
24	675	0.6742	5.42E-08	5.42E-08	5.42E-08	5.42E-08	5.42E-08	5.42E-08	5.4205E-08	153121	0.4167
25	700	0.6977	5.22E-08	5.22E-08	5.22E-08	5.22E-08	5.22E-08	5.22E-08	5.2238E-08	147565	0.4167
26	725	0.7229	5.05E-08	5.06E-08	5.06E-08	5.06E-08	5.06E-08	5.06E-08	5.05652E-08	142840	0.4169
27	750	0.75	4.89E-08	4.89E-08	4.89E-08	4.89E-08	4.89E-08	4.89E-08	4.88988E-08	138132	0.4169
28	775	0.7792	4.72E-08	4.71E-08	4.71E-08	4.71E-08	4.71E-08	4.71E-08	4.71384E-08	133159	0.4169
29	800	0.8	4.6E-08	4.6E-08	4.6E-08	4.6E-08	4.6E-08	4.6E-08	4.59714E-08	129863	0.4168
30	825	0.8219	4.49E-08	4.49E-08	4.49E-08	4.49E-08	4.49E-08	4.49E-08	4.48906E-08	126810	0.4167
31	850	0.8451	4.37E-08	4.36E-08	4.36E-08	4.36E-08	4.36E-08	4.36E-08	4.36238E-08	123231	0.422
32	875	0.8696	4.24E-08	4.24E-08	4.24E-08	4.24E-08	4.24E-08	4.24E-08	4.2376E-08	119706	0.4168
33	900	0.8955	4.13E-08	4.13E-08	4.13E-08	4.13E-08	4.13E-08	4.13E-08	4.1287E-08	116630	0.4167
34	925	0.9231	4.01E-08	4.01E-08	4.01E-08	4.01E-08	4.01E-08	4.01E-08	4.0106E-08	113294	0.4171
35	950	0.9524	3.89E-08	3.89E-08	3.89E-08	3.89E-08	3.89E-08	3.89E-08	3.8911E-08	109918	0.4169
36	975	0.9678	3.84E-08	3.84E-08	3.84E-08	3.84E-08	3.84E-08	3.84E-08	3.83874E-08	108439	0.4167
37	1000	1	3.73E-08	3.73E-08	3.73E-08	3.73E-08	3.73E-08	3.73E-08	3.72578E-08	105248	0.4167
38	1025	1.017	3.67E-08	3.67E-08	3.67E-08	3.67E-08	3.67E-08	3.67E-08	3.66776E-08	103609	0.4179
39	1050	1.0526	3.56E-08	3.56E-08	3.56E-08	3.56E-08	3.56E-08	3.56E-08	3.55606E-08	100454	0.4167
40	1075	1.0714	3.49E-08	3.49E-08	3.49E-08	3.49E-08	3.49E-08	3.49E-08	3.4903E-08	98596	0.4168
41	1100	1.0909	3.43E-08	3.43E-08	3.43E-08	3.43E-08	3.43E-08	3.43E-08	3.4323E-08	96957.6	0.4167
42	1125	1.1321	3.32E-08	3.32E-08	3.32E-08	3.32E-08	3.32E-08	3.32E-08	3.32074E-08	93806.2	0.4168
43	1150	1.1539	3.26E-08	3.26E-08	3.26E-08	3.26E-08	3.26E-08	3.26E-08	3.25644E-08	91989.8	0.4167
44	1175	1.1765	3.2E-08	3.2E-08	3.2E-08	3.2E-08	3.2E-08	3.2E-08	3.20288E-08	90476.8	0.4168
45	1200	1.2	3.14E-08	3.14E-08	3.14E-08	3.14E-08	3.14E-08	3.14E-08	3.13888E-08	88668.9	0.4168
46	1225	1.2245	3.09E-08	3.09E-08	3.09E-08	3.09E-08	3.09E-08	3.08E-08	3.08546E-08	87159.9	0.4167
47	1250	1.25	3.02E-08	3.02E-08	3.02E-08	3.02E-08	3.02E-08	3.02E-08	3.02074E-08	85331.6	0.4168
48	1275	1.2766	2.96E-08	2.96E-08	2.96E-08	2.96E-08	2.96E-08	2.96E-08	2.9562E-08	83508.5	0.4167
49	1300	1.3044	2.89E-08	2.89E-08	2.89E-08	2.89E-08	2.89E-08	2.89E-08	2.89342E-08	81735	0.417
50	1325	1.3333	2.83E-08	2.83E-08	2.83E-08	2.83E-08	2.83E-08	2.83E-08	2.83014E-08	79947.5	0.4169
51	1350	1.3636	2.77E-08	2.77E-08	2.77E-08	2.77E-08	2.77E-08	2.77E-08	2.7698E-08	78242.9	0.4176
52	1375	1.3636	2.77E-08	2.77E-08	2.77E-08	2.77E-08	2.77E-08	2.77E-08	2.76664E-08	78153.7	0.4167
53	1400	1.3954	2.7E-08	2.7E-08	2.7E-08	2.7E-08	2.7E-08	2.7E-08	0.000000027	76271.2	0.4167
54	1425	1.4286	2.64E-08	2.64E-08	2.64E-08	2.64E-08	2.64E-08	2.64E-08	2.63866E-08	74538.4	0.4167
55	1450	1.4634	2.58E-08	2.58E-08	2.58E-08	2.58E-08	2.58E-08	2.58E-08	2.5781E-08	72827.7	0.4168
56	1475	1.4634	2.57E-08	2.57E-08	2.57E-08	2.57E-08	2.57E-08	2.57E-08	2.571E-08	72627.1	0.4167
57	1500	1.5	2.58E-08	2.58E-08	2.58E-08	2.58E-08	2.58E-08	2.58E-08	2.5815E-08	72923.7	0.4169
58	1525	1.5385	2.52E-08	2.52E-08	2.52E-08	2.52E-08	2.52E-08	2.52E-08	2.51682E-08	71096.6	0.4167
59	1550	1.5385	2.45E-08	2.45E-08	2.45E-08	2.45E-08	2.45E-08	2.45E-08	2.4483E-08	69161	0.4169
60	1575	1.579	2.44E-08	2.44E-08	2.44E-08	2.44E-08	2.44E-08	2.44E-08	2.43904E-08	68899.4	0.4168

61	1600	1.579	2.38E-08	2.38E-08	2.38E-08	2.37E-08	2.38E-08	2.37516E-08	67094.9	0.4167
62	1625	1.6216	2.37E-08	2.37E-08	2.37E-08	2.37E-08	2.37E-08	2.36712E-08	66867.8	0.4167
63	1650	1.6667	2.31E-08	2.31E-08	2.3E-08	2.3E-08	2.3E-08	2.30496E-08	65111.9	0.4168
64	1675	1.6667	2.25E-08	2.25E-08	2.24E-08	2.24E-08	2.24E-08	2.24492E-08	63415.8	0.4167
65	1700	1.7143	2.17E-08	2.17E-08	2.17E-08	2.17E-08	2.17E-08	2.1715E-08	61341.8	0.4168
66	1725	1.7143	2.17E-08	2.16E-08	2.16E-08	2.16E-08	2.16E-08	2.16458E-08	61146.3	0.4167
67	1750	1.7647	2.1E-08	2.1E-08	2.1E-08	2.1E-08	2.1E-08	2.1031E-08	59409.6	0.4168
68	1775	1.7647	2.1E-08	2.1E-08	2.09E-08	2.09E-08	2.09E-08	2.09482E-08	59175.7	0.4168
69	1800	1.8182	2.03E-08	2.03E-08	2.03E-08	2.03E-08	2.03E-08	2.03176E-08	57394.4	0.4167
70	1825	1.8182	2.03E-08	2.03E-08	2.03E-08	2.03E-08	2.03E-08	2.03076E-08	57366.1	0.4167
71	1850	1.875	1.97E-08	1.97E-08	1.97E-08	1.97E-08	1.97E-08	1.97274E-08	55727.1	0.4168
72	1875	1.875	1.97E-08	1.97E-08	1.97E-08	1.97E-08	1.97E-08	1.96842E-08	55605.1	0.4167
73	1900	1.875	1.97E-08	1.97E-08	1.97E-08	1.97E-08	1.97E-08	1.96628E-08	55544.6	0.4167
74	1925	1.9355	1.9E-08	1.9E-08	1.9E-08	1.9E-08	1.9E-08	1.90414E-08	53789.3	0.4169
75	1950	1.9355	1.9E-08	1.9E-08	1.9E-08	1.9E-08	1.9E-08	1.8982E-08	53621.5	0.4168
76	1975	2	1.84E-08	1.84E-08	1.84E-08	1.84E-08	1.84E-08	1.83894E-08	51947.5	0.4168
77	2000	2	1.84E-08	1.84E-08	1.84E-08	1.83E-08	1.83E-08	1.8351E-08	51839	0.4168

4. Sampel D

No	F (Hz)	F (kHz)	C1 (F)	C2 (F)	C3 (F)	C4 (F)	C5 (F)	Crata-rata (F)	ε	Kr
1	100	0.1	3.17E-07	3.16E-07	3.16E-07	3.16E-07	3.15E-07	3.1603E-07	892740	0.4286
2	125	0.125	2.46E-07	2.46E-07	2.46E-07	2.45E-07	2.44E-07	2.4552E-07	693565	0.4478
3	150	0.15	1.98E-07	1.98E-07	1.98E-07	1.98E-07	1.97E-07	1.9784E-07	558870	0.4226
4	175	0.1765	1.68E-07	1.68E-07	1.68E-07	1.69E-07	1.69E-07	1.6831E-07	475475	0.4337
5	200	0.2	1.54E-07	1.54E-07	1.54E-07	1.53E-07	1.54E-07	1.5369E-07	434169	0.4242
6	225	0.2308	1.39E-07	1.39E-07	1.38E-07	1.39E-07	1.38E-07	1.3855E-07	391407	0.4175
7	250	0.25	1.29E-07	1.29E-07	1.29E-07	1.3E-07	1.3E-07	1.2927E-07	365192	0.4268
8	275	0.2752	1.23E-07	1.23E-07	1.22E-07	1.23E-07	1.23E-07	1.2264E-07	346458	0.4284
9	300	0.3	1.14E-07	1.14E-07	1.14E-07	1.13E-07	1.13E-07	1.1346E-07	320508	0.4223
10	325	0.3243	1.07E-07	1.07E-07	1.07E-07	1.07E-07	1.07E-07	1.0667E-07	301333	0.4169
11	350	0.3509	1.01E-07	1.01E-07	1.01E-07	1.01E-07	1.01E-07	1.0088E-07	284972	0.4186
12	375	0.375	9.61E-08	9.61E-08	9.61E-08	9.6E-08	9.59E-08	9.6033E-08	271280	0.4188
13	400	0.4	9.13E-08	9.12E-08	9.08E-08	9.1E-08	9.07E-08	9.0983E-08	257016	0.4307
14	425	0.4255	8.64E-08	8.63E-08	8.63E-08	8.63E-08	8.62E-08	8.6303E-08	243794	0.4173
15	450	0.4511	8.19E-08	8.18E-08	8.18E-08	8.18E-08	8.18E-08	8.1794E-08	231059	0.4172
16	475	0.4762	7.86E-08	7.85E-08	7.85E-08	7.84E-08	7.84E-08	7.8474E-08	221679	0.4195
17	500	0.5	7.57E-08	7.57E-08	7.57E-08	7.58E-08	7.59E-08	7.5767E-08	214032	0.4188
18	525	0.5263	7.43E-08	7.45E-08	7.48E-08	7.48E-08	7.48E-08	7.4624E-08	210805	0.4379
19	550	0.5505	7.3E-08	7.32E-08	7.33E-08	7.34E-08	7.35E-08	7.3276E-08	206994	0.4302
20	575	0.5769	7.12E-08	7.11E-08	7.1E-08	7.09E-08	7.09E-08	7.1003E-08	200576	0.4252
21	600	0.6	6.87E-08	6.87E-08	6.87E-08	6.87E-08	6.86E-08	6.8678E-08	194007	0.4169
22	625	0.625	6.61E-08	6.62E-08	6.62E-08	6.62E-08	6.62E-08	6.6168E-08	186916	0.4171
23	650	0.6522	6.38E-08	6.37E-08	6.36E-08	6.36E-08	6.37E-08	6.3685E-08	174253	3.295
24	675	0.6742	6.16E-08	6.16E-08	6.15E-08	6.17E-08	6.19E-08	6.1655E-08	174169	0.4294
25	700	0.6977	6.02E-08	6.02E-08	6.02E-08	6.03E-08	6.04E-08	6.0227E-08	170133	0.4213
26	725	0.7229	6.09E-08	6.1E-08	6.11E-08	6.09E-08	6.08E-08	6.0913E-08	172073	0.4233
27	750	0.75	5.96E-08	5.95E-08	5.91E-08	5.9E-08	5.91E-08	5.9252E-08	167379	0.4565
28	775	0.7792	5.67E-08	5.7E-08	5.71E-08	5.7E-08	5.75E-08	5.7047E-08	161150	0.4718
29	800	0.8	5.47E-08	5.48E-08	5.47E-08	5.45E-08	5.42E-08	5.4582E-08	154188	0.466
30	825	0.8219	5.35E-08	5.34E-08	5.31E-08	5.31E-08	5.3E-08	5.3217E-08	150332	0.4615
31	850	0.8451	4.68E-08	4.68E-08	4.68E-08	4.68E-08	4.67E-08	4.6804E-08	132215	0.4188
32	875	0.8696	4.55E-08	4.55E-08	4.55E-08	4.55E-08	4.55E-08	4.55274E-08	128608	0.4169
33	900	0.8955	4.41E-08	4.4E-08	4.4E-08	4.4E-08	4.4E-08	4.40214E-08	124354	0.4193
34	925	0.9231	4.28E-08	4.28E-08	4.27E-08	4.27E-08	4.26E-08	4.2715E-08	120666	0.4194
35	950	0.9524	4.13E-08	4.12E-08	4.12E-08	4.12E-08	4.12E-08	4.1225E-08	116455	0.4198
36	975	0.9678	4.09E-08	4.09E-08	4.09E-08	4.09E-08	4.09E-08	4.0904E-08	115548	0.4171
37	1000	1	3.91E-08	3.91E-08	3.91E-08	3.91E-08	3.91E-08	3.9084E-08	110407	0.4177
38	1025	1.017	3.81E-08	3.8E-08	3.8E-08	3.79E-08	3.79E-08	3.79814E-08	107292	0.4245
39	1050	1.0526	3.58E-08	3.58E-08	3.58E-08	3.58E-08	3.58E-08	3.57912E-08	101105	0.4176
40	1075	1.0714	3.48E-08	3.48E-08	3.48E-08	3.48E-08	3.47E-08	3.47822E-08	98254.8	0.4186
41	1100	1.0909	3.32E-08	3.32E-08	3.32E-08	3.32E-08	3.32E-08	3.3211E-08	93816.4	0.4182
42	1125	1.1321	3.13E-08	3.12E-08	3.12E-08	3.11E-08	3.11E-08	3.11836E-08	88089.3	0.4245
43	1150	1.1539	2.96E-08	2.95E-08	2.95E-08	2.95E-08	2.95E-08	2.95126E-08	83368.9	0.4209
44	1175	1.1765	2.86E-08	2.86E-08	2.86E-08	2.86E-08	2.86E-08	2.85694E-08	80704.5	0.4168
45	1200	1.2	2.57E-08	2.56E-08	2.56E-08	2.55E-08	2.55E-08	2.55794E-08	72258.2	0.4317
46	1225	1.2245	2.58E-08	2.58E-08	2.59E-08	2.59E-08	2.59E-08	2.58472E-08	73014.7	0.4266
47	1250	1.25	2.56E-08	2.55E-08	2.55E-08	2.55E-08	2.55E-08	2.55238E-08	72101.1	0.4178
48	1275	1.2766	2.47E-08	2.46E-08	2.46E-08	2.46E-08	2.46E-08	2.4625E-08	69562.1	0.4193
49	1300	1.3044	2.37E-08	2.37E-08	2.37E-08	2.36E-08	2.37E-08	2.36684E-08	66859.9	0.4197
50	1325	1.3333	2.27E-08	2.28E-08	2.28E-08	2.28E-08	2.28E-08	2.2761E-08	64296.6	0.4173

51	1350	1.3636	2.18E-08	2.16E-08	2.16E-08	2.17E-08	2.16E-08	2.1631E-08	61104.5	0.4616
52	1375	1.3636	2.16E-08	2.16E-08	2.16E-08	2.16E-08	2.16E-08	2.15832E-08	60969.5	0.4184
53	1400	1.3954	2.23E-08	2.22E-08	2.22E-08	2.22E-08	2.22E-08	2.22262E-08	62785.9	0.4249
54	1425	1.4286	2.11E-08	2.11E-08	2.11E-08	2.11E-08	2.11E-08	2.1096E-08	59593.2	0.4207
55	1450	1.4634	2.02E-08	2.02E-08	2.02E-08	2.03E-08	2.03E-08	2.02504E-08	57204.5	0.4175
56	1475	1.4634	1.99E-08	1.99E-08	1.99E-08	1.99E-08	1.99E-08	1.98628E-08	56109.6	0.4169
57	1500	1.5	1.94E-08	1.94E-08	1.94E-08	1.95E-08	1.95E-08	1.94348E-08	54900.6	0.4187
58	1525	1.5385	1.87E-08	1.87E-08	1.88E-08	1.89E-08	1.89E-08	1.87822E-08	53057.1	0.4559
59	1550	1.5385	1.86E-08	1.86E-08	1.86E-08	1.86E-08	1.86E-08	1.86148E-08	52584.2	0.4168
60	1575	1.579	1.86E-08	1.85E-08	1.85E-08	1.85E-08	1.85E-08	1.85046E-08	52272.9	0.4265
61	1600	1.579	1.83E-08	1.83E-08	1.82E-08	1.82E-08	1.82E-08	1.82286E-08	51493.2	0.4276
62	1625	1.6216	1.78E-08	1.78E-08	1.78E-08	1.78E-08	1.78E-08	1.77584E-08	50165	0.417
63	1650	1.6667	1.71E-08	1.71E-08	1.71E-08	1.71E-08	1.71E-08	1.7094E-08	48288.1	0.419
64	1675	1.6667	1.69E-08	1.69E-08	1.68E-08	1.68E-08	1.68E-08	1.68486E-08	47594.9	0.4181
65	1700	1.7143	1.64E-08	1.64E-08	1.64E-08	1.64E-08	1.64E-08	1.63872E-08	46291.5	0.417
66	1725	1.7143	1.63E-08	1.63E-08	1.63E-08	1.63E-08	1.63E-08	1.63186E-08	46097.7	0.4179
67	1750	1.7647	1.58E-08	1.58E-08	1.58E-08	1.58E-08	1.58E-08	1.5789E-08	44601.7	0.4188
68	1775	1.7647	1.58E-08	1.58E-08	1.58E-08	1.58E-08	1.58E-08	1.57842E-08	44588.1	0.4169
69	1800	1.8182	1.54E-08	1.54E-08	1.54E-08	1.54E-08	1.54E-08	1.54292E-08	43585.3	0.4175
70	1825	1.8182	1.51E-08	1.51E-08	1.51E-08	1.51E-08	1.51E-08	1.51136E-08	42693.8	0.4172
71	1850	1.875	1.48E-08	1.48E-08	1.58E-08	1.48E-08	1.48E-08	1.49836E-08	42326.6	1.4054
72	1875	1.875	1.48E-08	1.48E-08	1.48E-08	1.48E-08	1.48E-08	1.48128E-08	41844.1	0.4167
73	1900	1.875	1.48E-08	1.48E-08	1.48E-08	1.48E-08	1.48E-08	1.48266E-08	41883.1	0.4171
74	1925	1.9355	1.43E-08	1.43E-08	1.42E-08	1.42E-08	1.43E-08	1.42526E-08	40261.6	0.4193
75	1950	1.9355	1.41E-08	1.41E-08	1.41E-08	1.41E-08	1.41E-08	1.40958E-08	39818.6	0.4169
76	1975	2	1.37E-08	1.37E-08	1.37E-08	1.37E-08	1.37E-08	1.3683E-08	38652.5	0.4179
77	2000	2	1.36E-08	1.36E-08	1.36E-08	1.36E-08	1.36E-08	1.35856E-08	38377.4	0.417