

# **THE INFLUENCE OF CHINA'S AND THE UNITED STATES' MACROECONOMIC VARIABLES ON RUPIAH EXCHANGE RATE**

(Study at International Monetary Fund and Federal Reserve Bank 2009-2018)

## **UNDERGRADUATE THESIS**

**Presented as Requirement to Take Undergraduate Thesis Examination at  
Faculty of Administrative Science Universitas Brawijaya**

**ADINDA BANI MEGAWATI  
NIM. 155030200111081**



**UNIVERSITAS BRAWIJAYA  
FACULTY OF ADMINISTRATIVE SCIENCE  
BUSINESS ADMINISTRATION DEPARTMENT  
BUSINESS ADMINISTRATION STUDY PROGRAM  
INTERNATIONAL BUSINESS  
MALANG  
2019**

## MOTTO

*“A smooth sea never made a skilled sailor.”*  
**(Franklin D. Roosevelt)**

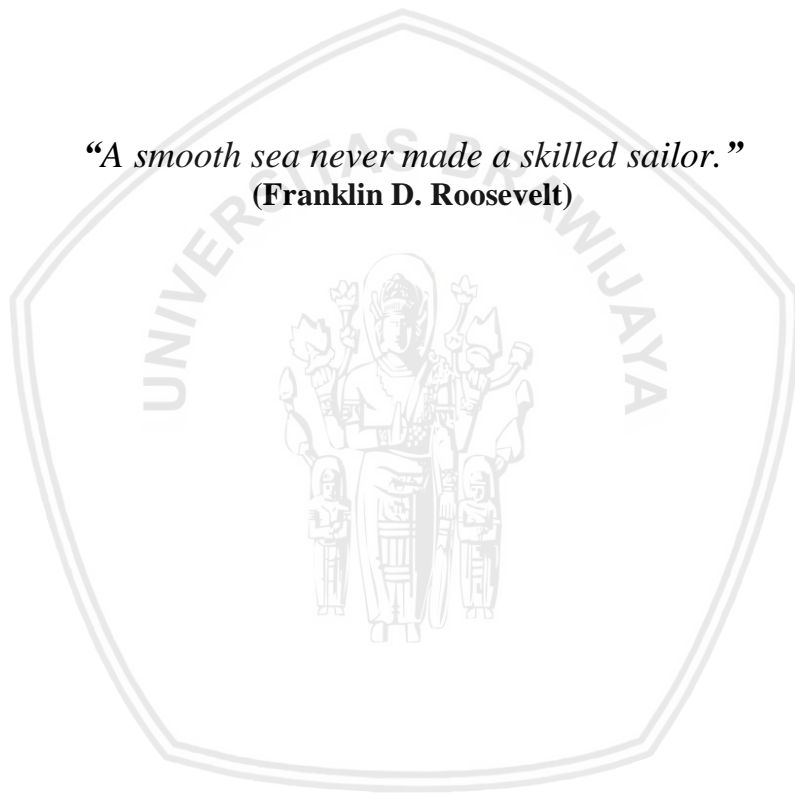

**APPROVAL SHEET**

Title : **The Influence of China's and The United States' Macroeconomic Variables on Rupiah Exchange Rate**  
(Study at International Monetary Fund and Federal Reserve Bank 2009-2018)

Created by : Adinda Bani Megawati

Student ID : 155030200111081

Faculty : Administrative Science

Major : Business Administration

Concentration : International Business

Malang, 22 May 2019

Supervisor

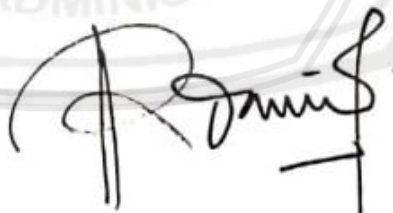

**Cacik Rut Damayanti, S.Sos., M.Prof.Acc., D.BA**

**NIP. 19790908 200501 2 001**

**BOARD OF EXAMINERS APPROVAL**

This is to certify that the undergraduate thesis belongs to Adinda Bani Megawati has been examined and approved by the board of examiners as a form prerequisite Bachelor Degree of Business Administration, at:

Day : Wednesday

Date : 19 June 2019

Time : 09.00

Title : The Influence of China's and The United States' Macroeconomic Variables on Rupiah Exchange Rate (Study at International Monetary Fund and Federal Reserve Bank 2009-2018)

**Has Successfully PASSED**

Board of Examiners,

Head of Examiners,

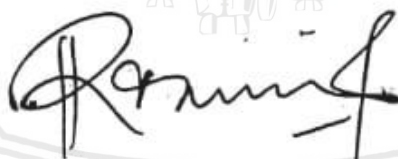

**Cacik Rut Damavanti, S.Sos., M.Prof.Acc., D.BA**

NIP 19790908 200501 2 001

Examiners



**Nila Firdausi Nuzula, Ph.D**

NIP 197305302003122001

Examiners



**Sri Sulasmiyati, S.Sos. MAP**

NIP. 197304202005022001

## STATEMENT OF ORIGINALITY

I declare in truth, as far as I know that in these undergraduate thesis, there are no scientific works which have been submitted by other parties to obtain works or opinions that have been written or published by others in the past time except those which are quoted and mentioned in the source of citations and bibliography or references page.

If there is any element of plagiarism, I am willing to take the risks that my academic degree of bachelor will be aborted, and this minor thesis will be instantly unpublished. I am also ready to be punished according to applicable law based on Indonesia Constitution (UUD) No. 20, Year of 2003, Verse 2 of Article 25 and Article 70.

Malang, 22 May 2019



TERAI  
EMPEL  
B9FAFF707512825  
000  
RIBU RUPIAH  
**Adinda Bani Megawati**  
155030200111081

## SUMMARY

Adinda Bani Megawati, 2019, **The Influence of China's and The United States' Macroeconomic Variables on Rupiah Exchange Rate** (Study at International Monetary Fund and Federal Reserve Bank 2009-2018), Cacik Rut Damayanti, S.Sos., M.Prof.Acc., D.BA, 110 Pages + xiii.

This world is surrounded by more than 190 countries and each of them has their own strengths and weaknesses in many different fields. One of the forms of socializing between the countries itself would be doing international trade and the process of trading certainly uses payments. Every payment usually requires money. The use of money in the international transaction is determined using the agreed-upon currency, often called exchange rate. For the first time in the past 3 years, Indonesian rupiah exchange rate reaches the highest level. At the same time, a trade war that occurred between China and the United States. The purpose of this research is to examine the influence of China's and the United States' macroeconomic variables, which are net exports, economic growth and inflation towards Indonesian rupiah exchange rate by using multiple linear regression analysis. This research uses quarterly data from quarter I 2009 to quarter II 2018 with 76 samples of data time series for each independent variable.

The results of this research indicates that; 1) China's and United States' net exports partially have significant influence towards rupiah exchange rates; 2) China's and United States' economic growth partially has significant influence towards rupiah exchange rates; 3) China's and United States' inflation partially have significant influence towards rupiah exchange rates; 4) Net exports, economic growth and inflation of China and United States simultaneously influencing rupiah exchange rates. The findings in this research are expected to be able to predict the fluctuation of Indonesian rupiah exchange rate.

Keywords: net exports, economic growth, inflation, exchange rate

## RINGKASAN

Adinda Bani Megawati, 2019, *Pengaruh Variabel Makroekonomi Cina dan Amerika Serikat terhadap Nilai Tukar Rupiah (Studi pada International Monetary Fund dan Federal Reserve Bank 2009-2018)*, Cacik Rut Damayanti, S.Sos., M.Prof.Acc., D.BA, 110 Halaman + xiii.

Dunia ini dikelilingi oleh lebih dari 190 negara dan masing-masing memiliki kekuatan dan kelemahan mereka sendiri di berbagai bidang. Salah satu bentuk sosialisasi antara negara itu sendiri adalah melakukan perdagangan internasional dan proses perdagangan tentu saja menggunakan pembayaran. Setiap pembayaran biasanya membutuhkan uang. Penggunaan uang dalam transaksi internasional ditentukan dengan menggunakan mata uang yang disepakati, sering disebut nilai tukar. Untuk pertama kalinya dalam 3 tahun terakhir, nilai tukar rupiah mencapai level tertinggi. Pada saat bersamaan, terjadi perang dagang antara Cina dan Amerika Serikat. Tujuan dari penelitian ini adalah untuk menguji pengaruh variabel makroekonomi Cina dan Amerika Serikat, yaitu ekspor neto, pertumbuhan ekonomi dan inflasi terhadap nilai tukar rupiah Indonesia dengan menggunakan analisis regresi linier berganda. Penelitian ini menggunakan data perkuartal periode 2009 kuartal I hingga 2018 kuartal II dengan jumlah sampel 76 data time series untuk setiap variabel bebas.

Hasil dari penelitian ini menunjukkan bahwa; 1) Ekspor bersih Cina dan Amerika Serikat secara parsial memiliki pengaruh signifikan terhadap nilai tukar rupiah; 2) Pertumbuhan ekonomi Cina dan Amerika Serikat secara parsial memiliki pengaruh signifikan terhadap nilai tukar rupiah; 3) Inflasi Cina dan Amerika Serikat secara parsial memiliki pengaruh yang signifikan terhadap nilai tukar rupiah; 4) Ekspor bersih, pertumbuhan ekonomi dan inflasi Cina dan Amerika Serikat secara simultan mempengaruhi nilai tukar rupiah. Temuan dalam penelitian ini diharapkan dapat memprediksi fluktuasi nilai tukar Rupiah.

*Kata kunci: ekspor bersih, pertumbuhan ekonomi, inflasi, nilai tukar*

## FOREWORD

Thankfulness for the completion of this undergraduate thesis, researcher would like to present my deepest gratitude to the almighty Allah SWT for blessing and strength that have been given to me in finishing my undergraduate thesis entitled “The Influence of China’s and The United States’ Macroeconomic Variables on Rupiah Exchange Rate (Study at International Monetary Fund and Federal Reserve Bank 2009-2018)”. The undergraduate thesis is the final assignment submitted to Universitas Brawijaya in partial fulfillments for bachelor degree of Business Administration in Faculty of Administrative Science.

Researcher realized that the preparation of this thesis would not be completed well without the help and encouragement of various parties. Therefore, on this occasion, researcher would like to express gratitude to the honorable:

1. Mr. Prof. Dr. Bambang Supriyono, MS as Dean of the Faculty of Administrative Sciences, Universitas Brawijaya.
2. Mr. Dr. Mochammad Al Musadieg, MBA as Head of the Department of Business Administration, Faculty of Administrative Sciences, Universitas Brawijaya.
3. Ms. Nila Firdausi Nuzula, Ph.D as Head of the Business Administration Study Program, Faculty of Administrative Sciences, Universitas Brawijaya.



4. Ms. Cacik Rut Damayanti, S.Sos., M.Prof.Acc., D.BA as Supervisor, who provide the knowledge and guidance to the researcher so that this undergraduate thesis can be completed.
5. Beloved parents and siblings of researcher who offered countless prayers, moral and material support.
6. AIESEC in Universitas Brawijaya, especially for Executive Board 1819, OGV 1719 and MKT 1617 that already gave researcher a sincere support, so researcher gets motivated to finish this undergraduate thesis.
7. Dearest International Business 2015 & also all my friends in Business Administration who nevertheless had been supporting and accompanying for 4 years. Especially for Lingkaran Noob and VVIP who supported the most.
8. All parties who assist in the completion of this thesis that cannot be mentioned individually.

Researcher would like to say thank for all the support and assistance provided during the writing of the thesis. Researcher realizes that there are still many shortcomings and errors in the research. Researchers expect a criticism and suggestions to improve it even better.

Malang, 22 May 2019

Researcher

**TABLE OF CONTENT**

	Page
<b>MOTTO .....</b>	<b>i</b>
<b>APPROVAL SHEET .....</b>	<b>ii</b>
<b>BOARD OF EXAMINERS APPROVAL .....</b>	<b>iii</b>
<b>STATEMENT OF ORIGINALITY .....</b>	<b>iv</b>
<b>SUMMARY .....</b>	<b>v</b>
<b>RINGKASAN .....</b>	<b>vi</b>
<b>FOREWORD.....</b>	<b>vii</b>
<b>TABLE OF CONTENT .....</b>	<b>ix</b>
<b>LIST OF TABLES .....</b>	<b>xi</b>
<b>LIST OF FIGURES .....</b>	<b>xii</b>
<b>LIST OF APPENDIXES.....</b>	<b>xiii</b>
<b>CHAPTER I</b>	<b>INTRODUCTION</b>
	A. Research Background..... 1
	B. Research Problem..... 8
	C. Research Objective..... 9
	D. Research Contribution..... 10
	E. Systematics Discussion..... 11
<b>CHAPTER II</b>	<b>LITERATURE REVIEW</b>
	A. Empirical Review..... 13
	B. Theoretical Review..... 22
	1. Trade Approach Theory..... 22
	2. Purchasing Power Parity Theory..... 23
	C. Macroeconomics..... 24
	1. Net Exports..... 25
	2. Economic Growth..... 26
	3. Inflation..... 28
	4. Unemployment..... 30
	5. Interest Rate..... 31
	D. Exchange Rate..... 32
	1. Definition of Exchange Rates..... 32
	2. Exchange Rate System..... 33
	3. Factors That Influence Exchange Rates..... 36
	E. The Influences between Variables..... 38
	F. Conceptual Model..... 41
	G. Hypothesis Model..... 42
<b>CHAPTER III</b>	<b>RESEARCH METHOD</b>
	A. Type of Research..... 44
	B. Location of Research..... 45



C. Research Variables and Measurements.....	46
D. Research Population and Sample.....	48
E. Data Collection Technique.....	50
F. Data Analysis Technique.....	50
1. Descriptive Statistical Analysis.....	50
2. Classic Assumption Test.....	51
3. Inferential Statistical Analysis.....	54

**CHAPTER IV**

**RESULT AND DISCUSSION**

A. General Description of Country.....	58
1. Indonesia Overview.....	58
2. China Overview.....	58
3. United States Overview.....	59
B. General Description of Research Location.....	59
1. International Monetary Fund Overview.....	59
2. The Federal Reserve Bank Overview.....	61
C. Descriptive Statistical Analysis.....	63
1. Net Exports.....	64
2. Economic Growth.....	67
3. Inflation.....	72
4. Exchange Rate.....	75
D. Classic Assumption Test.....	76
1. Multicollinearity Test.....	76
2. Autocorrelation Test.....	77
3. Heteroscedasticity Test.....	78
4. Normality Test.....	79
E. Inferential Statistical Analysis.....	80
1. Multiple Linear Regressions Analysis.....	80
2. Simultaneous Test (F Test).....	82
3. Partial Test (t test).....	83
4. Coefficient Determination Analysis.....	85
F. Discussion.....	86

**CHAPTER V**

**CONCLUSION AND RECOMMENDATION**

A. Conclusion.....	91
B. Recommendation.....	93

<b>REFERENCES.....</b>	<b>95</b>
------------------------	-----------



**LIST OF TABLES**

<b>Number</b>	<b>Title</b>	<b>Page</b>
Table 1	Research Mapping .....	17
Table 2	Operational Definition of Variables.....	47
Table 3	Population and Sample.....	49
Table 4	Net Exports of China (in million USD) 2009:I-2018:II.....	64
Table 5	Net Exports of United States (in million USD) 2009:I-2018:II.....	65
Table 6	GDP of China (in million yuan) 2009:I-2018:II.....	68
Table 7	GDP of United States (in million USD) 2009:I-2018:II.....	70
Table 8	CPI of China 2009:I-2018:II.....	72
Table 9	CPI of United States 2009:I-2018:II.....	73
Table 10	Exchange Rate IDR-USD 2009:I-2018:II.....	75
Table 11	Result of Multicollinearity Test.....	77
Table 12	Result of Autocorrelation Test.....	78
Table 13	Result of Kolmogorov-Smirnov Test.....	80
Table 14	Result of Regression Coefficients of Exchange Rate .....	81
Table 15	ANOVA Result of Exchange Rate.....	82
Table 16	Model Summary of Exchange Rate.....	85

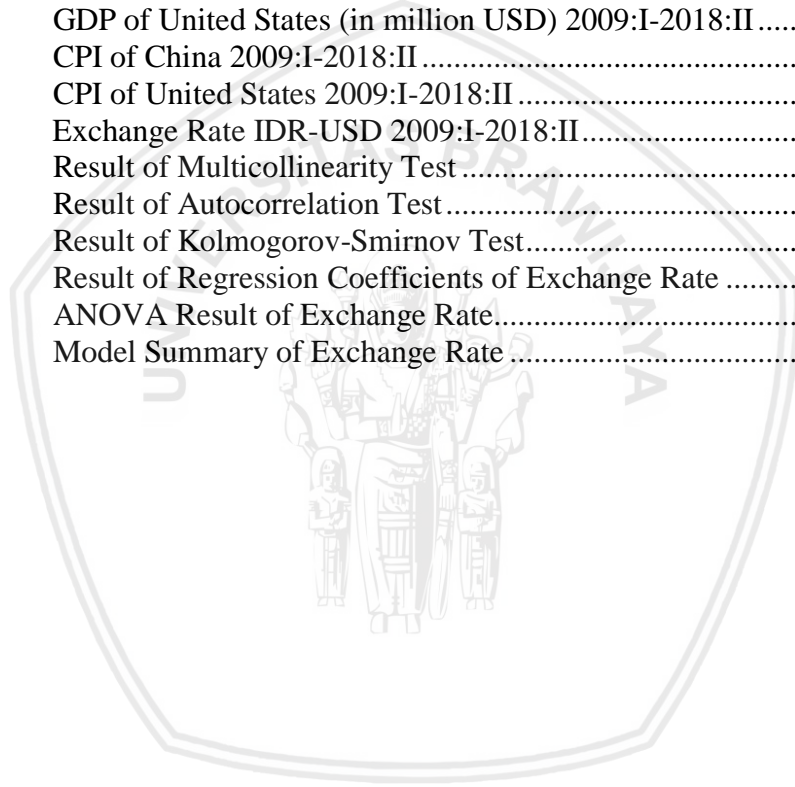

## LIST OF FIGURES

<b>Number</b>	<b>Title</b>	<b>Page</b>
Figure 1	Exports in Billion Dollar 2017 .....	5
Figure 2	Imports in Billion Dollar 2017 .....	5
Figure 3	Top 10 Countries with Highest GDP 2013 – 2017 .....	6
Figure 4	Exchange Rate Movements 2000-2017 .....	7
Figure 5	Conceptual Model .....	41
Figure 6	Hypothesis Model .....	42
Figure 7	International Monetary Fund Logo.....	59
Figure 8	The Fed Logo.....	61
Figure 9	Structure of the Federal Reserve System.....	62
Figure 10	Graphic of China’s net exports (in million USD).....	65
Figure 11	Graphic of United States’ net exports (in million USD) .....	67
Figure 12	Graphic of China’s GDP (in million yuan).....	69
Figure 13	Graphic of United States’ GDP (in million USD).....	71
Figure 14	Graphic of China’s CPI .....	73
Figure 15	Graphic of United States’ CPI .....	74
Figure 16	Graphic of IDR-USD Exchange Rate.....	76
Figure 17	Scatterplot Graphic .....	79

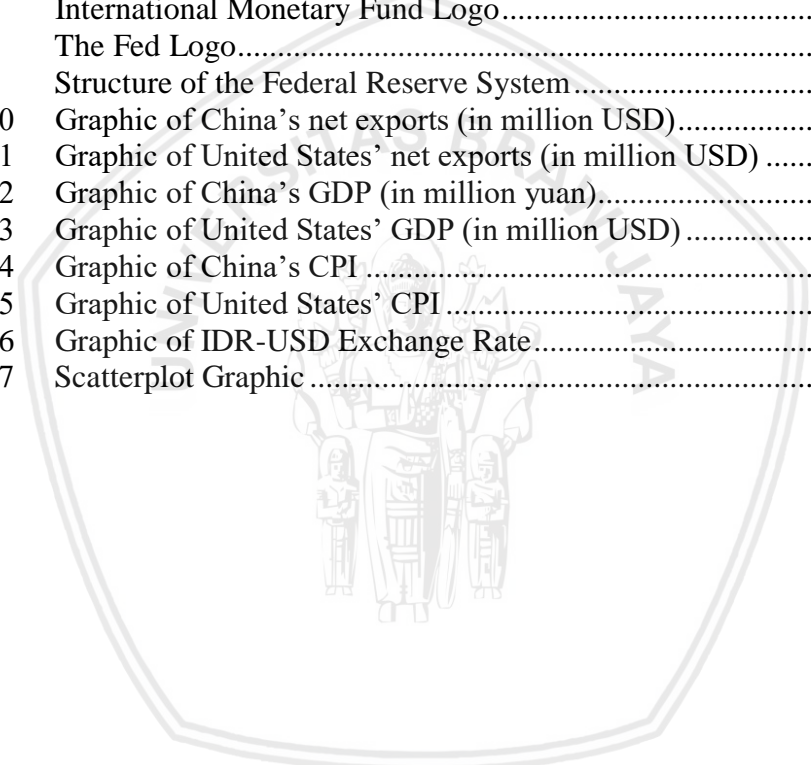

## LIST OF APPENDIXES

<b>Number</b>	<b>Title</b>	<b>Page</b>
Appendix 1	Net Exports Value of China .....	100
Appendix 2	Net Exports Value of United States .....	101
Appendix 3	GDP of China .....	102
Appendix 4	GDP of United States .....	103
Appendix 5	CPI of China .....	104
Appendix 6	CPI of United States .....	105
Appendix 7	Exchange Rate of IDR-USD .....	106
Appendix 8	SPSS 23.0 Result .....	107
Appendix 9	Scatterplot Graphic .....	109
Appendix 10	Kolmogorov-Smirnov Test .....	109
Appendix 11	Curriculum Vitae .....	110

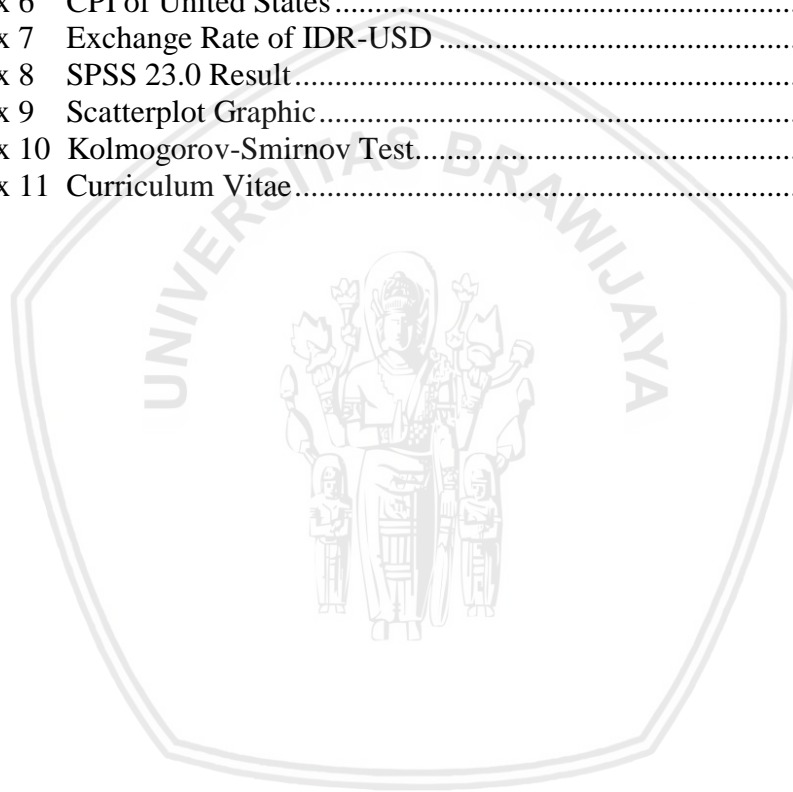

## CHAPTER I

### INTRODUCTION

#### A. Research Background

In 2018, Indonesia was shocked by the very high issue of exchange rates. For the first time in the past 3 years, Indonesian rupiah exchange rate reaches the lowest level. It was stated in Liputan6 (2018), the rupiah exchange rate has not been able to strengthen in trading on October, since the rupiah exchange rate is still in the position of Rp.15,100 per United States dollar.

It could happen because of a trade war that occurred between China and the United States. The tension of the trade war between the United States and China had a major impact on the economies of developing countries in the world, including Indonesia. According to Kompas (2018), the United States was an important trading partner for Indonesia. The number of Indonesian exports to the United States is ranked second from Indonesia's total exports. Likewise, China is one of the biggest trading partners with Indonesia. It was also stated in Kompas (2018) that Indonesia is highly affected by China especially in international trading, because China is one of Indonesia's biggest trading partner.

To know more about the issue that is currently happening above, it is important to know how international trade happens. As a human being it is

normal to socialize with others to exchange information and needs. It is also happening in this world, where each of the countries needs to have a social life. This world is surrounded by more than 190 countries and each of them has their own strengths and weaknesses in many different fields. One of the forms of socializing between the countries itself would be doing international trade.

There are no countries can live independent by themselves, which is why countries do trades to fulfill their needs. It was all explained more in the theory of comparative advantage. According to Madura (2000:8), “specialization in some products may result in no production of other products, so that trade between countries is essential”. It made it clearer that some countries are specialized in technologies, some are good at agricultures, some are better in human resources. These are the reasons why international trade happens, where one country has more and other countries have less.

The process of trading certainly uses payments, and in every payment usually requires money. In order to ensure that the international trade runs well, the use of money in the international transaction is determined using the agreed-upon currency. The agreed-upon currency often called exchange rate. According to Manurung, *et al.* (2008:91), what is meant by exchange rate is the currency of another country from an economic condition. Exchange rate in this case will be the payment instrument and represents how money works if it involves more than one country. “Most international business results in the exchange of one currency for another to make



payment” (Madura, 2000:17). Therefore, international trade has a risk that is clearly shown by the uncertainty of exchange rates.

The uncertainty or volatility of exchange rates is influenced by so many indicators. Volatility itself means value fluctuation that often describes the condition in trading field. According to Murni (2006:246), factors that influencing the volatility of exchange rate are interest changes, export, import, inflation, interest rate, investment return and also economic growth. Meanwhile Sukirno (2010: 402) reveals that changes in exchange rates are caused by changes in people's taste, changes in export and import prices, inflation, interest rates, and economic growth. It is proven that most of the factors came from macroeconomic sectors. By macroeconomics it means a study about economic phenomena in a huge scope, where it learns about inflation, unemployment and economic growth. (Mankiw, *et al.* 2014:4)

Based on the research conducted by Sedyaningrum (2016), there are some macroeconomic factors used as independent variables that can influence changes in the exchange rate. Sedyaningrum (2016) revealed that the independent variables which are exports, imports, and economic growth simultaneously have a significant influence on exchange rates of United States dollar and Indonesian rupiah. According to Handoko in Sedyaningrum (2016), it was explained that net exports influencing exchange rate significantly, which net exports means exports minus imports. Other than that, there are other macroeconomic variable that have influence towards exchange rate. In the research of Muzzaky (2015), it was stated that inflation has a significant and positive relation towards exchange rate.

Based on the previous research, macroeconomic indicators that can be used as variables are net exports, economic growth and inflation. The reason behind it is because net exports, economic growth and inflation are very correlated to prices of goods and services, which can be assumed that it will influence exchange rate. Each of the factors that were mentioned above might not influence the exchange rate directly, but through the supply-demand mechanism of the society towards a currency. Like what Madura (2000:89) explained, import in a country can indirectly revealed the society demand towards a currency are based on the import payments itself. It can be concluded that in some way there are macroeconomic factors that influencing exchange rate, which will also affect how international trade happens.

China and United States are known as leaders in the current condition of world's trading and economy. Both countries have a good trade relationship in many different fields of business, also actively do export and import. From the latest data of Central Intelligence Agency (2017), United States and China have been the top exporter & importer along with other top 5 countries. The top exporter in 2017 was China, United States, Germany, Japan and South Korea, meanwhile the top importer 2017 was United States, China, Germany, Japan and France. To make it clear, the description is stated in figure 1 and figure 2:

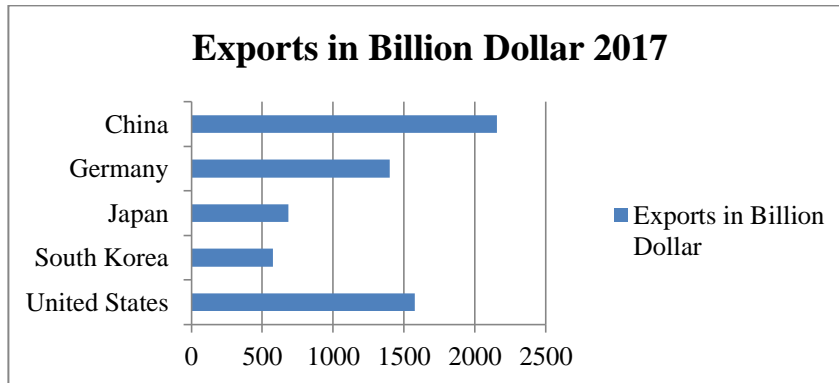

**Figure 1. Exports in Billion Dollar 2017**

Source: Central Intelligence Agency (Data processed, 2018)

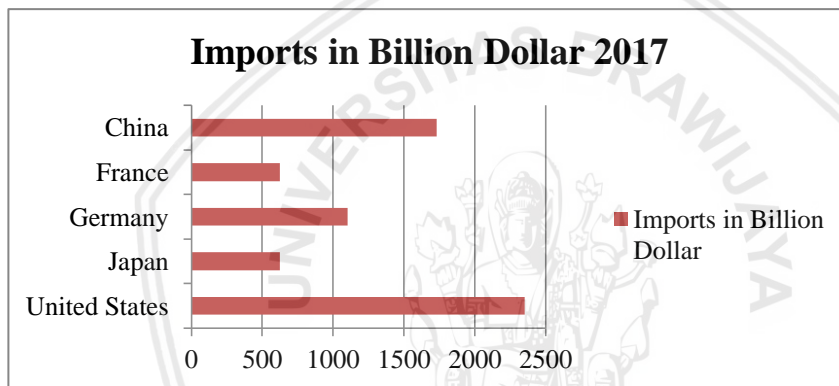

**Figure 2. Imports in Billion Dollar 2017**

Source: Central Intelligence Agency (Data processed, 2018)

Other than exports and imports, China and United States are also leading in economic growth. The economic growth can be measured with GDP. It will be shown in figure 3 that both countries have the biggest amount of GDP among all countries. According to Consensus Forecast in Focus Economics (2018), the top 10 countries that forecasted will lead GDP in 2019 & 2020 are United States, China, Japan, Germany, UK, India, France, Italy, Brazil, and Canada. The figure below shows the amount of GDP from International Monetary Fund website, which represents the forecast that was created by researcher from Consensus Forecast:

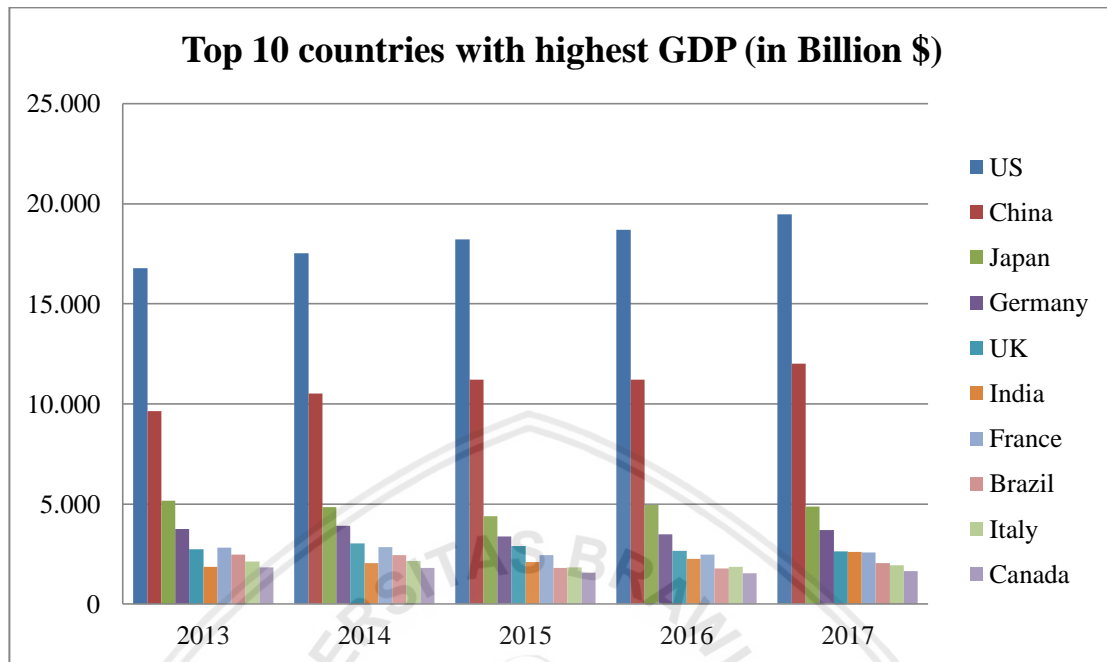

**Figure 3. Top 10 Countries with Highest GDP 2013 – 2017**

Source: International Monetary Fund (Data processed, 2018)

The growing of China and United States economic made a huge difference especially when Donald Trump was elected as the new president of the United States. It was stated in New York Times (2018), Trump imposes tariffs on allies and rivals including China. It was triggering a series of tit for tat tariffs and threatened additional tariffs from multiple nations. In United States – China case, it was first happening when United States imposes steel and aluminum imports tariff to China. China then replied with wine, pork and pipes tariffs. The retaliation keeps on going until both demonstrated a willingness to offer concessions to get what they want. Both countries somehow created a trade war to sustain their position in world's economy.

The current trade war that is happening have an impact to prices in both China and United States. If more tariffs are imposed in both countries, there might be prices increasing in several goods and services due to respond of the trade war. According to Sukirno (2010:14), the prices prevail in an economy increases can be defined as inflation. Inflation might happen to both China and United States during the current situation.

Despite the trade war that is currently happening, China and United States seems to always grow and shows that trading activities can affect the macroeconomic indicator of the country. As stated in the previous paragraph, macroeconomic indicator can be the factors of exchange rate volatility. Since the year of 2000 until 2017, the exchange rate between Indonesian rupiah and United States dollar is continuously fluctuating. From year 2000 until 2013, the rate was fluctuating around Rp.8,421 until Rp.10,461. Meanwhile in 2014 until 2017 the rate was fluctuating around Rp.13,000, it is shown in the figure below:

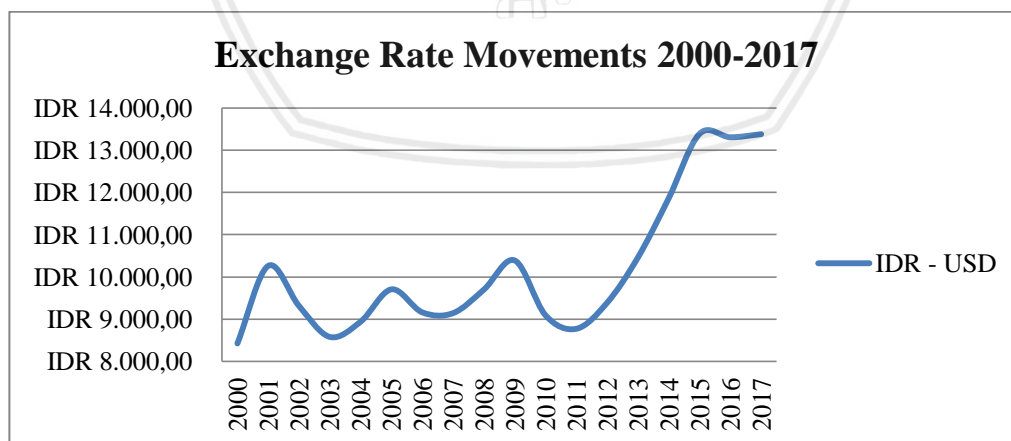

**Figure 4. Exchange Rate Movements 2000 – 2017**

Source: OECD National Accounts Statistics (Data processed, 2018)

The trade war sure did an impact to the trading environment, and it can cause changes in the world since China and United States are the leaders in international trading. The increases of tariffs that both China and United States applied to each other can create an appreciation or depreciation in the prices of international transaction. According to Mankiw (2012:386), prices serve the important role to coordinate the decisions of consumers and produces as they interact in world market, the price itself are referred as exchange rate. In this case, the volatility of exchange rate itself can be affected by it.

Researcher wants to identify the influence of China's and the United States' macroeconomic variables on rupiah exchange rate, because researcher wants to know whether or not China's and United States' macroeconomic variables have an influence to Indonesian rupiah exchange rate. By this research, government or company can also forecast what should be done to face this kind of phenomena, especially those who actively involved in international trading. Based on what is described above, researcher is interested in doing a research with a title **“The Influence of China's and the United States' Macroeconomic Variables on Rupiah Exchange Rate (Study at International Monetary Fund and Federal Reserve Bank 2009-2018).”**

## **B. Research Problem (s)**

Based on the background that is stated above, the problem formulations of this research are as follows:

1. Is there any significant influence between China's and United States' net exports towards Indonesian rupiah exchange rate?
2. Is there any significant influence between China's and United States' economic growth towards Indonesian rupiah exchange rate?
3. Is there any significant influence between China's and United States' inflation towards Indonesian rupiah exchange rate?
4. Is there any simultaneous influence between China's and United States' net exports, economic growth, and inflation towards Indonesian rupiah exchange rate?

### **C. Research Objective (s)**

Based on research problems that are formulated above, the objectives of this research are as follows:

1. To analyze the significant influence of China's and United States' net exports towards Indonesian rupiah exchange rate.
2. To analyze the significant influence of China's and United States' economic growth towards Indonesian rupiah exchange rate.
3. To analyze the significant influence of China's and United States' inflation towards Indonesian rupiah exchange rate.
4. To analyze the simultaneous influence of China's and United States' net exports, economic growth, and inflation towards Indonesian rupiah exchange rate.

#### **D. Research Contribution (s)**

This research gives the contributions both in academical and practical. The contributions are described below:

##### **1. Academic Contribution**

- a. The result of this research is expected to become a reference and also material contribution for the same field (especially for the research that conducts in macroeconomics field). This research also can be developed in the future related with an event that effect on exchange rate volatility. This research's result is also expected to be used for further research, because there are still a few researches that look at the influence of foreign macroeconomic variables on certain countries. Most of the previous researches only look at the internal macroeconomic data of the country.
- b. The result of this research is expected to provide additional information for further research that addresses issues in the same field. The issue itself will be about macroeconomic variables that influence exchange rate.

##### **2. Practical Contribution**

- a. This research is expected to be used as information for companies especially multinational ones, also the wider community to understand and able to solve problems related to the volatility of exchange rate. The research could give an aiming for companies on how to react if the volatility of exchange rate happens.



- b. This research can be the input for the government as an additional reference to consider national policies and decision making in economic matters. It could be in how to maintain the nation's exchange rate or maintain prices regarding international trading, especially regarding the exports and imports activities.

### **E. Systematics Discussion**

Systematics discussion needed to expand the understanding about the content of the research. The compositions of the research are:

#### **CHAPTER I INTRODUCTION**

This chapter explains the background of the research, research problem, research objectives, research contribution, and also the systematic discussion.

#### **CHAPTER II LITERATURE REVIEW**

In this chapter, it consists of previous research and theoretical basis that support the research. The theory focuses on macroeconomics variables that are used in the research that can affect exchange rate. The theory will be formulated into concept and hypothesis.

#### **CHAPTER III RESEARCH METHOD**

This chapter explains about type of research that will be used. It will also consist of concept, definition of operational

variables, measurement scale, population, sample, data source and data collection methods. Data analysis method will also include in this chapter.

#### **CHAPTER IV RESEARCH RESULT**

Chapter IV consists of analysis and the result of the research. It will discuss the results of the methodology that was described in Chapter III. In this chapter, the hypothesis that was made will be proved.

#### **CHAPTER V CONCLUSION**

This chapter contains of conclusion based on the research result and alternative suggestions which are expected to be a benefit of the research.

## CHAPTER II

### LITERATURE REVIEW

#### A. Empirical Review

##### 1. Dion, *et al.* (2005)

The research conducted by Dion, *et al.* was titled "Exports, Imports and the Appreciation of Canadian Dollar". This study used exports and imports as an independent variable that affected the appreciation of the Canadian dollar as a dependent variable. Regression was used to conduct the research and the sample of the research was quarter data from 2001-2005. This result showed that exports and imports of Canada had a significant influence on the appreciation of the Canadian dollar 2003, 2004 to mid 2005.

##### 2. Astiyah, *et al.* (2005)

The title of the research is "*Nilai Tukar dan Trade Flows*". This study used foreign exchange rate as independent variables that affected the trade flows of Indonesia. The trade flows was the dependent variables which consist of exports and imports value. The analysis method in this research was using panel regression with monthly data from January 2002 until March 2005 as the sample. The result showed that exchange rate significantly influenced exports and imports.

### 3. Suselo, *et al.* (2008)

The research title is “*Pengaruh Volatilitas Nilai Tukar terhadap Pertumbuhan Ekonomi Indonesia*”. In this research, the independent variable was rupiah exchange rate, meanwhile the dependent variable was the economic growth of Indonesia. Suselo, *et al* used ARCH/GARCH, Generalized Method of Moments and Vector Auto Regressive method. The sample of the research were quarter data from 1990-2005. The result showed that exchange rate volatility had negative impact on economic growth.

### 4. Rusdiana (2011)

The title of the research is “*Analisis Pengaruh Inflasi, Suku Bunga Bank Indonesia, Produk Domestik Bruto, Net Ekspor dan Cadangan Devisa Terhadap Nilai Tukar*”. In this research, the exchange rate that is used was between Indonesian rupiah and euro. The analysis method that was used are multiple linear regression. The research result showed that inflation, interest rate, GDP, export net, and foreign exchange reserves simultaneously influenced the exchange rate. Inflation and interest rates also partially influenced exchange rates. Yet the GDP, export net, foreign exchange reserves partially influenced the exchange rate insignificantly.

### 5. Widiastuti (2011)

The title of the research is “*Analisis Pengaruh Jumlah Uang Beredar, Suku Bunga Indonesia dan Inflasi (IHK) Terhadap Nilai Tukar Rupiah tahun 2000-2009*”. Multiple linear regression was used as the method of the analysis. The

sample of the research were quarter data from 2000-2009. Based on simultaneous test, this research showed that the independent variables together had a significant influence on the exchange rate. Based on the partial test result, the independent variables which are amount of money supply, interest rate, and inflation also had significant influence on the exchange rate.

#### **6. Puspitaningrum (2013)**

The title of the research is “*Pengaruh Tingkat Inflasi, Tingkat Suku Bunga SBI, dan Pertumbuhan Ekonomi Terhadap Nilai Tukar Rupiah*”. This research was using multiple linear regression, with 40 samples from 2003-2012 quarter data. The result of this research was inflation rate, SBI interest rate, and economic growth had a simultaneous effect on the rupiah exchange rate. However, based on the hypothesis testing of the t test (partial), it can be seen that the variable inflation rate and SBI interest rate had a significant effect on the rupiah exchange rate. While economic growth partially had no significant effect on the rupiah exchange rate.

#### **7. Muzakky (2015)**

The title of the research is “*Pengaruh Inflasi, Tingkat Suku Bunga SBI, Pendapatan Per Kapita, dan Ekspor terhadap Nilai Tukar Rupiah dan Pertumbuhan Ekonomi*”. This research was using multiple linear regression, with 48 samples from 2002-2013 quarter data. Based on simultaneous test, the independent variables which are inflation, interest rate, income per capita, and export had a significant effect on exchange rates and economic growth.

Meanwhile based on the partial test, inflation, export and income per capita had a significant effect towards exchange rate.

#### **8. Sedyaningrum (2016)**

The title of the research is “*Pengaruh Jumlah Nilai Ekspor, Impor dan Pertumbuhan Ekonomi Terhadap Nilai Tukar dan Daya Beli Masyarakat di Indonesia*”. This research was using multiple linear regressions, with 36 samples from 2006-2015 quarter data. In this research, simultaneous test results showed that exports, imports, and economic growth had a significant influence on exchange rates and purchasing power. Meanwhile, partial test results indicate that the export variables had a significant influence on the exchange rate, while exports and imports variable had a significant influence on the purchasing power.

#### **9. Venkatesan, et al. (2017)**

The research that was conducted by Venkatesan, *et al.* titled “An Analysis of Macroeconomic Factors Affecting Foreign Exchange Rate”. In this research it was mentioned that there are many factors that influenced the exchange rate such as inflation, GDP, money supply, oil price, bank rate, current account deficit, FII, FDI, WPI, exports, imports, etc. But in this study, the specific variable that was picked are FDI, inflation, CAD, interest rate, oil price and GDS as the independent variables. Venkatesan, *et al* used ADF test, Vector Auto Regressive and ARDL method with 15 years of sample from 2000-2015. The result of the research was the independent variables had impact on each other which affects overall to the economy as well as exchange rate.

**Table 1. Research Mapping**

No.	Author, Year and Title of Research	Research Variables	Result	Research Equation	Research Difference
1.	Dion, <i>et al.</i> (2005) "Exports, Imports and the Appreciation of Canadian Dollar "	X <sub>1</sub> = Exports X <sub>2</sub> = Imports Y <sub>1</sub> = Canadian dollar exchange rate	This research shows that exports and imports Canada has a significant influence on the appreciation of the Canadian dollar 2003-2005.	Using the same dependent variables which are exchange rate of Canadian dollar.	Not using the same independent variables which are Inflation and GDP. Also in this research exports and imports are counted not as net exports.
2.	Astiyah, <i>et al.</i> (2005) "Nilai Tukar dan Trade Flows"	X <sub>1</sub> = Exchange Rate Y <sub>1</sub> = Exports Y <sub>2</sub> = Imports	This research shows that exchange rate significantly influence exports and imports.	Using the same variable which is exchange rate and exports imports.	The exchange rate in this research is independent variable, not dependent variables. This research did not count the exports imports as net exports, meanwhile as a separated variable.

Continued Table 1. Research Mapping

No.	Author, Year and Title of Research	Research Variables	Result	Research Equation	Research Difference
3.	Suselo, <i>et al.</i> (2008) “ <i>Pengaruh Volatilitas Nilai Tukar terhadap Pertumbuhan Ekonomi Indonesia</i> ”	X = Exchange Rate Y = Economic Growth	The model applied in the research uses exchange rate volatility channeled through the investment and trade. The research shows a negative influence of both real and nominal exchange rate towards economic growth.	Using the same variable which is exchange rate and economic growth.	The exchange rate in this research is independent variable, not dependent variables. This research is not using the exact same macroeconomic variables for the independent variables.
4.	Rusdiana (2011) “ <i>Analisis Pengaruh Inflasi, Suku Bunga Bank Indonesia, Produk Domestik Bruto, Net Ekspor dan Cadangan Devisa Terhadap Nilai Tukar</i> ”	X <sub>1</sub> = Inflation X <sub>2</sub> = Interest Rate X <sub>3</sub> = GDP X <sub>4</sub> = Foreign Exchange Reserves Y <sub>1</sub> = Exchange Rate	F test shows that independent variable simultaneously influence the dependent variable. T test shows that only inflation and interest rate partially influence the exchange rate.	Using the same independent variables which are inflation, GDP and also exports net, and also using exchange rate as the dependent variable.	Not using foreign exchange reserves and also interest rate as the independent variables.



Continued Table 1. Research Mapping

No.	Author, Year and Title of Research	Research Variables	Result	Research Equation	Research Difference
5.	Widiastuti (2011) “ <i>Analisis Pengaruh Jumlah Uang Beredar, Suku Bunga Indonesia dan Inflasi (IHK) Terhadap Nilai Tukar Rupiah tahun 2000-2009</i> ”	X <sub>1</sub> = Money Supply X <sub>2</sub> = Interest Rate X <sub>3</sub> = Inflation Y <sub>1</sub> = Exchange Rate	F test shows that independent variables together have a significant influence on the exchange rate. T test shows money supply, interest rate, and inflation also has significant influence on the exchange rate.	Using the same independent variable which is inflation. Also using the same dependent variable which is exchange rate.	Not using money supply and interest rate as the independent variables. Widiastuti’s research did not use exports net and economic growth as the independent variables.
6.	Puspitaningrum (2013) “ <i>Pengaruh Tingkat Inflasi, Tingkat Suku Bunga SBI, dan Pertumbuhan Ekonomi Terhadap Nilai Tukar Rupiah</i> ”	X <sub>1</sub> = Inflation X <sub>2</sub> = Interest Rate X <sub>3</sub> = Economic Growth Y <sub>1</sub> = Exchange Rate	F test shows that independent variables simultaneously influence the dependent variable. T test shows that only inflation and interest rate have a significant influence on the exchange rate.	Using the same independent variables which are inflation and economic growth. Meanwhile also using the same dependent variable which is exchange rate.	Not using interest rate as the independent variable. And Puspitaningrum’s research did not use exports net.

Continued Table 1. Research Mapping

No.	Author, Year and Title of Research	Research Variables	Result	Research Equation	Research Difference
7.	Muzzaky (2015) “Pengaruh Inflasi, Tingkat Suku Bunga SBI, Pendapatan Per Kapita, dan Ekspor terhadap Nilai Tukar Rupiah dan Pertumbuhan Ekonomi”	X <sub>1</sub> = Inflation X <sub>2</sub> = Interest Rate X <sub>3</sub> = Income per capita X <sub>4</sub> = Export Y <sub>1</sub> = Exchange Rate	F test shows that independent variables have a significant influence on dependent variables. T test shows that inflation, export and income per capita have a significant influence towards exchange rate.	Using inflation and export as the independent variables. And exchange rate as the dependent variables.	Not using interest rate, income per capita as the independent variables. Also the economic growth is on dependent variables, not independent variables.
8.	Sedyaningrum (2016) “Pengaruh Jumlah Nilai Ekspor, Impor dan Pertumbuhan Ekonomi Terhadap Nilai Tukar dan Daya Beli Masyarakat di Indonesia”	X <sub>1</sub> = Export X <sub>2</sub> = Import X <sub>3</sub> = Economic Growth Y <sub>1</sub> = Exchange Rate Y <sub>2</sub> = Purchasing power	F test shows that exports, imports, and economic growth have a significant influence on exchange rates and purchasing power. T test shows export variable has a significant influence on the exchange rate, while exports and imports variable had a significant influence on the purchasing power.	Using economic growth as the independent variables. Also using exchange rate as the dependent variables.	Instead of using exports and imports, the research is using net exports. Sedyaningrum’s research is using purchasing power as the dependent variables.

**Continued Table 1. Research Mapping**

No.	Author, Year and Title of Research	Research Variables	Result	Research Equation	Research Difference
9.	Venkatesan, <i>et al.</i> (2017) “An Analysis of Macroeconomic Factors Affecting Foreign Exchange Rate”	X <sub>1</sub> = FDI X <sub>2</sub> = Inflation X <sub>3</sub> = CAD X <sub>4</sub> = Interest Rate X <sub>5</sub> = Oil Price X <sub>6</sub> = GDS Y <sub>1</sub> = Exchange Rate	The independent variables had influence on each other which affects overall to the economy as well as exchange rate.	Using the same macroeconomic factor which is inflation. Also using exchange rate as the dependent variables.	Not using FDI, CAD, interest rate, oil price and GDS as the independent variables.

Source: Data processed by researcher, 2018

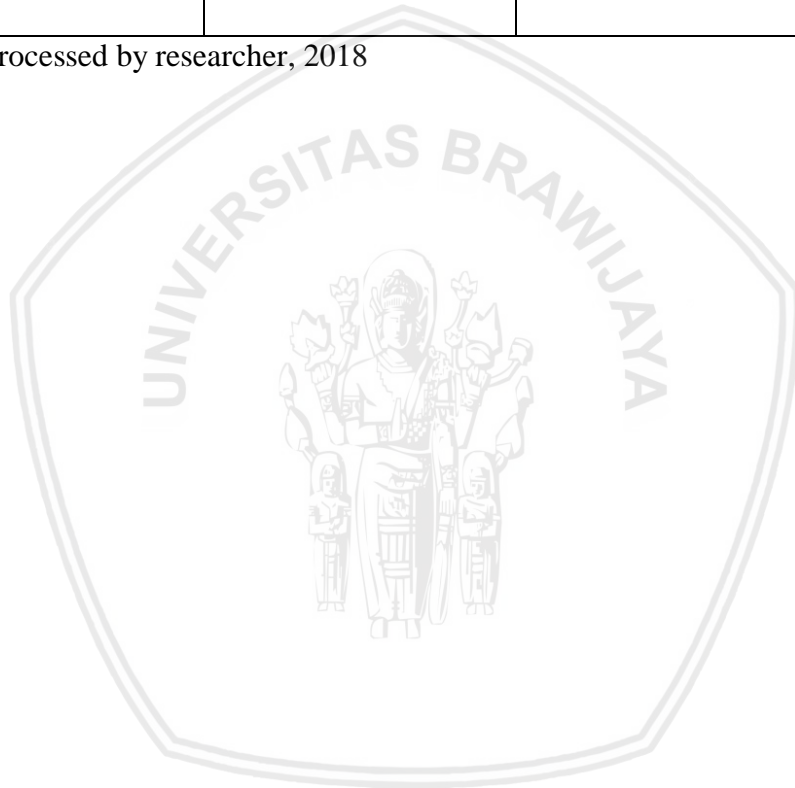

## **B. Theoretical Review**

### **1. Trade Approach Theory**

Exchange rates are calculated through the exchange of goods and services between countries, or commonly referred to as trade. According to Ekananda (2014:225) this is based on the theory of trade approach or commonly also called as elasticity approach to exchange rate determination, who claims that exchange rate determined by the size of the trade in goods and services that take place between the countries concerned. Based on the approach, the equilibrium rate is the rate that balances the value of exports and imports, which can be denoted as NX.

In this theory, if the country's import value is greater than its export value (trade deficit), the exchange rate will increase or experience depreciation. Vice versa, if the export value exceeds the import value (trade surplus), the country's currency will decrease or experience appreciation (Ekananda, 2014:225). The theory is also mentioned in Salvatore, as follows:

“One traditional and crucial exchange rate model is based on flows of goods and services and is, therefore, to as the trade or elasticities approach. According to this approach, the equilibrium exchange rate is the one that balances the value of the nation's imports and exports. If the value of the nation's imports exceeds the value of the nation's exports (i.e., if the nation faces a trade deficit), then the exchange rate will rise (i.e., the domestic currency will depreciate) under a flexible exchange rate system. This makes the nation's exports cheaper to foreigners and imports more expensive to domestic residents. The result is that the nation's exports rise and its imports fall until trade is balanced” (Salvatore, 2009:405)

## 2. Purchasing Power Parity Theory

Exchange rate determination could be affected by many reasons. One of the most popular and controversial theory about exchange rate determination is Purchasing Power Parity or known as PPP. This theory was first developed by economist named Sweden Gustav Cassel to estimate the balance of exchange rates after the onset of World War I (Salvatore, 2014:70). The theory based on the opinion of Madura (2000:214), is a picture of the exchange rate balance adjusted for the amount of difference in the level of prices between two countries, and based on PPP it can be known the level of demand and supply of foreign currencies. This theory is divided into two forms, which is absolute form of PPP and relative form of PPP.

According to Madura, *et al* (2007:281) “the absolute form of PPP is based on the notion that without international trade barriers and transport costs, consumers shift their demand to wherever the prices are lower”. This theory is also known as the law of one price. The absolute PPP theory said that the equilibrium exchange rate is equal to the ratio of the price level in the two nations (Salvatore, 2009:473). The example of absolute form of PPP will be mention as follows:

“If the same basket of product is produced by the United States and the United Kingdom, and the price in the United Kingdom is lower when measured in a common currency, US consumers should seek to import the cheaper UK products. Consequently, the actual price charged from each country may be affected, and/or the exchange rate may adjust. Remember that for a US resident seeking to import the cheaper goods from the UK, an increase in the

value of the British pound represents a price rise just as much as an increase in the price of the goods themselves.” (Madura, *et al*, 2007:281)

Meanwhile according to Madura, *et al* (2007:281) “the relative form of PPP accounts for the possibility of market imperfections such as transportation costs, tariffs, and quotas”. Based on this theory, the prices of goods or services should be similar when measured in a common currency, with barriers of trade and transportation cost. Salvatore (2009:474) also said that “relative purchasing power parity postulates that the change in the exchange rate over period of time should be proportional to the relative change in the price levels in the two nations over the same time period”. The example of relative form of PPP will be mention as follows:

“If the general price level does not change in the nation B from the base period to period 1, while the general price level in nation A increases by 50 percent, the relative PPP theory postulate that the exchange rate between the currency nation A and the currency of nation B (define as the price of the latter in terms of the former) should be 50 percent higher. (i.e., nation A’s currency should depreciate by 50 percent) in period 1 as compared with the base period” (Salvatore, 2009:474)

### **C. Macroeconomics**

The field of economy is divided into 2 components, where one component is macroeconomics and the other is microeconomics. “Macroeconomics is the study of economy wide phenomena, including inflation, unemployment and economic growth” (Mankiw, 2012:29). Macroeconomics can make an understanding on how economy works and helps us interpret what is happening in the past. It can also help

to think what could possibly happen in the future that is related to the world economy. According to Miles, *et al.* (2012:7), macroeconomics studies the economy as a whole where it is the aggregate outcomes of consumers, firms and the government itself.

Since macroeconomics is studying economy as a whole, macroeconomics itself has so many variables. Relationships learned in macroeconomics are causal relationships between aggregative variables, and among them the variables in question are national income, inflation, interest rates, balance of payments (exports and imports), investments, unemployment and others (Putong, 2013: 273). The following is the explanation of some variables that is learned in macroeconomics:

### **1. Net Exports**

Before getting to know net exports further, it's good to understand what imports and exports are. According to Mankiw (2010:272), imports are goods and services that produced abroad and sold domestically, meanwhile exports are goods and services that produced domestically but sold abroad. Imports and exports are often called as international trading. Therefore net exports can also be called trade balance.

Net exports are defined when the export value is reduced by the import value of a country. When net exports are positive, it means the country did more exports than imports. Economists called it trade surplus. If the net exports are negative, it means the country did more imports than the exports. Economists called it trade

deficit. When the exports and imports are in an equal value, it is often called balanced trade.

The condition where trade deficit, trade surplus and balanced trade happened is affected by some factors. These factors might influence the value of imports, exports and net exports. According to Mankiw (2010:273), those factors include the following:

- a. The taste of consumers for domestic and foreign goods
  - b. The prices of goods at home and abroad
  - c. The exchange rates at which people can use domestic currency to buy foreign currencies
  - d. The income of consumers at home and abroad
  - e. The cost of transporting goods from country to country
  - f. Government policies towards international trade
- (Mankiw, 2010:273)

## **2. Economic Growth**

Economic growth often used to see economic condition in a long-term period. Based on Putong (2013:411), what is meant by economic growth is an increase in national income in a certain period. According to Sukirno (2010:56), economics can be considered growing if the remuneration of real services for the factors of production in a given year is greater than in previous years. In rough picture, economic growth of a country can be measured using the gross domestic product (GDP) rate that is achieved by that country. GDP is an income earned by a country either permanent residents or immigrants and the formula that usually used to determine the GDP rate of a country is stated as follows:



$$g = \frac{GDP_1 - GDP_0}{GDP_0} \times 100\%$$

Source: Sukirno (2010:420)

Explanation:

g = GDP

GDP<sub>1</sub> = GDP<sub>0</sub> in the period of certain year

GDP<sub>0</sub> = GDP in the previous year period

Theoretically, economic growth is used to measure and to explain the factors that determine economic condition of a country. There are two neo-classic theory of economic growth that was stated by past economists. Those two theories are the theory of Harrod –Domar and the theory of Solow-Swan.

According to Boediono (2010:79) there are 3 things that Harrod-Domar assumes in the theory. First, the theory said that economy in full employment, and capital goods in the community are fully utilized. Second Harrod-Domar also assumes that the amount of public savings is proportional to income national. Third, economy consists of the household sector and the corporate sector.

Other than Harrod-Domar, there is another theory called Solow-Swan. This theory was developed by Solow and Swan. Solow-Swan assumes that economic growth depends on increasing availability of production factors and level of technological progress in a country. Same as the case with Harrod-Domar's theory, Solow-Swan theory also focuses attention on population growth, capital

accumulation, technological progress and output that interact with each other in the process of economic growth (Boediono, 2006:81). This theory assumes that not only the development of capital and labor that affects economic growth, but technological progress also has an important influence on the output produced in the production process.

### **3. Inflation**

One of the macroeconomic problems that always occurred as the government concern is inflation. The government is responsible to keep the inflation rate at a low level. Based on Sukirno (2010:14), inflation can be defined as a process where the prices prevail in an economy increases. The percentage of inflation rate will be different year to year, also one country to another. According to the increase rate, inflation is divided into something called creeping inflation and hyperinflation.

Creeping inflation shows a slow increase where the inflation rate does not exceed 2-3 percent a year, while hyperinflation shows a fast increase where the rate exceeds 10 percent a year. However, there are some countries that do not experience hyperinflation but are unable to reduce their inflation rate to low. It is often called moderate inflation, where the rate reaches 5-10 percent a year (Sukirno, 2010:337). Meanwhile according to the causing factors, Nanga (2005:245) revealed that there are three categories of inflation. The three causing factors of inflation are stated as follows:

a. Demand-pull inflation

Could be called Demand-Side inflation/Demand-Shock inflation is inflation that occurs because of an increase in aggregate demand that are too large compared with the aggregates supply or production. Goods to be reduced because the utilization of the resources that have maximum level reached or because of production can't be increased to offset the demand growing.

b. Cost-push inflation

Often called Supply-Side inflation/Supply-Shock inflation is inflation that occur because the rapid increase in production cost compared with productivity and efficiency, or in other words as a result of a restriction or limitation on supply of one or more resources, or the price of a resources increase.

c. Structural inflation

The inflation occurs as a result of existence of various obstacles or structural rigidities that cause supply in economy become less or not responsive to increased demand.

Inflation rate can be measured by CPI or consumer price index. CPI is a measurement of overall cost of goods and services that is purchased by consumers (Mankiw, *et al.* 2014:24). The CPI changes the prices of goods and services into an index. Later, the index can measure the overall price level and will show how much is the inflation rate of a country. In example, the inflation rate can be measure by CPI between two consecutive years that is computed as follows:

$$\text{Inflation Rate in year 2} = \frac{\text{CPI in year 2} - \text{CPI in year 1}}{\text{CPI in year 1}} \times 100\%$$

Source: Mankiw (2012:220)

#### 4. Unemployment

Unemployment or unemployed people are those who do not have jobs (Putong, 2013:426). This category is given to people who do not have a job during working age. Based on the type, there are three types of unemployment. The three type according to Putong are cyclical unemployment, frictional unemployment and structural unemployment, which will be explained as follows:

##### a. Cyclical unemployment

This unemployment is unemployment which occurs when demand is lower than the potential output of the economy. The economic capability of a country is lower than the ability that should be achieved. This type is categorized as forced unemployment, because many workers wants to work with the prevailing wage level but the field is not available.

##### b. Frictional unemployment

This unemployment is unemployment that occurs when there is a rotation in the scope of work and employment. Unemployment exists because a new workforce is ready to enter employment, while those who have worked, quit their jobs to find new jobs.

c. Structural unemployment

This unemployment is unemployment that occurs when there is a discrepancy between the structure of the workforce based on education, gender, occupation, geography, information, industry and demand. The causes of unemployment are natural, because of the trend of specific labor needs.

## 5. Interest Rate

According to Sunariyah (2006:80), interest rate is the price of a loan, expressed as a presentation of principal per unit. Interest is a measure of the price of resources used by debtors paid to creditors. Interest rates have an important role in making investment decisions. A lower interest rate than the rate of return of capital causes the planned investment to be unprofitable and makes the investment plan canceled.

According to Sukirno (2010:125-127), investment activities will only be carried out if the return on capital is greater or equal to the interest rate. There are several factors that influence the interest rate. According to Brigham and Houston (2011: 191), the factors that influence interest rate are central bank policy, surplus or deficit of the state budget, international factors and the level of business activity.

Based on the explanation of macroeconomic above, researcher choose net exports, economic growth and inflation as the dependent variable of the research. Net exports, economic growth and inflation may reflect the current condition of how

international trading is taking place and describe prices of goods and services. Which will also correlate with the determination of exchange rate, since exchange rate are the methods used as trading payments.

Meanwhile researcher does not take unemployment and interest rate as the variable of the research. Based on Harrod-Domar in Boediono (2010:79), economic growth can be measured when the economy is in full employment and capital goods are fully utilized. From the statement, the unemployment rate and interest rate can be included in a country's economic growth. Therefore, the variables used are only those that are directly related to trading and prices.

#### **D. Exchange Rates**

##### **1. Definition of Exchange Rates**

According to Manurung, *et al.* (2008:91), what is meant by exchange rate is the currency of another country from an economic condition. Meanwhile, Madura (2000:86) said that “foreign exchange rate is to measure the value a currency from the perspective of other currencies”. For example, the exchange rate of rupiah against the United States dollar is the price of one dollar (USD) in rupiah (IDR), and vice versa.

Economists distinguish two exchange rates as international prices, which is nominal exchange rate and real exchange rate. People uses nominal exchange rate in daily life. According to Mankiw (2012:386), nominal exchange rates are “the rate at which a person can trade the currency of one country for the currency of

another". There are many nominal exchange rates for a country. For example, the United States dollar can be used to buy British pounds, Japanese yen, Mexican peso and so on. The economist often uses indexes that average exchange rates, to refer when a currency is appreciating or depreciating. If a currency's value decreasing, it is often indicates as depreciation, however the increase in a currency value is often indicates as appreciation.

While real exchange rate is "the rate at which a person can trade the goods and services of one country for the goods and services of another" (Mankiw, 2012:388). Real and nominal exchange rates are closely related, but in this instance the item is a good rather than a currency. For example, a sack of American rice sells for \$100 and a sack of Japanese rice sells for 16,000 yen. If the nominal exchange rate is 80 yen per dollar, then a price for American rice of \$100 per sack is equivalent with 8,000 yen per sack. American rice is half as expensive as Japanese rice. To summarize the case above, the calculation for the real exchange rate is according to the following formula:

$$Real\ exchange\ rate = \frac{Nominal\ exchange\ rate \times Domestic\ price}{Foreign\ price}$$

Source: Mankiw (2012:388)

## 2. Exchange Rates System

Exchange rates system is the system that is applied by the government to control the currency value of the exchange rate against the value of another country's currency. Understanding the exchange rate system is important because

many corporations will be affected by both economy and exchange rates. So it will be great to understand how the government can affect exchange rates.

In Indonesia, the exchange rate system will be determined by Bank Indonesia as the national central bank of Indonesia. Bank Indonesia itself has the responsibility to stabilize the exchange rates. According to Madura (2000:153), exchange rate systems are normally divided into fixed exchange rate, freely floating exchange rate, managed float exchange rate and pegged exchange rate.

a. Fixed Exchange Rate System

“In a fixed exchange rate system, exchange rates are either held with constant or allowed to fluctuate only within very narrow boundaries” (Madura, 2000:153). In this system, exchange rates don't move too much because when it did, governments will intervene within the boundaries. Fixed exchange rate system doesn't pay attention to the supply and the demand of the currency itself. At the year of 1970 until 1978, Indonesia adopted the fixed exchange rate system. The past 8 years of the system, Indonesia experience three times devaluation towards United States dollar because the value does not match the real value.

This system can cause two different conditions. First, it can be overvalued. This is where the value is set too high from the real value. Second, it can be undervalued. Occurs then the value is set too low from the real value.



b. Freely Floating Exchange Rate System

According to Madura (2000:154), freely floating exchange rate system is a system where exchange rate values are determined by market forces. This system doesn't include intervention by various governments. Freely floating exchange rate system is much more preferable than fixed exchange rate system. First, this system can respond better towards inflation problem. It will be a lot easier to adjust business with this kind of exchange rate system. Second, central bank is not required to constantly maintain exchange rate within some boundaries.

In this system, government can still implement policies, yet it's not mandatory to apply intervention policies. The policies or the actions may have an unfavorable effect on the economy. This system can make one country easier to adjust and stronger in exchange rates. But some country will get a loss from actions taken by the country related.

c. Managed Float Exchange Rate System

Based on Madura (2000:156), managed float exchange rate resembles the freedom of exchange rate to fluctuate on daily basis and an official boundary does not exist. This is the system that Indonesia used since 1998 until now. The changes in exchange rate system from freely floating to managed floating are caused by economic crisis of Indonesia and other countries in Asia. The system change is expected to be able to strengthen the rupiah although the rupiah has a tendency to weaken.

d. Pegged Exchange Rate System

Some countries use pegged exchange rate system, where their home currency's value is pegged to a foreign currency or to a unit of account. "While the home currency's value is fixed in terms of the foreign currency (or unit of account) to which it is pegged, it moves in line with that currency against other currencies" (Madura, 2000:157). Pegged exchange rate system was applied back then in 1972 within the European countries called Europe's Exchange Rate Mechanism (ERM). It was one of the best-known pegged exchange rate arrangements.

**3. Factors That Influence Exchange Rates**

The volatility of exchange rates can be caused by many factors. Several factors that can affect exchange rates according to Madura (2000:100) are relative inflation rates, relative income levels, government controls and expectations. Meanwhile according to Sukirno (2010:402), factors that can affect the exchange rates are:

a. Society taste

The society will determine the patterns of the consumptions. In this case, every time the quality of imported goods is rising, it will increase the value of imports. But when the quality of domestic goods is rising, it will decrease the value of imports. These changes can cause the supply and demand of foreign exchange rate.

b. Prices of imported and exported goods

Price is one of the important factors that influence the decision of international trading. When the price of domestic goods is relatively cheaper, it will increase the volume of exports. Vice versa, it will decrease the volume of exports when the price increases. This condition also applies to imports. When the imported goods are relatively cheaper, it will increase the volume of imports. When the price of imported goods is rising, it will decrease the volume of imports. The fluctuation of price will influence supply and demand of foreign exchange rate in country related.

c. Inflation

Inflation has a large influence on foreign exchange. Inflation that occurs in a country can reduce the value of a foreign exchange. It happens because inflation can affect domestic prices which will also affect the prices of exports and imports. The fluctuation of prices, as it mentioned before can caused fluctuations in foreign exchange demand and supply.

d. Interest rate

Interest rates have an important role in influencing capital flows. High interest rates increase the flow of capital into the country, so that the demand for a rising currency causes the exchange rate to strengthen. Low interest rates increase the flow of capital abroad, so that the demand for foreign currencies increases causing the exchange rate to weaken.

e. Economic growth

The effect that an economic progress will have on the value of its currency depends on its economic growth. Increased economic growth which resulted in increased productivity will increase sales of domestic products abroad. This situation will make demand for domestic currency increase so that the exchange rate strengthens. Economic growth which results in demand for foreign goods greater than domestic goods will reduce demand for the domestic currency so that the exchange rate weakens.

**E. The Influences between Variables**

**1. The Influence of Net Exports on Exchange Rate**

Export and import activities can affect the exchange rate of a country. According to Murni (2009:228) export and import activities will affect the amount of demand for a country's currency. Export activities, namely selling domestic goods to foreign markets, will increase the demand for the currency of the exporting country so that the currency will strengthen. The import activity is to buy goods from abroad to be consumed domestically, imports will result in an increase in the demand of the importing country's currency so that the value of the domestic currency will weaken.

It is mentioned by Salvatore (2009: 215) that exchange rate between two nations are determined by how big the goods and services trading activities between those nations. It is often called as trade approach or elasticity exchange

rate determination which can only be seen from the international trade factors, without concerning other factors such as money supply or foreign investment. The theory said that if the country's import value is greater than its export value (trade deficit), the exchange rate will increase or experience depreciation, vice versa (Ekananda, 2014:225).

Based on the previous studies by Rusdiana (2011), the net exports did not have significant partial influence towards exchange rate. Different with Muzzaky (2015), although the research only explains about export, the result showed that export have significant influence towards exchange rate. Same result is with Sedyaningrum (2016) which resulted exports have significant influence towards exchange rate. Based on the previous studies and the explanation from Salvatore (2009:405), it can be concluded that exchange rate will move according to the value of export and import that is done by a country.

## **2. The Influence of Economic Growth on Exchange Rate**

An important function of economic growth is to reflect the economic condition of a country. According to Sukirno (2010: 403) one of the factors that influence changes in exchange rates is economic growth. Sluggish economic growth allows unstable economic conditions and a non-conducive political situation as a result of which economic activities decline including production and investment activities. Economic growth can use the trade approach or elasticity of

exchange rate determination because the economic growth consists of trading activities which include export and import.

Based on the previous studies by Puspitaningrum (2013), economic growth did not have significant partial influence towards exchange rate. The same result was obtained by Sedyaningrum (2016) and Rusdiana (2011) where the economic growth as dependent variable did not have significant partial influence towards exchange rate. But the economic growth is very related to net exports, so according to trade approach the economic condition of a country can influence the country's exchange rate.

### **3. The Influence of Inflation on Exchange Rate**

Inflation has a strong influence on exchange rates. Changes in inflation can affect the demand for currencies in a country, which can also influence the pattern of international trade. It is mentioned in Madura (2000:89) that changes in inflation rates can affect a country's international trade activities. When a country's inflation increases, the demand for currency will decrease because exports also fall.

One of the most popular theories that show the influence of inflation on exchange rate is purchasing power parity (PPP) theory. According to Madura (2000:214), PPP is a picture of the exchange rate balance adjusted for the amount of difference in the level of prices between two countries, and based on PPP it can

be known the level of demand and supply of foreign currencies. There's two different kind of PPP, which are PPP absolute and PPP relative.

Salvatore (2009:473) said that “the absolute purchasing power parity theory postulates that the equilibrium exchange rate is equal to the ratio of the price level in the two nations”. Meanwhile Salvatore (2009:474) also said that “relative purchasing power parity postulates that the change in the exchange rate over period of time should be proportional to the relative change in the price levels in the two nations over the same time period”.

The PPP theory able to explain the influence of how inflation can affect the exchange rate. The previous studies that is conducted by Venkatesan, *et al* (2017), Muzzaky (2015), Puspitaningrum (2013), Widiastuti (2011) and also Rusdiana (2011) all showed that the inflation have significant influence towards exchange rate. Based on the explanation of Salvatore (2009:474) it can be concluded that when a country experience inflation, it will decrease the exchange rate of a country towards other country that did not experience inflation.

## **F. Conceptual Model**

Conceptual model is a model that is used to describe how the theory has the logical relationship and connect with the identified problems. Conceptual model will also explain the variables that are used in the research. The model later can be used to develop hypothesis model. The conceptual model is described as below:

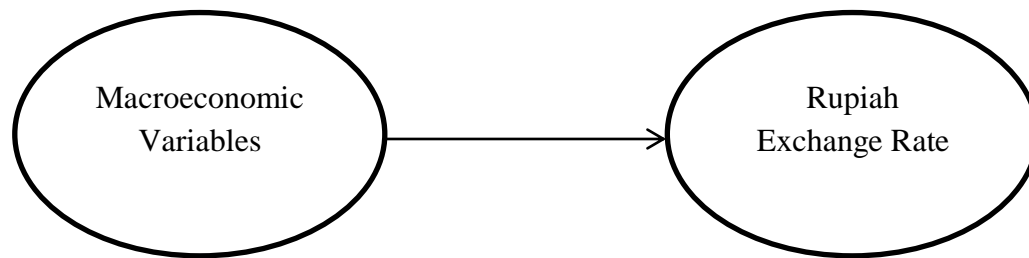
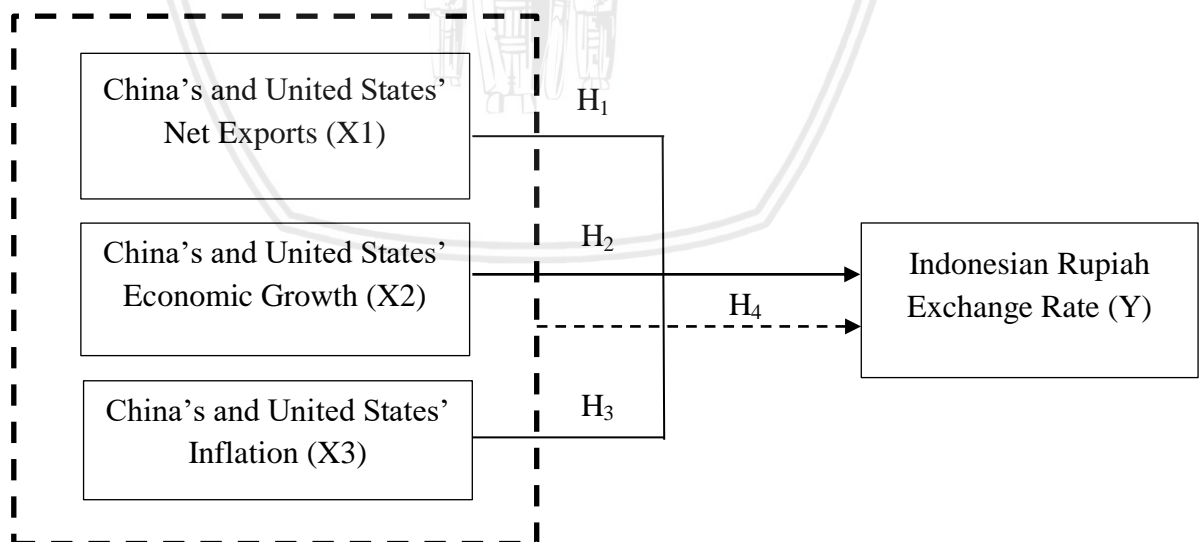

**Figure 5. Conceptual Model**

Source: Data processed by researcher, 2018

### G. Hypothesis Model

According to Noor (2011:79), “hypothesis is a temporary answer to the research question”. Meanwhile based on Sugiyono (2009:92), hypothesis is a temporary answer to a problem that is stated in a research and must be verified. Therefore, there is a connection between the hypothesis and the formulation of the problems that have been described previously in chapter I. The answer that is stated in the hypothesis must be according to the theory and previous researches.

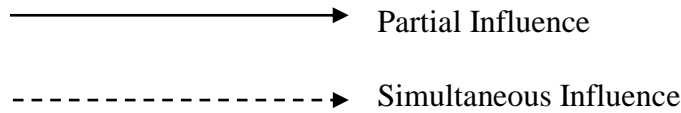

**Figure 6. Hypothesis Model**

Source: Data processed by researcher, 2018



Explanation:



The figure above shows the relationship between independent variables and dependent variable, both partially and simultaneously. Hypothesis can be proven through various tests to get the actual answer from a research. Based on the description, a temporary hypothesis can be drawn as below:

- H1 : China's and United States' net exports (X1) has a significant influence partially towards Indonesian rupiah exchange rates (Y).
- H2 : China's and United States' economic growth (X2) has significant influence partially towards Indonesian rupiah exchange rates (Y).
- H3 : China's and United States' inflation (X3) has a significant influence partially towards Indonesian rupiah exchange rates (Y).
- H4 : China's and United States' net exports (X1), economic growth (X2) and inflation (X3) has a significant influence simultaneously towards Indonesian rupiah exchange rates (Y).

## CHAPTER III

### RESEARCH METHOD

#### A. Type of Research

The method in this research will use explanatory research with quantitative approach. According to Sugiyono (2012:8), quantitative approach is research methods that are based on positivist paradigm, used to examine certain populations or samples, collecting data using research instruments, and analyzing data is statistical, with the aim of testing the hypothesis that are already set. Meanwhile, based on Creswell (2016:21) explanatory research is a study that analyzes the results and compiles it through explanation.

As it mentioned above, quantitative research is based on the positivist paradigm. Positivist paradigm means that research is based on the assumption that a symptom can be classified and causal. The research paradigm determines the pattern of the relationship between the variables studied by focusing on just a few variables (Sugiyono, 2017:65).

The method in the research will later generate data result in the form of numbers that can be measured. This research is using quantitative explanatory approach to get an overview of the independent variables on the dependent variable. The independent variables in this research are net exports, economic growth and

inflation, meanwhile the dependent variable is exchange rate. It will later explain the causal relationship between variables through testing hypothesis.

## **B. Location of Research**

Location of research is the place where researcher can get a valid and accurate data for the research. Location that researcher will use for this research is the website of International Monetary Fund ([data.imf.org](http://data.imf.org)). International Monetary Fund is an organization of 189 countries. Based on IMF website, IMF is “working to foster global monetary cooperation, secure financial stability, facilitate international trade, promote high employment and sustainable economic growth, and reduce poverty around the world.” The International Monetary Fund primary purpose is to make sure the international monetary system stabilizes, including exchange rates movement and international payments ([www.imf.org](http://www.imf.org), 2018).

Other than International Monetary Fund’s website, researcher will also use Federal Reserve Bank’s website. Federal Reserve Bank or often known as The Fed is the central bank of the United States. It provides a Research Division that is responsible for economic policy in the country. The website offers economic data and information to educate and enhance economic research ([www.federalreserve.gov](http://www.federalreserve.gov), 2017).

Researcher chooses International Monetary Fund and Federal Reserve Bank as the location of research because both organizations provide transparent and accountable data. Based on Federal Reserve Bank (2017), to ensure financial

accountability, the data are audited annually by an independent, outside auditor. It is stated that the data that is provided will be accurate and credible. Researcher also uses both organizations because it provides the complete information that supports the research. All the movement of macroeconomic variables and exchange rates between United States dollar and Indonesian rupiah are listed in both websites.

Location of research will be focused on variables related to this research. The data that will be taken at the IMF and Federal Reserve Bank's website will be focused on three countries which are China, United States and Indonesia. Independent variable in this research will use China's and the United States' data, while the dependent variable will used Indonesia's data.

### **C. Research Variable and Measurement**

According to Sugiyono (2009:60), "Research variables are basically everything in the form that is determined by the researcher to be studied so that information can be obtained about it, and then conclusions are drawn". Variables are the center of attention in the quantitative research, it become the object of research that can influence the research. The variables in this research are going to be divided into two, which is dependent variable (Y) and independent variable (X). Based on Martono (2010:61), independent variable is a variable that affects other variables or cause results in other variables. While dependent variable is variable that is affected by independent variable.

The independent variables in this research are going to be macroeconomic variables of China and United States. There are three independent variables, which are net exports ( $X_1$ ), economic growth ( $X_2$ ) and inflation ( $X_3$ ). Meanwhile, the dependent variable in this research is exchange rate ( $Y$ ) of IDR-USD. Each of the variables in this research has indicators that will be used for the measurement. Details of the variables and indicators for each variable are presented in the following table which occurs as the operational definition of variables:

**Table 2. Operational Definition of Variables**

No	Variable	Source	Operational Definition	Scale
1	Net exports ( $X_1$ )	International Monetary Fund ( <a href="http://data.imf.org/">http://data.imf.org/</a> )	Net exports (NX) are defined when the export value is reduced by the import value of a country (Mankiw, <i>et al.</i> 2014:24). Data taken are quarterly data from 2009 until 2018.  $NX = Export - Import$	Ratio
2	Economic Growth ( $X_2$ )	Federal Reserve Bank of St. Louis ( <a href="https://fred.stlouisfed.org/">https://fred.stlouisfed.org/</a> )	Economic growth can be measured as GDP or gross domestic products. Data taken are quarterly data from 2009 until 2018.	Ratio
3	Inflation ( $X_3$ )	International Monetary Fund ( <a href="http://data.imf.org/">http://data.imf.org/</a> )	Inflation rate can be measured as CPI or consumer price index. CPI is a measurement of	Ratio

**Continued Table 2. Operational Definition of Variables**

No	Variable	Source	Operational Definition	Scale
			overall cost of goods and services that is purchased by consumers (Mankiw, <i>et al.</i> 2014:24). Data taken are quarterly data from 2009 until 2018.	
4	Exchange Rates (Y)	International Monetary Fund ( <a href="http://data.imf.org/">http://data.imf.org/</a> )	Exchange rate is the currency of another country from an economic condition (Manurung, <i>et al.</i> 2008:91). Data taken are quarterly data from 2009 until 2018, and exchange rate will be between Indonesian Rupiah and US Dollar.	Ratio

Source: Data processed by researcher, 2018

## D. Research Population and Sample

### 1. Population

Population is the whole object or subject that is in an area and fulfills certain requirements relating to research problems (Martono, 2010:76). Population is not only the number of object or subject studied but also concerns the nature and characteristics. The population in this research is all quarterly time series data of

China's and United States' net exports, economic growth, inflation and Indonesian rupiah exchange rates for 10 years period from 2009-2018.

## 2. Sample

According to Sugiyono (2012:81) sample is a part of the total and characteristics of the population. The sampling technique that will be used in this research is non-probability sampling, with saturated sampling method. Saturated sampling method is a method where all the members of the population are used as the sample of the research itself. This research is using saturated sampling due to the availability of the data are only during the period of the research.

Samples in this research are going be 10 years quarterly data, which includes data of China's and United States' net exports, GDP, inflation, and also Indonesian rupiah exchange rates. Based on these data, the numbers of samples in this research are 76 samples. It is obtained from quarterly data for 10 years, from 2 different countries which is China and United States. Data will be taken from quarter I 2009 until quarter II 2018. Researcher could not fulfill all the quarter data in 2018 due to availability of the data.

**Table 3. Population and Sample**

No.	Explanation	Total
1.	Quarter time series data of GDP, inflation and net exports in China 2009-2018.	38
2.	Quarter time series data of GDP, inflation and net exports in United States 2009-2018.	38
3.	Total quarter time series data of China & United States 2009-2018	76

**Continued Table 3. Population and Sample**

No.	Explanation	Total
	Total samples (n) that will be used in this research using saturated sampling 4 quarter x 2 countries x 10 years	76

Source: Data processed by researcher, 2018

### **E. Data Collection Technique**

Data collection techniques are a way to collect data needed to answer the research problem formulation (Noor, 2011:138). Using the right data collection technique will help the researcher on gathering accurate data and it will make it easier to proceed. This research will be using documentation technique where researcher takes data systematically from records that are consist of phenomenon of an object or subject that are being studied. This technique looks to the secondary data that is provided by International Monetary Fund and Federal Reserve Bank. The data collected for this research are financial reports of China's and United States' net exports, economic growth and inflation, also Indonesian rupiah exchange rate.

### **F. Data Analysis Technique**

#### **1. Descriptive Statistical Analysis**

The analysis technique that is used in this research is statistical descriptive. Based on Siregar (2016:2), descriptive statistics are statistics that related on how to describe, picture, elaborate data so it is easy to understand. One of the functions



of descriptive statistical analysis is to classify a variable so it can be interpreted by the researcher.

Other than that statistical descriptive analysis also provides information, so the data that is gathered and resulted from the research can be used for other researcher that needs the information. The data that is gathered in this research will be processed and served in a form that is easy to understand by data user. Results of a quantitative research using the descriptive statistical analysis usually will be formed as numbers and graphic.

## **2. Classic Assumption Test**

According to Sanusi (2014:135), a multiple linear regression must fulfill the classic assumptions set so that the results of the coefficient values as estimators are not biased. The classic assumptions consist of normality test, multicollinearity test, heteroscedasticity test and autocorrelation test. The classic assumption test is done to find out whether or not there are irregularities or deviation in the classical assumption. If there are irregularities and deviations after being tested, it is proven that the regression model is biased.

### **a. Multicollinearity Test**

This test aims to see whether the independent variables correlate with one another or not. This often happens in time series data, meanwhile a good regression model are the ones that did not have multicollinearity. According to Sudarmanto (2013:224), multicollinearity occurs when there is a linear

relationship between independent variables. When it happens, then the regression coefficient cannot be estimated and the influence of each variable is difficult to distinguish (Supranto, 2016:278).

The perfect method to do this test is using correlation test between independent variables called Variance Inflation Factor (VIF) and Tolerance Value. According to Ghozali (2006:91), the decision making that will be used will be based on:

- 1) If Variance Inflation Factor  $> 10$  and Tolerance value  $< 0.1$  then the model regression has multicollinearity.
- 2) If Variance Inflation Factor  $< 10$  and Tolerance value  $> 0.1$  then the model regression free from multicollinearity.

b. Autocorrelation Test

According to Ghozali in Muzzaky (2015) autocorrelation test aims to find out whether a regression model has a correlation relationship on residual in period  $t$  and period  $t-1$ . If there is a correlation relationship, the regression model that is done cannot be classified as a good regression model. The right way to check autocorrelation is to use the Durbin-Watson  $d$  statistical method. Based on Ghozali (2006:120), the decision making will be based on:

- 1) If  $d < d_l$  or  $d > 4-d_l$ , then there is an autocorrelation between the residual value.
- 2) If  $d_u < d < 4-d_u$ , then there is no autocorrelation between the residual value.

c. Heteroscedasticity Test

Heteroscedasticity test aims to check whether the regression analysis is obtained by assuming the confounding variable has a constant variant (Sudarmanto, 2013:240). Using chart which conducted by seeing the dot pattern in the scatterplot chart can help identifying the heteroscedasticity. According to Ghozali (2006:105), the decision making will be based on:

- 1) If there are certain patterns such as dots that form a regular pattern, it indicates heteroscedasticity has occurred.
- 2) If there is no clear pattern, as well as points that spread above and below point 0 and the Y axis, heteroscedasticity does not occur.

d. Normality Test

Normality test is a test that ensures feasibility of the data to be analyzed using parametric or nonparametric statistics (Misbahuddin, 2013:278). Normality test is required to test the data of independent variable (x) and dependent variable (Y) in a regression equation, whether it is normally distributed or not normally distributed. Normality test can be checked using many different types of other testing, one of the tests consist of Kolmogorov-Smirnov test. According to Misbahuddin (2013:281), the basic of decision making will be based on the criteria below:

- 1) If significant value  $\geq$  real level, then the distribution data is normal.
- 2) If significant value  $<$  real level, then the distribution data is not normal.

### 3. Inferential Statistical Analysis

According to Sugiyono (2013:208), inferential statistics is a statistical technique used to analyze sample data and the results that will be applied to the research population. Inferential statistics require the fulfillment of assumptions. This is necessary because inferential statistics need to represent a sample of the population. The assumptions that need to be fulfilled follow the analysis tools used. If the regression analysis is used, then the data assumptions must meet the assumptions of the regression analysis.

#### a. Multiple Linear Regressions Analysis

Multiple linear regressions are the analysis that determines the relationship between dependent variable and independent variable by using linear equation. Based on Misbahuddin (2013:159), multiple linear regressions are used to test the significance of two variables through the regression coefficient. Multiple linear regressions are used in this research because the variables used in this research are more than one, and the equation is as stated as below:

$$Y = b_0 + b_1 X_1 + b_2 X_2 + b_3 X_3 + e$$

Source: Misbahuddin (2013:159)

Explanation:

Y = exchange rate

$b_0$  = constant

- $b_1$  = regression coefficient of net exports
- $b_2$  = regression coefficient of economic growth
- $b_3$  = regression coefficient of inflation
- $X_1$  = net exports
- $X_2$  = economic growth
- $X_3$  = inflation
- $e$  = error term, the error level of guesser in the research

b. Simultaneous Test (F test)

Simultaneous test or the f test has a purpose to identify whether the independent variables have a significant influence on dependent variable simultaneously or not (Sanusi, 2014:137). This test is conducted to test the hypothesis, which can be described as follows:

- 1)  $H_0 : b_i = 0, i = 1, 2, 3$  means that there is no significant influence among independent variables on dependent variable.
- 2)  $H_a : b_i \neq 0, i = 1, 2, 3$  means that there is significant influence among independent variables on dependent variable.

F test is performed by comparing the significant of F (sig. F) and level of significant ( $\alpha$ ), and then it will be known if the hypothesis is accepted or rejected, by seeing:

- 1) Sig. F < level of significance ( $\alpha$ ) :  $H_0$  rejected
- 2) Sig. F > level of significance ( $\alpha$ ) :  $H_0$  accepted

c. Partial Test (T test)

Partial test or t test, is conducted to identify if there is a significant influence among each independent variable on dependent variable or not (Sanusi, 2014:138). T test is conducted to test this hypothesis:

1)  $X_1$  variable on Y

$H_0 : b_1 = 0$ , means that there is no significant influence of  $X_1$  variable on Y variable.

$H_a : b_1 \neq 0$ , means that there is a significant influence of  $X_1$  variable on Y variable.

2)  $X_2$  variable on Y

$H_0 : b_2 = 0$ , means that there is no significant influence of  $X_2$  variable on Y variable.

$H_a : b_2 \neq 0$ , means that there is a significant influence of  $X_2$  variable on Y variable.

3)  $X_3$  variable on Y

$H_0 : b_3 = 0$ , means that there is no significant influence of  $X_3$  variable on Y variable.

$H_a : b_3 \neq 0$ , means that there is a significant influence of  $X_3$  variable on Y variable.

T test is conducted by comparing significance of t (Sig.t) and level of significance ( $\alpha$ ) with value  $\alpha = 0,05$ , thus it can be known if the hypothesis are accepted or rejected by:

- 1) Sig.  $t < \text{level of significance } (\alpha) : H_0 \text{ rejected}$
- 2) Sig.  $t > \text{level of significance } (\alpha) : H_0 \text{ accepted}$

d. Coefficient Determination Analysis

Determination coefficient analysis is applied to measure the level of the relationship between the dependent variable and all the independent variables that explain together and the value is always positive (Sanusi, 2014:136). According to Algifari (2009:45) the coefficient of determination shows the percentage variation in the value of the dependent variable that can be explained by the resulting regression equation. Determination coefficient  $R^2$  (adjusted R square) can be seen in the model summary that is given from data output.

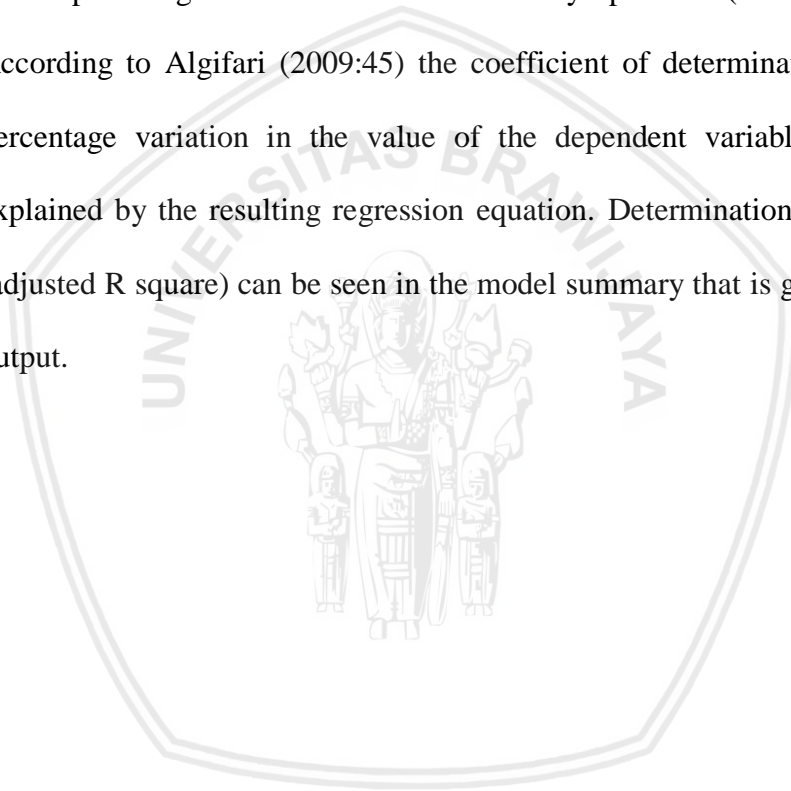

## CHAPTER IV

### RESULT AND DISCUSSION

#### A. General Description of Country

##### 1. Indonesia Overview

Based on The World Factbook in Central Intelligence Agency (2019), Indonesia is a country which located in Southeast Asia, with DKI Jakarta as the capital and the largest city of the country. Indonesia has an area of 1,904,569 km<sup>2</sup> with 34 provinces and human population of approximately 266 million people. The government that is used in Indonesia is republic and has unitary presidential. Indonesian Rupiah (IDR) is the nation currency and Bahasa Indonesia is the official language of the country.

##### 2. China Overview

According to The World Factbook in Central Intelligence Agency (2019), People's Republic of China, or mostly called China is a country located in East Asia. China has an area of 9,596,960 km<sup>2</sup> with Beijing as the capital city and Shanghai as the largest city of the country. The government that China implement in the country is unitary one-party socialist republic. China is the most populated country with approximately 1,403,500,365 people. The nation currency of China is Renminbi (CNY) and Chinese is the official language of the country.



### 3. The United States Overview

According to The World Factbook in Central Intelligence Agency (2019), the United States of America, known as the United States or America, is a country with 9,833,517 km<sup>2</sup> total area. The capital city of the United States is Washington D.C, and New York City as the largest city of the country. Federal presidential constitutional republic is the government that the United States implement. The nation's currency is United States dollar (USD) and English is the national language. The United States is populated with 327,167,434 soul, which ranked the 3<sup>rd</sup> largest country population.

## B. General Description of Research Location

### 1. International Monetary Fund Overview



**Figure 7. International Monetary Fund Logo**

Source: [www.imf.org](http://www.imf.org) (2019)

IMF which stands for International Monetary Fund is a worldwide organization that consists of 189 countries as the members. According to the IMF (2019), it first established on July 1944 at a United Nation conference located in

Bretton Woods, New Hampshire, United States and officially created in 1945. The IMF played an important part in shaping the global economy since the end of World War II. At the first conference, the IMF builds a framework for economic cooperation to avoid competitive devaluations that was currently happening at that time. The job was to rebuild national economies, by overseeing the monetary system to ensure exchange rate stability and encourage members to eliminate restrictions that hinder trade.

The current IMF headquarters is located in Washington D.C. Nowadays the IMF has 5 primary aims that the organization want to achieve. The IMF aims to promote international monetary cooperation, facilitate the expansion and balanced growth of international trade, promote exchange stability, assist in the establishment of a multilateral system of payments, and make resource available to members experiencing balance of payments difficulties. The IMF itself has 24 directors each representing a single or groups of countries as the executive board, with approximately 2700 staffs from 150 countries.

The IMF has three ways to achieve the organization's fundamental mission. The first one is keeping track of the global economy and the economies of member countries by doing surveillance. The organization monitors the economic and financial policies of its members and the IMF takes a part where it highlights some possible risks and advises on needed policy adjustment.

Second, the IMF lend to countries with balance of payments difficulties. The organization provides loans to help them rebuild the member's international

reserves, stabilize the currencies, restore condition to achieve strong economic growth while correcting the underlying problems. The IMF is able to lend to its member countries up to one trillion dollar. The last one is capacity development where the IMF works with government around the world to modernize some economic policies and train the people. The organization believes that it will strengthen and improve the economy, growth yet also create jobs.

Other than what was mentioned before, the IMF also has various committees, groups and clubs. Leaders and officials from all over the world forms different forums and bodies to shape the work of the IMF. Based on the IMF (2019), “with the IMF at the center of the coordinated global response to events in international financial markets and the world’s economies, understanding what these groups do and how they work is important”.

## 2. The Federal Reserve Bank Overview



**Figure 8. The Fed Logo**

Source: [www.federalreserve.gov](http://www.federalreserve.gov) (2019)

The Federal Reserve System or simply “the Fed” is the central bank of the United States. Based on the Fed (2017), the organization was created on December 23<sup>rd</sup>, 1913 by the Congress to provide the nation with a safer, more flexible and more stable monetary and sustainable financial system. It was signed into the law by President Woodrow Wilson and firstly named the Federal Reserve Act. The Fed currently has 12 Federal Reserve Banks as the organization key entities, which located in various different districts in major cities throughout the nation. The 12 districts are Boston, New York, Philadelphia, Cleveland, Richmond, Atlanta, Chicago, St. Louis, Minneapolis, Kansas City, Dallas and San Francisco.

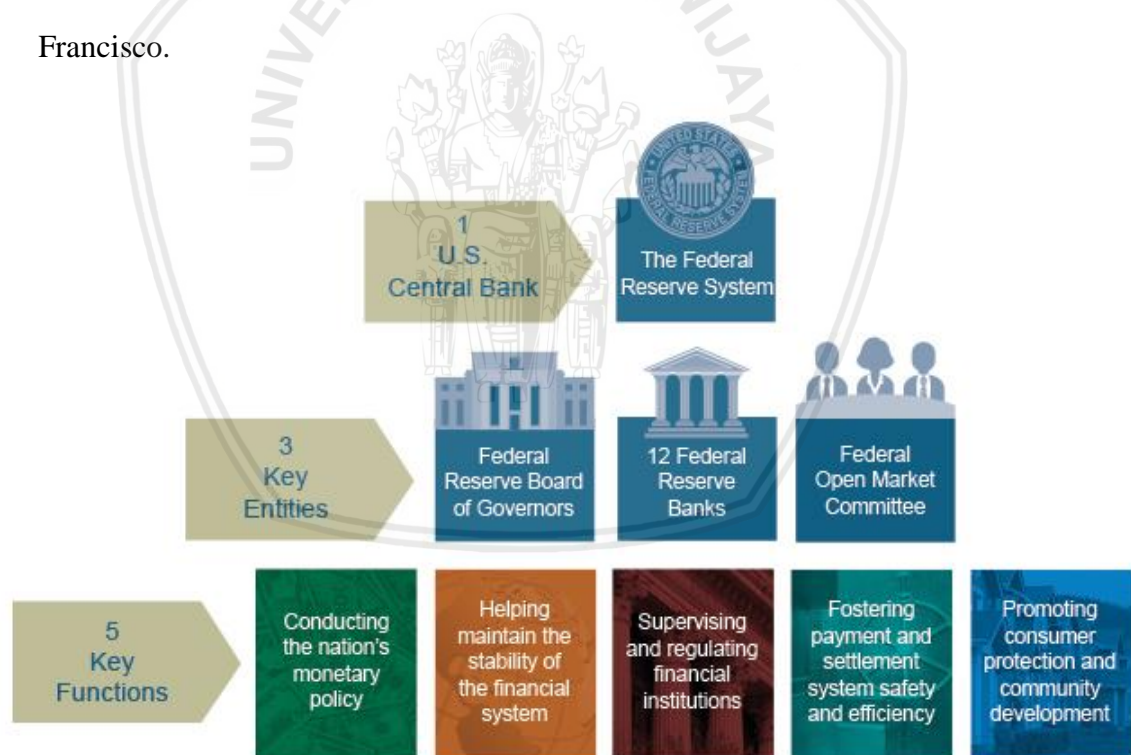

**Figure 9. Structure of the Federal Reserve System**

Source: [www.federalreserve.gov](http://www.federalreserve.gov) (2019)

Based on the picture above, the Fed performs five general functions to show the effectiveness of United States economy operations. It is the main job description that The Fed does for the nation. The five general functions are as follows:

- a. conducts the nation's monetary policy to promote maximum employment, stable prices, and moderate long-term interest rates in the U.S. economy;
- b. promotes the stability of the financial system and seeks to minimize and contain systemic risks through active monitoring and engagement in the U.S. and abroad;
- c. promotes the safety and soundness of individual financial institutions and monitors their impact on the financial system as a whole;
- d. fosters payment and settlement system safety and efficiency through services to the banking industry and the U.S. government that facilitate U.S. dollar transactions and payments; and
- e. Promotes consumer protection and community development through consumer-focused supervision and examination, research and analysis of emerging consumer issues and trends, community economic development activities, and the administration of consumer laws and regulations.  
(www.federalreserve.gov, 2017)

### **C. Descriptive Statistical Analysis**

Descriptive statistical analysis is one of the methods used in explanatory research. This analysis is used to simplify, summarize and explain the data that will be examine. According to Sanusi (2014:116) descriptive measures that are often used to describe research are frequencies and averages. In this research the descriptive statistical analysis will show the mean, standard deviation and also the general description of the research data.

There will be 4 variables in this research which are net exports, economic growth, and inflation of China and United States as the independent variables.

Meanwhile, Indonesian rupiah exchange rates will be the dependent variable. The descriptive statistical analysis will be conducted by using Microsoft Excel 2016. The result of this analysis will show descriptive statistics from the sample, where the sample in this research will be a time series data of 10 years period from 2009 quarter I until 2018 quarter II. The description from each of the research variable will be mentioned as follows:

### 1. Net Exports

**Table 4. Net Exports of China (in million USD) 2009:I-2018:II**

Q	2009	2010	2011	2012	2013	2014	2015	2016	2017	2018
I	62,247	13,889	-2,281	194	43,549	16,584	123,732	125,736	66,112	49,118
II	33,898	41,045	46,344	68,390	65,711	85,939	139,541	143,442	121,579	94,774
III	38,326	64,863	62,577	79,184	61,554	128,100	163,607	144,254	117,250	
IV	61,153	61,708	48,258	83,322	90548	149,494	174,777	133,812	133,084	
Mean				82642.350						
Maximum				174777.365						
Minimum				-2281						
Standard Deviation				46326.87126						

Source: Data processed by researcher, 2019

From the previous table, it can be concluded that the initial value of China's net exports in this research was 62,247 million dollars in the first quarter of 2009, while the net exports final value in this research was 94,774 million dollars in the second quarter of 2018. The highest China's net exports was 174,777 million dollars in the fourth quarter of 2015. The lowest China's net exports was deficit 2,281 million dollars in the first quarter of 2011. The mean of the net exports

above is 82,542 million dollar and the standard deviation is 46,326. From the data above, it can be shown that net exports of China are as figured as the graphic below:



**Figure 10. Graphic of China's net exports (in million USD)**

Source: Data processed by researcher, 2019

Meanwhile, the net exports of United States from quarter I year 2009 until quarter II year 2018 will be stated in the table below:

**Table 5. Net Exports of United States (in million USD) 2009:I-2018:II**

Q	2009	2010	2011	2012	2013	2014	2015	2016	2017	2018
I	-	-	-	-	-	-	-	-	-	-
	118,527	143,381	171,705	185,290	168,802	174,458	186,448	181,006	192,715	213,427
II	-	-	-	-	-	-	-	-	-	-
	122,014	176,645	200,308	203,791	190,559	206,079	203,361	198,277	217,471	224,998

**Continued Table 5. Net Exports of United States (in million USD) 2009:I-2018:II**

Q	2009	2010	2011	2012	2013	2014	2015	2016	2017	2018
III	- 154,604	- 199,051	- 214,133	- 210,688	- 209,443	- 218,060	- 220,443	- 214,697	- 223,981	
IV	- 154,109	- 172,312	- 197,370	- 190,895	- 181,187	- 200,860	- 202,308	- 204,940	- 228,035	
Mean				-191483.645						
Maximum				-118526.795						
Minimum				-228034.816						
Standard Deviation				26687.971						

Source: Data processed by researcher, 2019

From the table above, it can be concluded that the initial value of United States' net exports in this research was deficit 118,527 million dollars in the first quarter of 2009, it was also the highest net exports value of United States. Meanwhile the net exports final value in this research was deficit 224,998 million dollars in the second quarter of 2018. The lowest United States' net exports was deficit 228,034 million dollars in the fourth quarter of 2017.

The mean of United States' net exports above is negative 191,483 million dollar. The data also shows that it has standard deviation of 26,687. From the data above, it can be seen that net exports of United States are as figured as the graphic below:



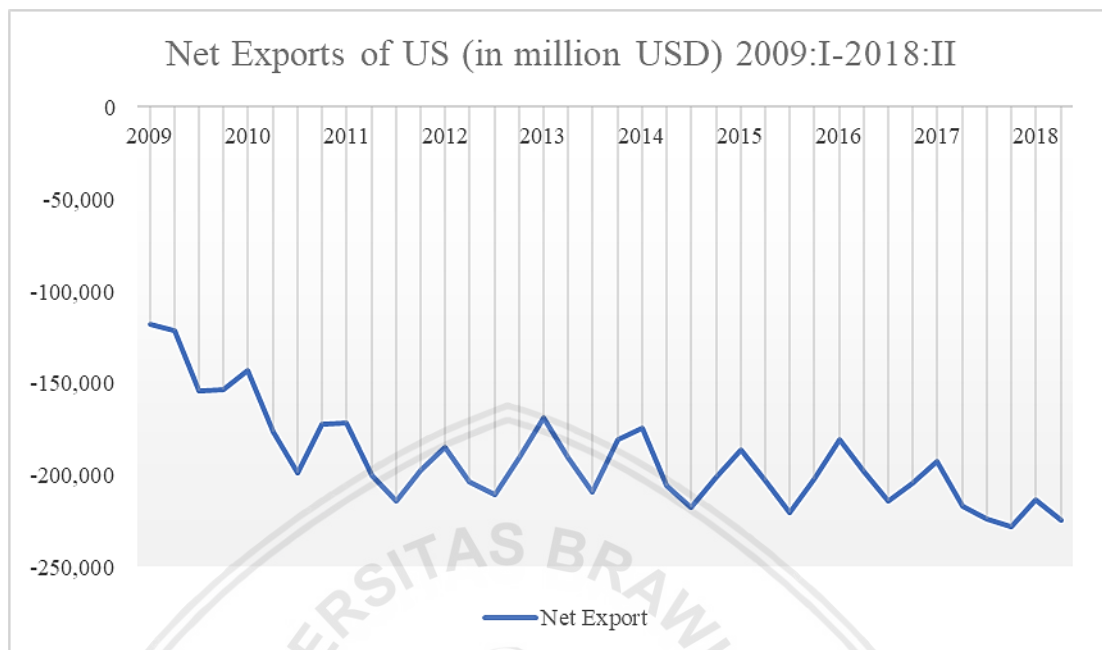

**Figure 11. Graphic of United States’ net exports (in million USD)**

Source: Data processed by researcher, 2019

## 2. Economic Growth

Economic growth in this research will be measured using gross domestic product (GDP) of each country related. The GDP of China and United States will be stated in table 6 and table 7:

**Table 6. GDP of China (in million yuan) 2009:I-2018:II**

<b>Q</b>	<b>2009</b>	<b>2010</b>	<b>2011</b>	<b>2012</b>	<b>2013</b>	<b>2014</b>	<b>2015</b>	<b>2016</b>	<b>2017</b>	<b>2018</b>
<b>I</b>	7,397,920	8,750,130	10,446,990	11,735,760	12,944,960	14,027,020	15,059,380	16,096,730	17,940,340	19,792,000
<b>II</b>	8,386,580	9,934,740	11,889,590	13,132,060	14,351,870	15,592,230	16,787,450	17,987,870	19,917,780	21,929,540
<b>III</b>	8,984,690	10,596,370	12,656,220	13,808,960	15,222,270	16,489,780	17,580,380	18,933,760	20,982,410	
<b>IV</b>	10,082,580	11,930,680	13,801,210	15,181,200	16,777,230	18,019,030	19,172,080	20,987,720	23,234,900	
Mean				14961642.370						
Maximum				23234900						
Minimum				7397920						
Standard Deviation				4109702.393						

Source: Data processed by researcher, 2019

From table 6 above, it can be concluded that the initial value of China's GDP in this research was 7,397,920 million yuan in the first quarter of 2009. While the GDP final value in this research was 21,929,540 million yuan in the second quarter of 2018. The highest China's GDP was 23,234,900 million yuan in the fourth quarter of 2017. The lowest China's GDP was 7,397,920 million dollars in the first quarter of 2009.

The mean of the GDP above is 14,961,642.370 million yuan. The standard deviation of the GDP is 4,109,702.393. From the data, it can be seen that GDP of China are as figured as the graphic below:

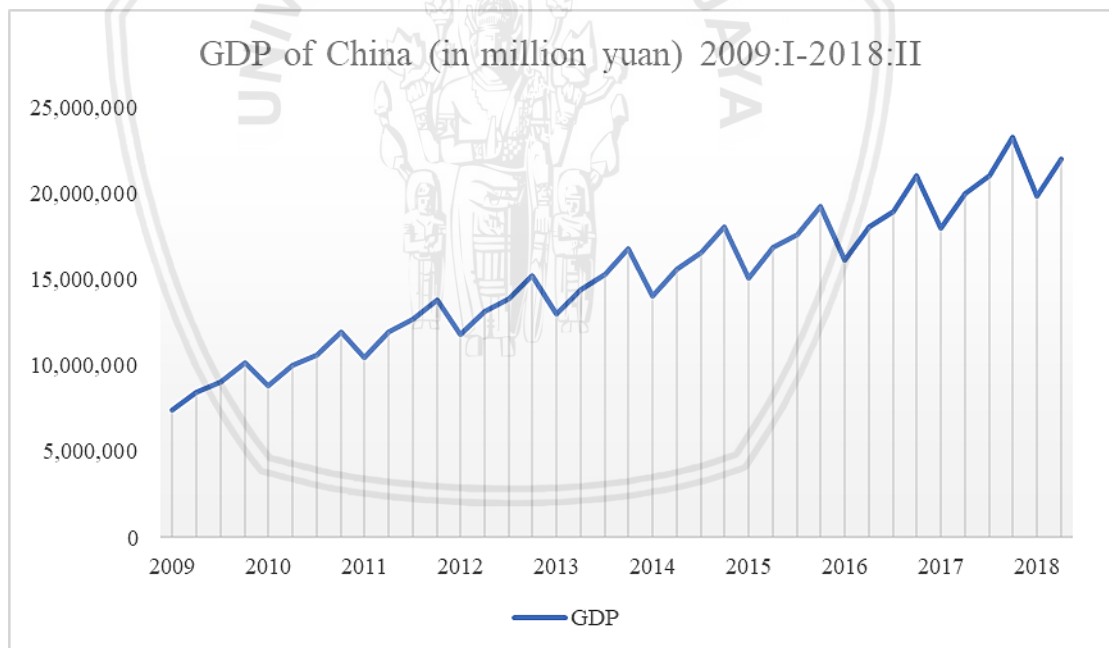

**Figure 12. Graphic of China's GDP (in million yuan)**

Source: Data processed by researcher, 2019

**Table 7. GDP of United States (in million USD) 2009:I-2018:II**

<b>Q</b>	<b>2009</b>	<b>2010</b>	<b>2011</b>	<b>2012</b>	<b>2013</b>	<b>2014</b>	<b>2015</b>	<b>2016</b>	<b>2017</b>	<b>2018</b>
<b>I</b>	3,598,637	3,680,338	3,821,457	4,004,940	4,142,398	4,275,733	4,492,606	4,602,283	4,790,638	5,010,262
<b>II</b>	3,588,213	3,731,525	3,874,047	4,038,064	4,159,482	4,356,442	4,555,325	4,660,183	4,839,781	5,102,981
<b>III</b>	3,605,078	3,769,979	3,897,963	4,064,288	4,212,187	4,429,959	4,582,773	4,699,912	4,897,019	
<b>IV</b>	3,657,005	3,810,211	3,949,115	4,089,716	4,270,784	4,459,614	4,588,593	4,744,811	4,957,957	
Mean				4263481.395						
Maximum				5102981						
Minimum				3588212.5						
Standard Deviation				448337.266						

Source: Data processed by researcher, 2019

From table 7 above, it can be concluded that the initial value of United States' GDP in this research was 3,598,637 million dollars in the first quarter of 2009. The GDP final value in this research was 5,102,981 million dollars in the second quarter of 2018, and that is also the highest United States' GDP value. The lowest United States' GDP was 3,588,213 million dollars in the second quarter of 2009.

The mean of the GDP above is 4,263,481.395 million dollars. The standard deviation is 448,337.266. From the data, it can be seen that GDP of United States are as figured as the graphic below:

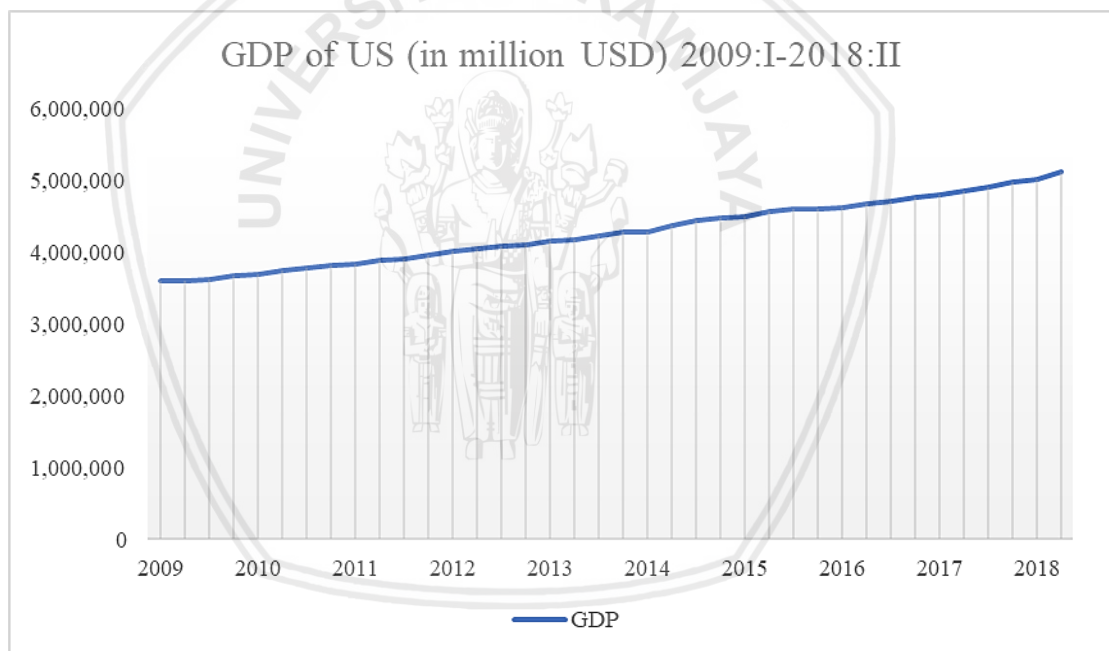

**Figure 13. Graphic of United States' GDP (in million USD)**

Source: Data processed by researcher, 2019

### 3. Inflation

Inflation in this research will be measured using consumer price index (CPI) of each country related. The CPI of China and United States will be stated as follows:

**Table 8. CPI of China 2009:I-2018:II**

Q	2009	2010	2011	2012	2013	2014	2015	2016	2017	2018
I	97.25	99.27	104.45	108.35	111.02	113.5	114.81	117.22	118.91	121.43
II	96.51	99.13	105.04	107.95	110.53	112.89	114.42	116.84	118.6	120.63
III	96.54	99.69	106.11	108.13	111.08	113.2	115.23	117.11	118.98	
IV	97.38	101.9	106.61	108.85	112.01	113.58	115.23	117.72	119.86	
Mean				110.2094						
Maximum				121.430						
Minimum				96.510						
Standard Deviation				7.558347434						

Source: Data processed by researcher, 2019

From the table above, it can be concluded that the initial value of China's CPI in this research was 97.25 in the first quarter of 2009. Meanwhile the final value of CPI in this research was 120.63 in the second quarter of 2018. The highest China's CPI was 121.43 in the first quarter of 2018. The lowest China's CPI was 96.51 in the second quarter of 2009.

The mean of the CPI above is 110.209. The standard deviation of CPI above is 7.558. From the data, it can be seen that CPI of China are as figured as the graphic below:



**Figure 14. Graphic of China's CPI**

Source: Data processed by researcher, 2019

Meanwhile, the CPI of United States from quarter I year 2009 until quarter II year 2018 will be stated in the table below:

**Table 9. CPI of United States 2009:I-2018:II**

Q	2009	2010	2011	2012	2013	2014	2015	2016	2017	2018
I	97.23	99.52	101.66	104.52	106.28	107.77	107.7	108.87	111.63	114.1
II	98.26	100	103.43	105.38	106.85	109.04	109	110.14	112.24	115.28
III	98.93	100.09	103.85	105.61	107.25	109.17	109.29	110.51	112.68	
IV	99.13	100.39	103.69	105.65	106.96	108.29	108.79	110.75	113.1	
Mean				106.3955263						
Maximum				115.28						
Minimum				97.23						
Standard Deviation				4.815015196						

Source: Data processed by researcher, 2019

From the previous table, it can be concluded that the initial value of United States' CPI in this research was 97.23 in the first quarter of 2009. Meanwhile the final value of CPI in this research was 115.28 in the second quarter of 2018. The highest United States' CPI was 115.28 same as the final value of the CPI. The lowest United States' CPI was 97.23 same as the initial value of the CPI.

The mean of the CPI above is 106.395. The standard deviation of the CPI above is 4.815. From the data, it can be seen that CPI of United States are as figured as the graphic below:

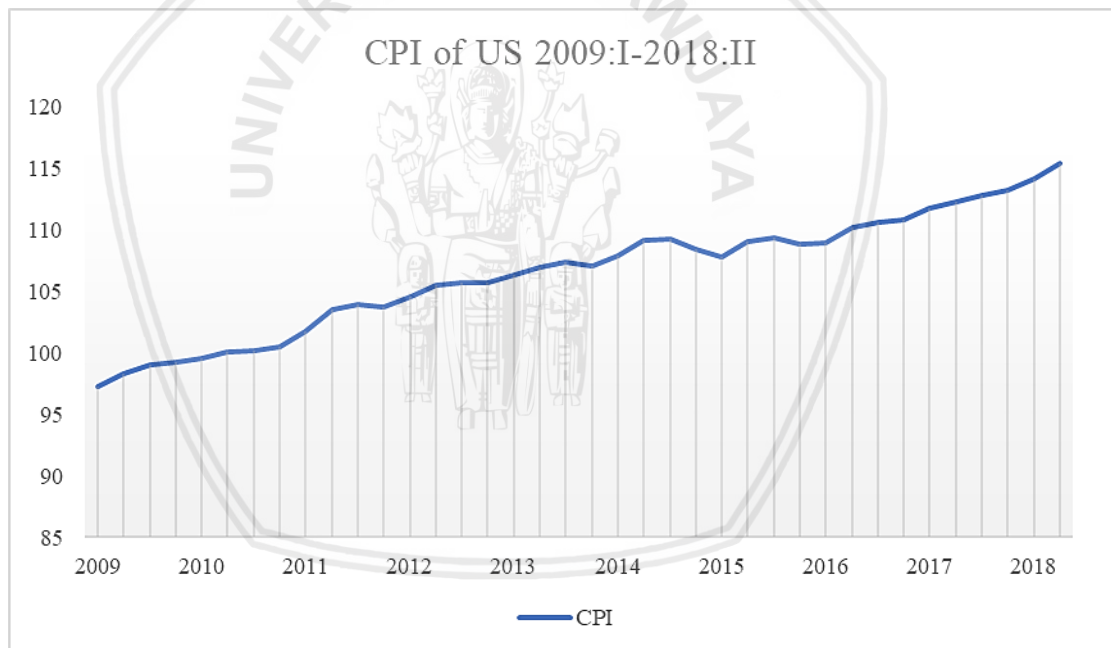

**Figure 15. Graphic of United States' CPI**

Source: Data processed by researcher, 2019



#### 4. Exchange Rate

Exchange rate that will be used in this research will be between Indonesian rupiah and United States dollar in the 10 years period from 2009-2018. The exchange rate between IDR-USD of Indonesia will be stated in table below:

**Table 10. Exchange Rate IDR-USD 2009:I-2018:II**

Q	2009	2010	2011	2012	2013	2014	2015	2016	2017	2018
I	11,575	9,115	8,709	9,180	9,719	11,404	13,084	13,276	13,321	13,756
II	10,225	9,083	8,597	9,480	9,929	11,969	13,332	13,180	13,319	14,404
III	9,681	8,924	8,823	9,588	11,613	12,212	14,657	12,998	13,492	
IV	9,400	8,991	9,068	9,670	12,189	12,440	13,795	13,436	13,548	
Mean				11346.89474						
Maximum				14657						
Minimum				8597						
Standard Deviation				1998.718965						

Source: Data processed by researcher, 2019

From table 10, it is explained that the initial value of exchange rate in this research was 11,575 in the first quarter of 2009. Meanwhile the final value of exchange rate in this research was 14,404 in the second quarter of 2018. The highest exchange rate was 14,657 in the third quarter of 2015. The lowest exchange rate was 8,597 in the second quarter of 2011.

The mean of the exchange rate above is 11,346.894. The standard deviation of exchange rate above is 1,998.718. From the data, it can be seen that exchange rate between IDR and USD are as figured as the graphic below:

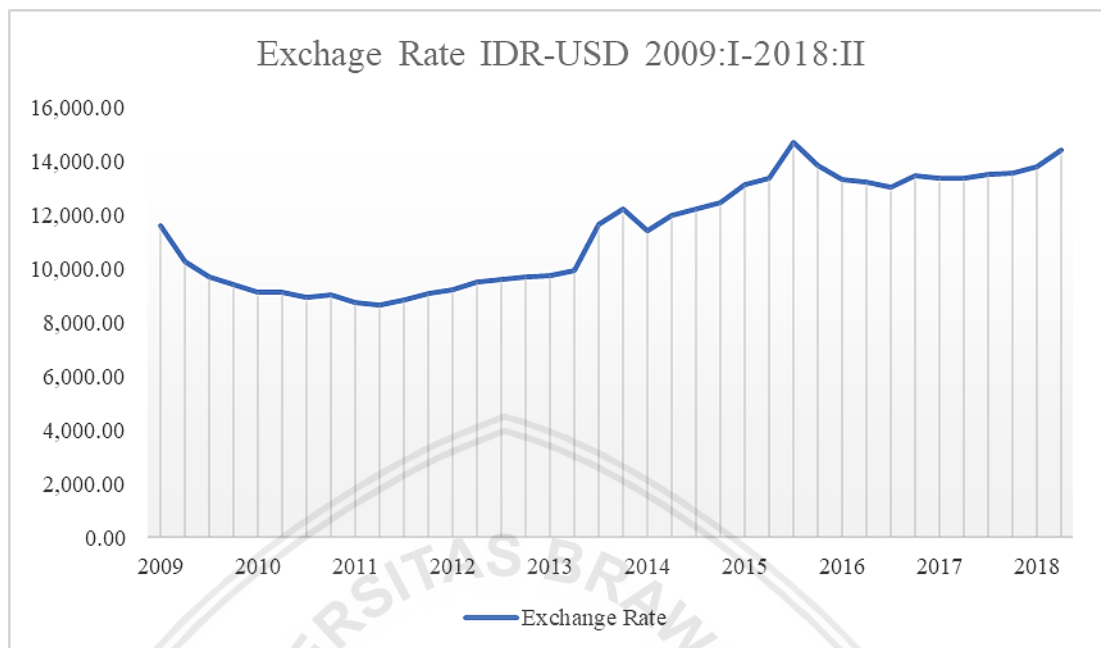

**Figure 16. Graphic of IDR-USD Exchange Rate**

Source: Data processed by researcher, 2019

#### D. Classic Assumption Test

The classic assumption test is done to find out whether or not there are irregularities or deviation in the classical assumption. The classic assumption test will be divided into multicollinearity test, autocorrelation test, heteroscedasticity test and normality test. The classic assumption test will be conducted by using SPSS 23.0.

##### 1. Multicollinearity Test

According to Sudarmanto (2013:224), multicollinearity test aims to check a linear relationship between independent variables. A good regression model are the ones that did not have multicollinearity, and it often happens in time series data. The presence or absence of multicollinearity can be seen if tolerance values

$< 0.1$  and VIF values  $> 10$  so that multicollinearity occurs. Vice versa, when tolerance values  $> 0.1$  and VIF  $< 10$  it can be said that multicollinearity does not occur.

**Table 11. Result of Multicollinearity Test**

Variable	Collinearity Statistics	
	Tolerance	VIF
Net Exports	0,929	1,077
GDP	0,943	1,060
CPI	0,983	1,017

Source: Appendix 8

Table 11 shows the result of multicollinearity test of the variables. From all the variables tested, the tolerance values are all more than 0,10 and the VIF are all less than 10. Net exports have 0,929 as the tolerance value and 1,077 as the VIF, meanwhile GDP has 0,943 as the tolerance value and 1,060 as the VIF. Lastly, CPI has 0,983 as the tolerance value and 1,017 as the VIF. Based on the description shown above, it can be concluded that the output indicates no multicollinearity occurs in the regression model.

## 2. Autocorrelation Test

Based on Ghozali in Muzzaky (2015), the autocorrelation test aims to test whether in the linear regression model there is a correlation between the confounding errors in period  $t$  and the disturbing errors in the  $t-1$  period (before). This research will be using Durbin-Watson test to know whether or not the

autocorrelation occurs in the regression model. The result of the autocorrelation test will be shown in table 12.

**Table 12. Result of Autocorrelation Test**

Model	Durbin-Watson
1	1.954

Source: Appendix 8

From the table above, autocorrelation test towards exchange rate as the dependent rate produce a statistical Durbin-Watson test value of 1,954. To prove that there is no autocorrelation occurs, the Durbin-Watson value should be between  $du$  and  $4-du$ . The  $du$  value is 1.7104, and the  $4-du$  value is 2.2896. It can be concluded that there is no autocorrelation occurs because the Durbin-Watson value is located between 1.7104 and 2.2896.

### 3. Heteroscedasticity Test

Heteroscedasticity test aims to check whether the regression analysis is obtained by assuming the confounding variable has a constant variant (Sudarmanto, 2013:240). The result of heteroscedasticity test can be shown by seeing the output of scatterplot graphic. The scatterplot graphic can be seen with the help of SPSS. The graphic will be shown in figure 10.

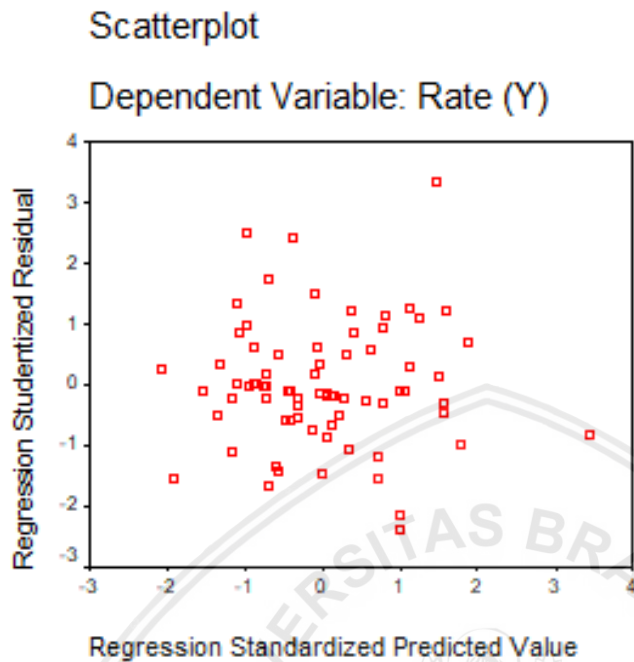

**Figure 17. Scatterplot Graphic**

Source: Appendix 9

Based on the graphic above, it can be concluded that there is no heteroscedasticity occurs in the regression model. The graphic in figure 10 did not show clear pattern. The points in the graphic spreads above and below point 0 and the Y axis.

#### 4. Normality Test

Normality test is required to test the data of independent variable and dependent variable in a regression equation, whether it is normally distributed or not normally distributed. One of the tests to check normality is by using Kolmogorov-Smirnov test. The normality test result of the research will be shown in table 13.

**Table 13. Result of Kolmogorov-Smirnov Test**

**One-Sample Kolmogorov-Smirnov Test**

		Standardized Residual
N		76
Normal Parameters <sup>a,b</sup>	Mean	,0000000
	Std. Deviation	,97979587
Most Extreme Differences	Absolute	,115
	Positive	,115
	Negative	-,086
Kolmogorov-Smirnov Z		1,002
Asymp. Sig. (2-tailed)		,268

a. Test distribution is Normal.

b. Calculated from data.

Source: Appendix 10

The result of Kolmogorov-Smirnov test above shows that the significant value is 0.268 for exchange rate. To passed the normality test, the result of Kolmogorov-Smirnov test should be bigger than 0.05. Since the significant value is bigger than the real value which is 0.05, it can be inferred that the distribution of the data in the research is normal.

## **E. Inferential Statistical Analysis**

### **1. Multiple Linear Regressions Analysis**

The multiple linear regression analysis is used to analyze whether or not independent variable has an influence towards the dependent variable. In this research, the independent variables are net exports, economic growth and inflation meanwhile the dependent variable are exchange rate. So, the multiple

linear regression analysis will answer whether or not net exports, economic growth and inflation will influence exchange rates.

The research will be using China's and United States' data. Based on the multiple linear regression model, researcher can get the output of the analysis with the help of SPSS 23.0. The output of the analysis will be shown in table 14.

**Table 14. Regression Coefficients of Exchange Rate**

Coefficients <sup>a</sup>						
Model		Unstandardized Coefficients		Standardized Coefficients	t	Sig.
		B	Std. Error	Beta		
1	(Constant)	2,425	,702		3,452	,001
	Net Export (X1)	,0003	,000	,223	2,143	,036
	GDP (X2)	-,222	,071	-,329	-3,149	,002
	CPI (X3)	-2,215	,801	-,292	-2,764	,007

a. Dependent Variable: Rate (Y)

Source: Appendix 8

Based on table X, it can be concluded that the regression equation for exchange rates:

$$Y = 2,425 + 0,0003X_1 - 0,222X_2 - 2,215X_3 + e$$

The equation above will be explained as follows:

- The value of the constant is 2,425. It means if the net exports, economic growth and inflation valued as 0, the exchange rates value will be 2,425.
- Regression coefficient of net exports variable is 0,0003. Under ceteris paribus assumption, if the net exports increase for one unit, then the exchange rates will increase by 0,0003 unit.

- c. Regression coefficient of economic growth is  $-0,222$ . Since the coefficient is negative, there will be negative influence between economic growth and exchange rates. The economic growth will go in the opposite direction with exchange rates. Under *ceteris paribus* assumption, if the economic growth increase for one unit, then the exchange rates will be decreased by  $0,222$  unit.
- d. Regression coefficient of inflation is  $-2,215$ . Since the coefficient is negative, there will be negative influence between inflation and exchange rates. The inflation will go in the opposite direction with exchange rates. Under *ceteris paribus* assumption, if the inflation increases for one unit, then the exchange rates will be decreased by  $2,215$  unit.

## 2. Simultaneous Test (F Test)

Simultaneous test or the f test has a purpose to identify whether the independent variables have a significant influence on dependent variable simultaneously or not (Sanusi, 2014:137). The result of the F test will be stated in the ANOVA Result from SPSS 23. The result will be shown in table 15 below.

**Table 15. ANOVA Result of Exchange Rates**

**ANOVA<sup>a</sup>**

Model		Sum of Squares	df	Mean Square	F	Sig.
1	Regression	487,892	3	162,631	7,386	,000 <sup>a</sup>
	Residual	1585,256	72	22,017		
	Total	2073,148	75			

Source: Appendix 8



The hypothesis of this research said that China's and United States' net exports (X1), economic growth (X2) and inflation (X3) has a significant influence simultaneously towards Indonesian rupiah exchange rates (Y). The result of the F test in table 15 shows that F statistic is 7,386 and the F table is 3,12. It is shown that the F statistic is bigger than the F table.

The significant value itself are 0,000 which is less than the real value 0,05. Based on those F test result, it can be concluded that  $H_0$  is rejected and  $H_1$  is accepted. The conclusion of the result from the hypothesis taken inferred that net exports (X1), economic growth (X2) and inflation (X3) of China and United States simultaneously influencing exchange rates (Y).

### 3. Partial Test (t test)

#### a. Net Exports (X1)

The hypothesis of this research said that China's and United States' net exports (X1) has a significant influence partially towards Indonesian rupiah exchange rates (Y). In table 14 at page 81, it is shown that the value of t statistic is  $| 2,143 |$  for net exports variable. The value flanked by two vertical lines shows that the value is absolute, where positive or negative sign is ignored.

The value of the t table is 1,993, which can be inferred that the t statistic is bigger than t table. Meanwhile the significant value of net exports is 0,036, which is smaller than 0,05. Those comparison is showing that  $H_0$  rejected and

$H_1$  accepted. It can be concluded that net exports partially have significant influence towards exchange rates.

b. Economic Growth (X2)

The hypothesis of this research said that China's and United States' economic growth (X2) has significant influence partially towards Indonesian rupiah exchange rates (Y). In table 14 at page 81, it is shown that the value of t statistic is  $|-3,149|$  for economic growth variable. The value flanked by two vertical lines shows that the value is absolute, where positive or negative sign is ignored.

The value of the t table is 1,993, which can be inferred that the t statistic is bigger than t table. Meanwhile the significant value of economic growth is 0,002, which is smaller than 0,05. Those comparison is showing that  $H_0$  rejected and  $H_1$  accepted. It can be concluded that economic growth partially has significant influence towards exchange rates.

c. Inflation (X3)

The hypothesis of this research said that China's and United States' inflation (X3) has a significant influence partially towards Indonesian rupiah exchange rates (Y). In table 14 at page 81, it is shown that the value of t statistic is  $|-2,764|$  for inflation variable. The value flanked by two vertical lines shows that the value is absolute, where positive or negative sign is ignored.

The value of the t table is 1,993, which can be inferred that the t statistic is bigger than t table. Meanwhile the significant value of inflation is 0,007, which is smaller than 0,05. Those comparison is showing that  $H_0$  rejected and  $H_1$  accepted. It can be concluded that inflation partially have significant influence towards exchange rates.

#### 4. Coefficient Determination Analysis

The coefficient of determination or  $R^2$  aims to measure the ability of the model in explaining variations in the dependent variable with a value between zero and one. According to Sanusi (2014:136), the multiple linear regression equation is getting better when the coefficient is getting closer to one. The coefficient of determination is carried out to determine the percentage effect of independent variables namely net exports, economic growth and inflation on the dependent variable, namely exchange rates. Through the help of SPSS 23.0 the following results are:

**Table 16. Model Summary of Exchange Rates**

##### Model Summary

Model	R	R Square	Adjusted R Square	Std. Error of the Estimate
1	,485 <sup>a</sup>	,235	,203	4,692275

a. Predictors: (Constant), CPI (X3), Net Export (X1), GDP (X2)

Source: Appendix 8

Table 16 is the model summary that shows variance in the exchange rates variable. Adjusted R Square shows the value of 0.203, which explains that the net exports, economic growth and inflation is influencing the exchange rates variable by 20,3%. As for the rest 79,7% are influenced by other variable that is not included in this research such as interest rate, money supply and etc.

## **F. Discussion**

### **1. Influence of Net Exports (X1) towards Exchange Rates (Y)**

According to the statistical result of the research, it is discovered that net exports variable has a partial significant influence towards exchange rates. The hypothesis which states that there is a partial significant influence between net exports and exchange rates is accepted. Based on the Trade Approach or Elasticity to Exchange Rate Determination (Ekananda, 2014:225), it is explained that the difference in exchange rates between the two countries is influenced by the volume of trade between the countries related. The result shows positive influence between net exports and exchange rates.

This result shared the same result with research that is conducted by Muzzaky (2015) and Dion, *et al* (2005) that showed export and import has significant influence towards exchange rate. It is also the same with Sedyaningrum (2016) but different direction, one showed positive influence yet the other showed negative influence. Sedyaningrum's research showed that export has negative significant influence towards exchange rate, and no significant influence from

import towards exchange rate. The contradictory result might happen because Sedyaningrum's variable are the macroeconomics data in Indonesia only, meanwhile this research is figuring the macroeconomics data from China and United States. But the result is still based on the Trade approach theory.

When a country has a greater imports value than exports or has a trade balance deficit, the exchange rate will weaken and vice versa. According to Trade Approach theory if China and United States experiencing trade deficit, the domestic currency will depreciate. Those countries will do it to make domestic price cheaper so that export value will increase and import value decrease. It is needed to regained each country's trade balance. When it happens, United States dollar will depreciate and will affect the increase value of Indonesian rupiah rate.

## **2. Influence of Economic Growth (X2) towards Exchange Rates (Y)**

According to the statistical result of the research, it is discovered that economic growth variable that is measured using GDP has a partial significant influence towards exchange rates. Based on the t test result, the hypothesis which states that there is a partial significant influence between economic growth and exchange rates is accepted. It is also shown that economic growth has negative influence towards exchange rate. This result is contradictory with the research result that is conducted by Rusdiana (2011), Puspitaningrum (2013) and Sedyaningrum (2016). The result in all three previous research are stating that there is no significant influence between economic growth and exchange rates.

According to Sukirno (2010:402), if economic growth value rises it will infer that the productivity and exports volume also rises. Those condition will make the demand of domestic currency increased and the exchange rate strengthened, this is in accordance to Trade Approach theory. If China's and United States' GDP increased, it means that both countries domestic exchange rate strengthened. When United States dollar strengthened, it means that the currency of exchange rate will experience depreciation. The results of this t test indicate that there is a difference with Sukirno's statement that has been mentioned before.

### **3. Influence of Inflation (X3) towards Exchange Rates (Y)**

According to the statistical result of the research, it is discovered that inflation variable that is measured using CPI has a partial significant influence towards exchange rates. Based on the t test result, the hypothesis which states that there is a partial significant influence between inflation and exchange rates is accepted. Based on the PPP theory, inflation that is increasing will cause the people of the country to consume imported goods. If the inflation in China and United States are rising, both countries tended to consume imported goods because domestic prices are rising.

Since Indonesia is one of China's and United States' trading partner, it can be assumed that Indonesia's export volume increases due to the inflation that China and United States' experiencing. When it happens, the rupiah exchange rate is strengthening and it is in accordance to the result of the research that inflation has a negative influence towards Indonesian rupiah exchange rate. This result is in

accordance with the research result that is conducted by Rusdiana (2011), Widiastuti (2011), Puspitaningrum (2013), Muzzaky (2015) and Venkatesan, *et al* (2017). The result in all previous research are stating that there is significant influence between inflation and exchange rates.

#### **4. Influence of Net Exports (X1), Economic Growth (X2), and Inflation (X3) towards Exchange Rates**

According to the statistical result of the research, it is shown that net exports, economic growth and inflation variables simultaneously have significant influence towards exchange rates. The hypothesis that stated net exports, economic growth and inflation variables simultaneously have significant influence towards exchange rates are accepted. This result is in accordance with the research result that is conducted by Sedyaningrum (2016) though it does not explain about the inflation. The results showed that net exports, economic growth and inflation is one of the determinants of exchange rates between Indonesian rupiah and United States dollar. It is also in accordance with the result of Dion, *et al* (2005), that stated exports and imports simultaneously influence exchange rate of Canadian dollar.

Based on the Trade Approach theory or Elasticity to Exchange Rate Determination (Ekananda, 2014:225), the trading volume between countries will influence the exchange rate of the nation's currency. The exchange rate also influenced the pattern of a country's economy. When a country's economy is in a

condition where the imports are higher than exports, trade deficit will happen and will weakens the value of the exchange rate.

Meanwhile based on the PPP theory, inflation that is increasing will cause the people of the country to consume imported goods. Same as Trade Approach theory, when a country experience hinger imports, trade deficit happens will weakens the value of the exchange rate. So, both of the theory supports the current hypothesis that is proven in the result, which net exports, economic growth and inflation of China and United States simultaneously have significant influence towards exchange rates.

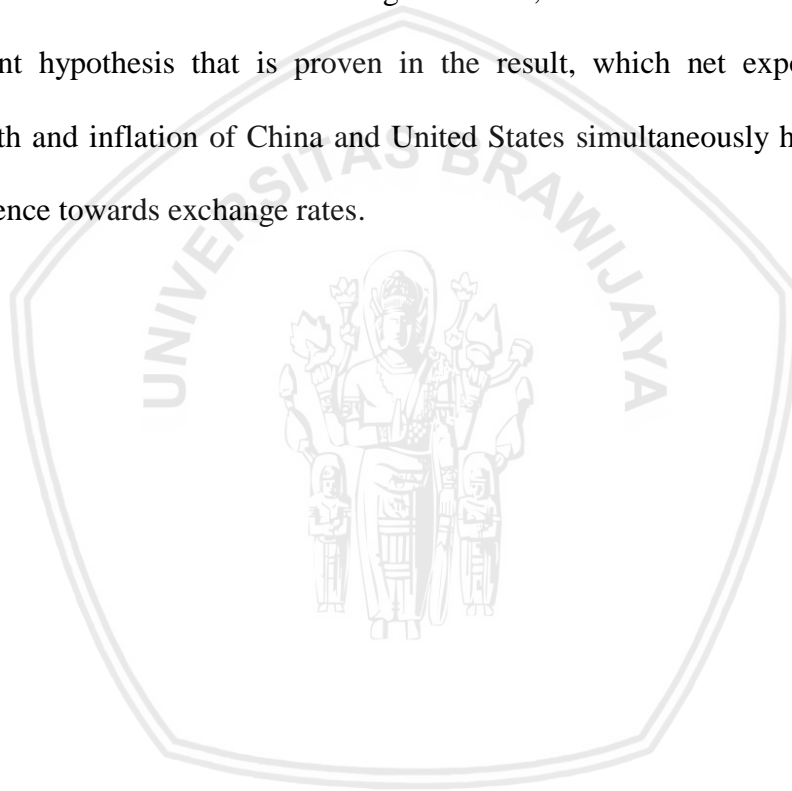



## CHAPTER V

### CONCLUSION AND RECOMMENDATION

#### A. Conclusion

This research is conducted to analyze the influence of China's and the United States' macroeconomic variables on rupiah exchange rate. Based on the result of the research by using multiple linear regression analysis, then obtained the following conclusions:

1. Based on the t test, net exports of China and United States have a significant influence towards rupiah exchange rate. The result is contradictory with the research that was conducted by Sedyaningrum (2016). The result also shows that net exports have a positive influence. According to Trade Approach theory, if China and United States experiencing trade deficit, the domestic currency will depreciate. Those countries will do it to make domestic price cheaper so that export value will increase and import value decrease. It is needed to regained each country's trade balance. When it happens, United States dollar will depreciate and will affect the increase value of Indonesian rupiah rate.
2. Based on the t test, economic growth of China and United States have a significant influence towards rupiah exchange rate. This result is contradictory with the research result that is conducted by Rusdiana (2011), Puspitaningrum (2013) and Sedyaningrum (2016). The result shows that there is a negative

influence between economic growth and exchange rate and shows the opposite result of the theory mentioned by Sukirno. If economic growth value rises, it will infer that the productivity and exports volume also rise. If China's and United States' economic growth increased, it means that both countries domestic exchange rate strengthened. When United States dollar strengthened, it means that the currency of exchange rate will experience depreciation.

3. Based on the t test, Inflation has a significant influence towards rupiah exchange rate and in accordance with the research result that was conducted by Rusdiana (2011), Widiastuti (2011), Puspitaningrum (2013), Muzzaky (2015) and Venkatesan, *et al* (2017). The influence between inflation and exchange rate is a negative influence. Based on the PPP theory, inflation that is increasing will cause the people of the country to consume imported goods. Because Indonesia is one of China's and United States' trading partner, it can be assumed that Indonesia's export volume increase. When inflation in China and United States rises, the rupiah exchange rate is strengthening and it is in accordance to the result of the research that inflation has a negative influence towards Indonesian rupiah exchange rate.
4. Based on the F test, net exports, economic growth and inflation variables simultaneously have significant influence towards exchange rates. This result is in accordance with the result of research that is conducted by Sedyaningrum (2016) though it doesn't explain about the inflation. Net export, economic growth and inflation is one of the factors that influence the value of rupiah exchange rate.

## B. Recommendation

The researcher is aware that this research combines the variables of two countries which is China and United States into one, then sees the influence between two countries directly towards Indonesian rupiah exchange rate. The result of this research is expected to contribute practically to company or government. The following recommendations can be realized by the company or government as well as further research:

1. Economic actors that is engaged in international trading, is expected to know when to increase or decrease the volume of exports and imports of the country. Also applies for the government to make policies related in response to changes that is happening in exchange rates. The increase volume of export and imports is expected to have an effect on the rupiah exchange rate that can strengthen, given that the results of Astiyah, *et al* (2005) state that the exchange rate has an effect on export-import activities.
2. Exporters and importers are expected to pay attention to various developments in information regarding net export value, economic growth and inflation given that these three variables have a significant influence on the exchange rate of the rupiah towards the United States dollar. By knowing this information, exporters and importers can determine the trading activities that must be carried out considering that the trade carried out is financed using US dollars.

3. The independent variables that is included in this research are important factors that influence the rupiah exchange rate, so it is hoped that this research can be developed through further research by developing other independent variables which are not included in this research. In addition, it is better if in further research the variables of China and United States can be separated to see which ones have more influence towards Indonesian rupiah exchange rate. It is also good to see whether or not the variables influencing other exchange rate, because this research only focuses on Indonesian rupiah and United States dollar.

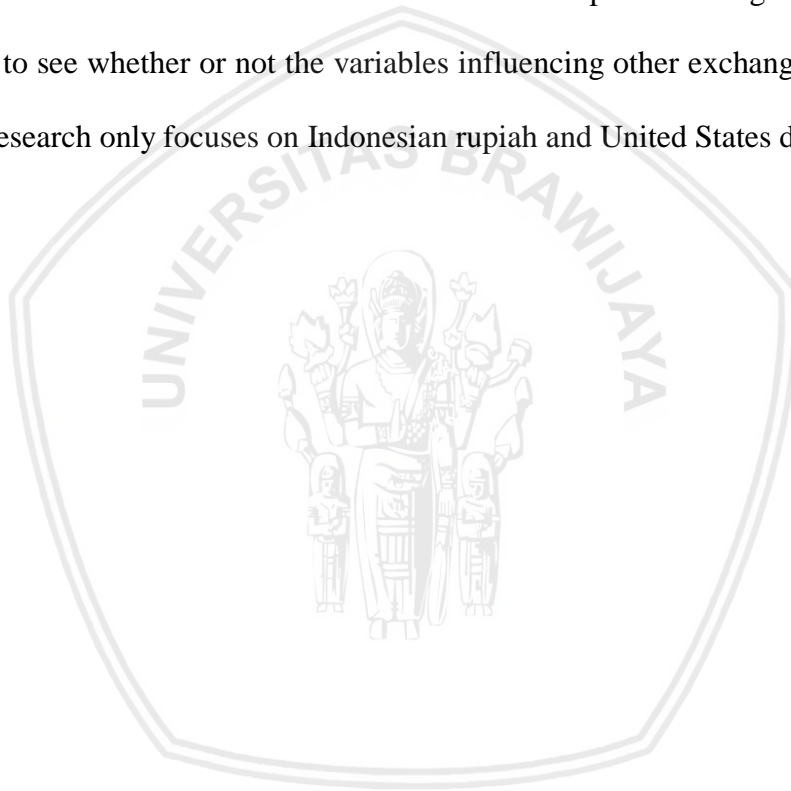

## REFERENCES

### Books:

- Algifari. 2009. *Analisis Statistik untuk Bisnis dengan Regresi, Korelasi, dan Nonparametrik*. First edition. Yogyakarta:BPFE
- Boediono. 2006. *Teori Pertumbuhan Ekonomi*. Yogyakarta: BPFE
- Brigham, Eugene F and Houston. 2006. *Dasar-dasar Manajemen Keuangan*. Jakarta: Salemba Empat
- Creswell, John W. 2016. *Research Design: Pendekatan Metode Kualitatif, Kuantitatif, dan Campuran Edisi Keempat*. Yogyakarta: Pustaka Pelajar
- Ekananda, Mahyus. 2014. *Ekonomi Internasional*. Jakarta: Erlangga
- Ghozali, I. 2006. *Aplikasi Analisis Multivariate dengan Program IBM SPSS 19*. Edisi kelima. Semarang: Badan Penerbit Universitas Diponegoro
- Madura, Jeff. 2000. *International Financial Management*. 6th Edition. Boston: South-Western College Publishing
- Mankiw, N.Gregory. Quah, Euston and Wilson, Peter. 2014. *Pengantar ekonomi makro*. Jakarta: Salemba Empat
- Mankiw, N. Gregory. 2012. *Principles of Macroeconomics*. Canada: South-Western Cengage Learning.
- Mankiw, N. Gregory. 2010. *Macroeconomics: 7<sup>th</sup> Edition*. United States of America: Worth Publishers
- Manurung, Mandala & Rahardja. 2008. *Teori Ekonomi Makro Suatu Pengantar*. Jakarta: Lembaga Penerbit Fakultas Ekonomi Universitas Indonesia.
- Martono, Nanang. 2010. *Metode penelitian kuantitatif: Analisis Isi dan Analisis Data Sekunder*. Jakarta. PT Raja Grafindo Persada.
- Miles, David. Scott, Andrew and Breedon, Francis. 2012. *Macroeconomics: Understanding The Global Economy*. United Kingdom: John Wiley & Sons. Ltd

- Misbahuddin dan Hasan, Iqbal. 2013. *Analisis Data Penelitian dengan Statistik*. Jakarta: Bumi Aksara
- Murni, Asfia. 2006. *Ekonomika Makro*. Bandung: PT. Refika Aditama
- \_\_\_\_\_. 2009. *Ekonomika Makro*. Bandung: PT Refika Aditama
- Nanga, Muana. 2005. *Makro Ekonomi: Teori, Masalah dan Kebijakan*. Jakarta: PT Grafindo Persada
- Noor, Juliansyah. 2011. *Metodologi Penelitian: Skripsi, Tesis, Disertasi dan Karya Ilmiah*. First Edition. Jakarta: Prenadamedia Group
- Putong, Iskandar. 2013. *Economics Pengantar Mikro dan Makro*. Fifth Edition. Jakarta: Mitra Wacana Media
- Salvatore, D. 2009. *International Economic: Trade and Finance*. Tenth Edition. Singapore: John Willey and Sons.
- Salvatore, D. 2014. *Ekonomi Internasional*. Ninth Edition. Jakarta: Salemba Empat
- Sanusi, Anwar. 2014. *Metodologi Penelitian Bisnis*. Jakarta: Salemba Empat
- Siregar, Syofian. 2016. *Statistika Deskriptif untuk Penelitian*. Jakarta: Rajawali Press
- Sudarmanto, R. Gunawan. 2013. *Statistik Terapan Berbasis Komputer Dengan Program IBM SPSS 19*. Jakarta: Mitra Wacana Media
- Sunariyah. 2006. *Pengantar Pengetahuan Pasar Modal Edisi ke Lima*. Yogyakarta: UPP STIM YKPN
- Sugiyono. 2009. *Metode Penelitian Bisnis*. Bandung: Alfabeta
- \_\_\_\_\_. 2012. *Metode Penelitian Kuantitatif, Kualitatif dan R&D*. Bandung: Alfabeta.
- \_\_\_\_\_. 2013. *Metode Penelitian Bisnis (Kuantitatif, Kualitatif dan R&D)*. Bandung: Alfabeta.
- \_\_\_\_\_. 2017. *Metode Penelitian Pendidikan Pendekatan Kuantitatif, Kualitatif dan R&D*. Bandung: Alfabeta.

Sukirno, Sadono. 2010. *Makroekonomi Teori Pengantar Edisi Ketiga*. Jakarta: PT Raja Grafindo Persada.

Supranto, J. 2016. *Statistik Teori & Aplikasi Edisi Kedepalan*. Jakarta: Erlangga

### **Journals and Thesis:**

Astiyah, Siti. Santoso, M. Setyawan. 2005. Nilai Tukar dan Trade Flows. *The Bulletin of Monetary Economics and Banking*, Vol. 8 No.3, 1-32

Dion, *et al.* 2005. Exports, Imports and the Appreciation of Canadian Dollar. *Bank of Canada Review*, Autumn Review

Muzzaky, A. 2015. Pengaruh Inflasi, Tingkat Suku Bunga SBI, Pendapatan Perkapita, dan Ekspor terhadap Nilai Tukar Rupiah dan Pertumbuhan Ekonomi. *Skripsi Fakultas Ilmu Administrasi Universitas Brawijaya*. Not published.

Sedyaningrum, Miranti. 2016. Pengaruh Jumlah Nilai Ekspor, Impor dan Pertumbuhan Ekonomi terhadap Nilai Tukar dan Daya Beli Masyarakat di Indonesia. *Skripsi Fakultas Ilmu Administrasi Universitas Brawijaya*. Not Published.

Puspitaningrum, Roshinta. 2013. Pengaruh Tingkat Inflasi, Tingkat Suku Bunga SBI, dan Pertumbuhan Ekonomi Terhadap Nilai Tukar Rupiah. *Skripsi Fakultas Ilmu Administrasi Universitas Brawijaya Malang*. Not published.

Rusdiana, Kunthi. 2011. Analisis Pengaruh Inflasi, Suku Bunga Bank Indonesia, Produk Domestik Bruto, Net Ekspor, dan Cadangan Devisa Indonesia Terhadap Nilai Tukar. *Skripsi Fakultas Ekonomi Universitas Brawijaya Malang*. Not published.

Suselo, *et al.* 2008. Pengaruh Volatilitas Nilai Tukar terhadap Pertumbuhan Ekonomi Indonesia. *The Bulletin of Monetary Economics and Banking*, Vol. 10 No.3, 181-220

Venkatesan, *et al.* 2017. An Analysis of Macroeconomic Factors Affecting Foreign Exchange Rate. *SDMIMD Journal of Management*, Vol. 8, 21-29.

Widiastuti, Yeni Permana. 2011. Analisis Pengaruh Jumlah Uang Beredar, Suku Bunga Indonesia dan Inflasi (IHK) terhadap Nilai Tukar Rupiah Tahun 2000-2009. *Skripsi Fakultas Ekonomi Universitas Brawijaya Malang*. Not published

#### Internet:

Board of Governors of the Federal Reserve System. 2017. *Is the Federal Reserve accountable to anyone*. accessed on 11<sup>th</sup> February 2019 from [https://www.federalreserve.gov/faqs/about\\_12798.htm](https://www.federalreserve.gov/faqs/about_12798.htm)

CIA. 2017. *The World Factbook*. accessed on 25<sup>th</sup> November 2018 from <https://www.cia.gov/library/publications/the-world-factbook/rankorder/2078rank.html>

\_\_\_\_\_. 2019. *The World Factbook*. accessed on 22<sup>nd</sup> April 2019 from <https://www.cia.gov/library/publications/the-world-factbook/geos/id.html>

Economic Research Federal Reserve Bank of St. Louis. 2018. *FRED Economic Data*. accessed on 11<sup>th</sup> February 2019 from <https://fred.stlouisfed.org/>

Focus Economics. 2018. *The World's Top 10 Largest Economies*. accessed on 26<sup>th</sup> November 2018 from <https://www.focus-economics.com/blog/the-largest-economies-in-the-world>

International Monetary Fund. 2018. *Gross Domestic Product*. accessed on 26<sup>th</sup> November 2018 from <http://data.imf.org/regular.aspx?key=61545864>

\_\_\_\_\_. 2019. *Factsheet*. accessed on 26<sup>th</sup> March 2019 from <https://www.imf.org/en/About/Factsheets/>

Kompas.com. 2018. *Perang Dagang Terus Berlanjut, Bagaimana Dampaknya ke Indonesia?*. accessed 12<sup>th</sup> February 2019 from <https://ekonomi.kompas.com/read/2018/08/30/224900826/perang-dagang-terus-berlanjut-bagaimana-dampaknya-ke-indonesia->

Liputan6. 2018. *Dolar AS Perkasa Bikin Rupiah Tembus 15.179*. accessed 12<sup>th</sup> February 2019 from <https://www.liputan6.com/bisnis/read/3659443/dolar-as-perkasa-bikin-rupiah-tembus-15179>



New York Times. 2018. *Just the Fear of a Trade War Is Straining the Global Economy*. accessed 28<sup>th</sup> November 2018 from <https://www.nytimes.com/2018/06/16/business/tariffs-trade-war.html>.

OECD. 2018. *Exchange rates (indicator)*. accessed on 22 December 2018 from doi: 10.1787/037ed317-en



## Appendix 1. Net Exports Value of China

Year	Quarter	Net Export (X1)	Ratio
2009	I	62,247.00	-92.04
	II	33,898.00	-45.54
	III	38,326.00	13.06
	IV	61,153.00	59.56
2010	I	13,889.00	-77.29
	II	41,045.00	195.52
	III	64,863.00	58.03
	IV	61,708.00	-4.86
2011	I	-2,281.00	-103.70
	II	46,344.00	-2,131.74
	III	62,577.00	35.03
	IV	48,258.00	-22.88
2012	I	194.00	-99.60
	II	68,390.00	35,152.58
	III	79,184.00	15.78
	IV	83,321.71	5.23
2013	I	43,548.63	-47.73
	II	65,710.85	50.89
	III	61,553.93	-6.33
	IV	90,548.48	47.10
2014	I	16,583.80	-81.69
	II	85,939.00	418.21
	III	128,100.38	49.06
	IV	149,493.74	16.70
2015	I	123,732.10	-17.23
	II	139,540.68	12.78
	III	163,606.55	17.25
	IV	174,777.36	6.83
2016	I	125,736.25	-28.06
	II	143,441.99	14.08
	III	144,254.30	0.57
	IV	133,812.42	-7.24
2017	I	66,111.90	-50.59
	II	121,579.12	83.90
	III	117,249.59	-3.56
	IV	133,083.81	13.50
2018	I	49,117.95	-63.09
	II	94,773.55	92.95

## Appendix 2. Net Exports Value of United States

Year	Quarter	Net Export (X1)	Ratio
2009	I	-118,526.80	-37.69
	II	-122,013.53	2.94
	III	-154,603.73	26.71
	IV	-154,108.67	-0.32
2010	I	-143,380.97	-6.96
	II	-176,645.34	23.20
	III	-199,051.27	12.68
	IV	-172,311.82	-13.43
2011	I	-171,704.69	-0.35
	II	-200,307.67	16.66
	III	-214,133.48	6.90
	IV	-197,370.39	-7.83
2012	I	-185,290.30	-6.12
	II	-203,791.37	9.98
	III	-210,687.55	3.38
	IV	-190,895.20	-9.39
2013	I	-168,801.63	-11.57
	II	-190,559.47	12.89
	III	-209,442.91	9.91
	IV	-181,186.57	-13.49
2014	I	-174,458.27	-3.71
	II	-206,078.62	18.12
	III	-218,059.64	5.81
	IV	-200,859.84	-7.89
2015	I	-186,448.46	-7.17
	II	-203,360.91	9.07
	III	-220,443.34	8.40
	IV	-202,308.16	-8.23
2016	I	-181,006.06	-10.53
	II	-198,277.48	9.54
	III	-214,696.51	8.28
	IV	-204,940.29	-4.54
2017	I	-192,715.06	-5.97
	II	-217,471.47	12.85
	III	-223,981.39	2.99
	IV	-228,034.82	1.81
2018	I	-213,426.69	-6.41
	II	-224,998.14	5.42

## Appendix 3. GDP of China

Year	Quarter	GDP (X2)	Ratio
2009	I	7,397,920.00	-16.60
	II	8,386,580.00	13.36
	III	8,984,690.00	7.13
	IV	10,082,580.00	12.22
2010	I	8,750,130.00	-13.22
	II	9,934,740.00	13.54
	III	10,596,370.00	6.66
	IV	11,930,680.00	12.59
2011	I	10,446,990.00	-12.44
	II	11,889,590.00	13.81
	III	12,656,220.00	6.45
	IV	13,801,210.00	9.05
2012	I	11,735,760.00	-14.97
	II	13,132,060.00	11.90
	III	13,808,960.00	5.15
	IV	15,181,200.00	9.94
2013	I	12,944,960.00	-14.73
	II	14,351,870.00	10.87
	III	15,222,270.00	6.06
	IV	16,777,230.00	10.22
2014	I	14,027,020.00	-16.39
	II	15,592,230.00	11.16
	III	16,489,780.00	5.76
	IV	18,019,030.00	9.27
2015	I	15,059,380.00	-16.43
	II	16,787,450.00	11.48
	III	17,580,380.00	4.72
	IV	19,172,080.00	9.05
2016	I	16,096,730.00	-16.04
	II	17,987,870.00	11.75
	III	18,933,760.00	5.26
	IV	20,987,720.00	10.85
2017	I	17,940,340.00	-14.52
	II	19,917,780.00	11.02
	III	20,982,410.00	5.35
	IV	23,234,900.00	10.74
2018	I	19,792,000.00	-14.82
	II	21,929,540.00	10.80

## Appendix 4. GDP of United States

Year	Quarter	GDP (X2)	Ratio
2009	I	3,598,636.75	-1.13
	II	3,588,212.50	-0.29
	III	3,605,078.00	0.47
	IV	3,657,005.25	1.44
2010	I	3,680,337.50	0.64
	II	3,731,524.50	1.39
	III	3,769,979.25	1.03
	IV	3,810,210.75	1.07
2011	I	3,821,457.00	0.30
	II	3,874,047.25	1.38
	III	3,897,962.50	0.62
	IV	3,949,115.00	1.31
2012	I	4,004,939.50	1.41
	II	4,038,064.25	0.83
	III	4,064,287.75	0.65
	IV	4,089,715.75	0.63
2013	I	4,142,397.75	1.29
	II	4,159,481.50	0.41
	III	4,212,187.00	1.27
	IV	4,270,784.25	1.39
2014	I	4,275,733.00	0.12
	II	4,356,441.50	1.89
	III	4,429,959.00	1.69
	IV	4,459,613.50	0.67
2015	I	4,492,605.50	0.74
	II	4,555,324.75	1.40
	III	4,582,773.25	0.60
	IV	4,588,593.00	0.13
2016	I	4,602,282.50	0.30
	II	4,660,183.00	1.26
	III	4,699,912.00	0.85
	IV	4,744,811.25	0.96
2017	I	4,790,637.50	0.97
	II	4,839,780.75	1.03
	III	4,897,018.50	1.18
	IV	4,957,957.25	1.24
2018	I	5,010,261.75	1.05
	II	5,102,981.00	1.85

## Appendix 5. CPI of China

Year	Quarter	CPI (X3)	Ratio
2009	I	97.25	0.39
	II	96.51	-0.76
	III	96.54	0.03
	IV	97.38	0.87
2010	I	99.27	1.94
	II	99.13	-0.14
	III	99.69	0.56
	IV	101.9	2.22
2011	I	104.45	2.50
	II	105.04	0.56
	III	106.11	1.02
	IV	106.61	0.47
2012	I	108.35	1.63
	II	107.95	-0.37
	III	108.13	0.17
	IV	108.85	0.67
2013	I	111.02	1.99
	II	110.53	-0.44
	III	111.08	0.50
	IV	112.01	0.84
2014	I	113.5	1.33
	II	112.89	-0.54
	III	113.2	0.27
	IV	113.58	0.34
2015	I	114.81	1.08
	II	114.42	-0.34
	III	115.23	0.71
	IV	115.23	0.00
2016	I	117.22	1.73
	II	116.84	-0.32
	III	117.11	0.23
	IV	117.72	0.52
2017	I	118.91	1.01
	II	118.6	-0.26
	III	118.98	0.32
	IV	119.86	0.74
2018	I	121.43	1.31
	II	120.63	-0.66

## Appendix 6. CPI of United States

Year	Quarter	CPI (X3)	Ratio
2009	I	97.23	-0.50
	II	98.26	1.06
	III	98.93	0.68
	IV	99.13	0.20
2010	I	99.52	0.39
	II	100	0.48
	III	100.09	0.09
	IV	100.39	0.30
2011	I	101.66	1.27
	II	103.43	1.74
	III	103.85	0.41
	IV	103.69	-0.15
2012	I	104.52	0.80
	II	105.38	0.82
	III	105.61	0.22
	IV	105.65	0.04
2013	I	106.28	0.60
	II	106.85	0.54
	III	107.25	0.37
	IV	106.96	-0.27
2014	I	107.77	0.76
	II	109.04	1.18
	III	109.17	0.12
	IV	108.29	-0.81
2015	I	107.7	-0.54
	II	109	1.21
	III	109.29	0.27
	IV	108.79	-0.46
2016	I	108.87	0.07
	II	110.14	1.17
	III	110.51	0.34
	IV	110.75	0.22
2017	I	111.63	0.79
	II	112.24	0.55
	III	112.68	0.39
	IV	113.1	0.37
2018	I	114.1	0.88
	II	115.28	1.03

## Appendix 7. Exchange Rate of IDR-USD

Year	Quarter	Rate (Y)	Ratio
2009	I	11,575.00	5.71
	II	10,225.00	-11.66
	III	9,681.00	-5.32
	IV	9,400.00	-2.90
2010	I	9,115.00	-3.03
	II	9,083.00	-0.35
	III	8,924.00	-1.75
	IV	8,991.00	0.75
2011	I	8,709.00	-3.14
	II	8,597.00	-1.29
	III	8,823.00	2.63
	IV	9,068.00	2.78
2012	I	9,180.00	1.24
	II	9,480.00	3.27
	III	9,588.00	1.14
	IV	9,670.00	0.86
2013	I	9,719.00	0.51
	II	9,929.00	2.16
	III	11,613.00	16.96
	IV	12,189.00	4.96
2014	I	11,404.00	-6.44
	II	11,969.00	4.95
	III	12,212.00	2.03
	IV	12,440.00	1.87
2015	I	13,084.00	5.18
	II	13,332.00	1.90
	III	14,657.00	9.94
	IV	13,795.00	-5.88
2016	I	13,276.00	-3.76
	II	13,180.00	-0.72
	III	12,998.00	-1.38
	IV	13,436.00	3.37
2017	I	13,321.00	-0.86
	II	13,319.00	-0.02
	III	13,492.00	1.30
	IV	13,548.00	0.42
2018	I	13,756.00	1.54
	II	14,404.00	4.71



## Appendix 8. SPSS 23.0 Result

**Coefficients<sup>a</sup>**

Model		Collinearity Statistics	
		Tolerance	VIF
1	Net Export (X1)	,929	1,077
	GDP (X2)	,943	1,060
	CPI (X3)	,983	1,017

a. Dependent Variable: Rate (Y)

**Model Summary<sup>b</sup>**

Model	Durbin-Watson
1	1,954 <sup>a</sup>

a. Predictors: (Constant), CPI (X3), GDP (X2), Net Export (X1)

b. Dependent Variable: Rate (Y)

**Model Summary**

Model	R	R Square	Adjusted R Square	Std. Error of the Estimate
1	,485 <sup>a</sup>	,235	,203	4,692275

a. Predictors: (Constant), CPI (X3), Net Export (X1), GDP (X2)

**ANOVA<sup>b</sup>**

Model		Sum of Squares	df	Mean Square	F	Sig.
1	Regression	487,892	3	162,631	7,386	,000 <sup>a</sup>
	Residual	1585,256	72	22,017		
	Total	2073,148	75			

a. Predictors: (Constant), CPI (X3), Net Export (X1), GDP (X2)

b. Dependent Variable: Rate (Y)

**Coefficients<sup>a</sup>**

Model		Unstandardized Coefficients		Standardized Coefficients	t	Sig.
		B	Std. Error	Beta		
1	(Constant)	2,425	,702		3,452	,001
	Net Export (X1)	,0003	,000	,223	2,143	,036
	GDP (X2)	-,222	,071	-,329	-3,149	,002
	CPI (X3)	-2,215	,801	-,292	-2,764	,007

a. Dependent Variable: Rate (Y)

## Appendix 9. Scatterplot Graphic

## Scatterplot

Dependent Variable: Rate (Y)

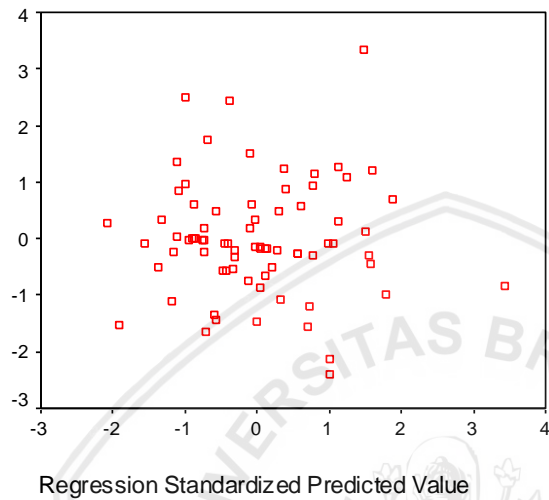

## Appendix 10. Kolmogorov-Smirnov Test

## One-Sample Kolmogorov-Smirnov Test

		Standardized Residual
N		76
Normal Parameters <sup>a,b</sup>	Mean	,0000000
	Std. Deviation	,97979587
Most Extreme Differences	Absolute	,115
	Positive	,115
	Negative	-,086
Kolmogorov-Smirnov Z		1,002
Asymp. Sig. (2-tailed)		,268

a. Test distribution is Normal.

b. Calculated from data.

## Appendix 11. Curriculum Vitae

**Curriculum Vitae**

**Name** : Adinda Bani Megawati  
**NIM** : 155030200111081  
**Religion** : Islam  
**Date of Birth** : 19 June 1997  
**Address** : Jl. Papa Hijau Number 3  
**Phone** : 081217603608  
**Email** : adindabanim@gmail.com

**Educational Background:**

1. Fakultas Ilmu Administrasi, Universitas Brawijaya Malang (2015-2019)
2. SMA Negeri 1 Bogor (2011-2014)
3. SMP Negeri 1 Bogor (2008-2011)
4. SD Madania (2008-2002)

**Experiences:**

1. Finance Department Intern in Halliburton Indonesia (2018)
2. Active member of AIESEC in Universitas Brawijaya (2016-2018)
3. Event Staff ADFEST 2.0 (2017)
4. Event Staff ESPRIEX BMC ASEAN (2017)
5. Event Staff October Project (2016)
6. Event Staff Young on Top Jakarta (2015)