

## LAMPIRAN

### LAMPIRAN 1 : Foto Alat

**Gambar 1.** Foto Alat dan Keterangan

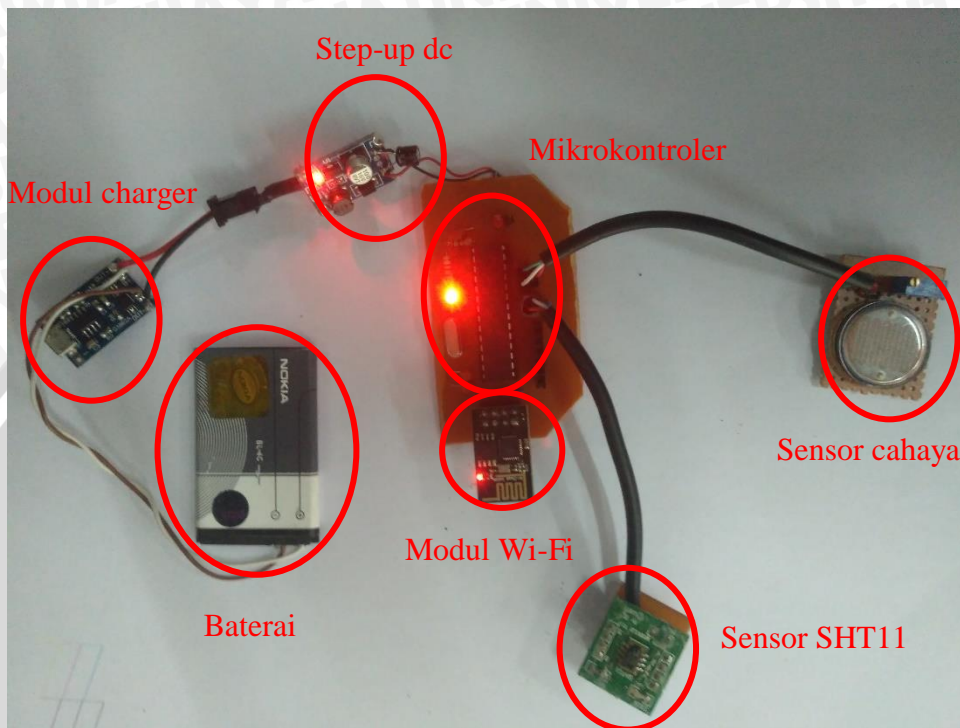

**Gambar 2.** Foto Keseluruhan Sistem



**LAMPIRAN 2 : Listing Program**

```

#include <SHT1x.h>
#include <SoftwareSerial.h>
#define DEBUG true
#define dataPin 6
#define clockPin 7
#define LDR_PIN A4
#define MAX_ADC_READING 1023
#define ADC_REF_VOLTAGE 3.3
#define REF_RESISTANCE 9996 // measure this for best results
#define LUX_CALC_SCALAR 12579201
#define LUX_CALC_EXPONENT 1.633
SHT1x sht1x(dataPin, clockPin);
String Wifi_SSID="Ngrimbi11";//Ganti dengan nama Wifi
String Wifi_PWD="pangahkok";
//Ganti dengan password Wifi
String apiKey = "HISXEEIZM7ZBUQPS";
//Ganti dengan channel thingspeak apiKey
const int inPin2 = A5;
const int inPin1 = A3;
SoftwareSerial esp8266 (9,8);

void setup()
{
  // pinMode(LED, OUTPUT);
  Serial.begin(9600);
  esp8266.begin(9600);
  //analogReference(INTERNAL);
  sendData("AT+RST\r\n",2000,DEBUG); // Modul Wifi direste
  sendData("AT+CWMODE=1\r\n",1000,DEBUG); // modul Wifi diatur sebagai client
  sendData("AT+CWJAP=\""+ Wifi_SSID + "\",\""+ Wifi_PWD + "\"\r\n",3000,DEBUG); // Menghubungkan ke router
  delay(1000);
  sendData("AT+CIFSR\r\n",1000,DEBUG); // Mendapatkan ip address
  sendData("AT+CIPMUX=1\r\n",1000,DEBUG); // Diatur untuk multiple connections
  sendData("AT+CIPSERVER=1,

```



```

80\r\n",1000,DEBUG); //Server
aktif di port 80
  Serial.println("Server ready");
}

void loop()
{
  int  ldrRawData;
  float      resistorVoltage,
ldrVoltage;
  float ldrResistance;
  float ldrLux;
  float temp_c;
  float temp_f;
  float humidity;
  int a = analogRead(inPin1);
  int b = analogRead(inPin2);
  int c = (a - 447) - b;
  float bat = c * (100.00 / 137.00);
  float volt = (bat/100) + 3.2;
  ldrRawData
analogRead(LDR_PIN);
  resistorVoltage
(float)ldrRawData
MAX_ADC_READING
ADC_REF_VOLTAGE;
  ldrVoltage
ADC_REF_VOLTAGE
resistorVoltage;
  ldrResistance
ldrVoltage/resistorVoltage
REF_RESISTANCE;
  ldrLux
LUX_CALC_SCALAR
pow(ldrResistance,
LUX_CALC_EXPONENT);
  temp_c
=
sht1x.readTemperatureC();
  temp_f
=
sht1x.readTemperatureF();
  humidity
=
sht1x.readHumidity();
  // TCP CONNECTION
  String  getThingSpeak
=
"AT+CIPSTART=4,\"TCP\", \"";
  getThingSpeak
+=
"184.106.153.149";
  //
api.thingspeak.com
  getThingSpeak += "\",80";
  Serial.print("TCP Connection =
");
  Serial.println(getThingSpeak);
  esp8266.println(getThingSpeak
);
  delay(2000); // Menunggu
selama 2 detik untuk
menyetabilkan koneksi antara
thingspeak dan esp8266
  if(esp8266.find("Error"))
  {
  Serial.println("AT+CIPSTART
error");
  return;
}

```

```

}
// UPDATE THINGSPEAK
CHANNEL WITH DATA
STRING
String dataToPush = "GET
/update?api_key=";
dataToPush += apiKey;
dataToPush += "&field1=";
dataToPush += String(temp_c);
dataToPush += "&field2=";
dataToPush += String(temp_f);
dataToPush += "&field3=";
dataToPush +=
String(humidity);
dataToPush += "&field4=";
dataToPush += String(bat);
dataToPush += "&field5=";
dataToPush += String(volt);
dataToPush += "&field6=";
dataToPush += String(ldrLux);
dataToPush += "&field7=";
dataToPush +=
String(ldrResistance);
dataToPush += "&field8=";
dataToPush +=
String(ldrVoltage);
dataToPush += "\r\n\r\n";
Serial.print("Data updated = ");
Serial.print(dataToPush);

// SEND DATA LENGTH
String sendData =
"AT+CIPSEND=4,";
sendData +=
String(dataToPush.length());
Serial.print("Data length = ");
Serial.println(sendData);
esp8266.println(sendData);
delay(2000); // Menunggu
selama 2 detik untuk
menyetabilkan koneksi antara
thingspeak dan esp8266
if(esp8266.find(">"))
{
esp8266.print(dataToPush);
}
else
{
esp8266.println("AT+CIPCLOS
E");
Serial.println("AT+CIPCLOSE"
); // alerting closing connection
}
delay(15000); // thingSpeak
needs minimum 15 sec delay
between updates
}

```

```
String sendData(String
command, const int timeout,
boolean debug)
{
    String response = "";

    esp8266.print(command); //
    send the read character to the
    esp8266

    long int time = millis();

    while( (time+timeout) >
millis())
    {
        while(esp8266.available())
        {
            char c = esp8266.read(); //
            read the next character.
            response+=c;
        }
        if(debug)
        {
            Serial.print(response);
        }
        return response;
    }
}
```







ATmega48A/PA/88A/PA/168A/PA/328/P

**ATMEL 8-BIT MICROCONTROLLER WITH 4/8/16/32KBYTES  
IN-SYSTEM PROGRAMMABLE FLASH**

**DATASHEET**

**Features**

- High Performance, Low Power Atmel® AVR® 8-Bit Microcontroller Family
- Advanced RISC Architecture
  - 131 Powerful Instructions – Most Single Clock Cycle Execution
  - 32 x 8 General Purpose Working Registers
  - Fully Static Operation
  - Up to 20 MIPS Throughput at 20MHz
  - On-chip 2-cycle Multiplier
- High Endurance Non-volatile Memory Segments
  - 4/8/16/32KBytes of In-System Self-Programmable Flash program memory
  - 256/512/512/1KBytes EEPROM
  - 512/1K/1K/2KBytes Internal SRAM
  - Write/Erase Cycles: 10,000 Flash/100,000 EEPROM
  - Data retention: 20 years at 85°C/100 years at 25°C<sup>(1)</sup>
  - Optional Boot Code Section with Independent Lock Bits
    - In-System Programming by On-chip Boot Program
    - True Read-While-Write Operation
  - Programming Lock for Software Security
- Atmel® QTouch® library support
  - Capacitive touch buttons, sliders and wheels
  - QTouch and QMatrix® acquisition
  - Up to 64 sense channels
- Peripheral Features
  - Two 8-bit Timer/Counters with Separate Prescaler and Compare Mode
  - One 16-bit Timer/Counter with Separate Prescaler, Compare Mode, and Capture Mode
  - Real Time Counter with Separate Oscillator
  - Six PWM Channels
  - 8-channel 10-bit ADC in TQFP and QFN/MLF package
    - Temperature Measurement
  - 6-channel 10-bit ADC in PDIP Package
    - Temperature Measurement
  - Programmable Serial USART
  - Master/Slave SPI Serial Interface
  - Byte-oriented 2-wire Serial Interface (Philips I<sup>2</sup>C compatible)
  - Programmable Watchdog Timer with Separate On-chip Oscillator
  - On-chip Analog Comparator
  - Interrupt and Wake-up on Pin Change



- Special Microcontroller Features
  - Power-on Reset and Programmable Brown-out Detection
  - Internal Calibrated Oscillator
  - External and Internal Interrupt Sources
  - Six Sleep Modes: Idle, ADC Noise Reduction, Power-save, Power-down, Standby, and Extended Standby
- I/O and Packages
  - 23 Programmable I/O Lines
  - 28-pin PDIP, 32-lead TQFP, 28-pad QFN/MLF and 32-pad QFN/MLF
- Operating Voltage:
  - 1.8 - 5.5V
- Temperature Range:
  - -40°C to 85°C
- Speed Grade:
  - 0 - 4MHz@1.8 - 5.5V, 0 - 10MHz@2.7 - 5.5.V, 0 - 20MHz @ 4.5 - 5.5V
- Power Consumption at 1MHz, 1.8V, 25°C
  - Active Mode: 0.2mA
  - Power-down Mode: 0.1µA
  - Power-save Mode: 0.75µA (Including 32kHz RTC)

## DT-SENSE SHT11 MODULE

**DT-Sense SHT11 Module** merupakan suatu modul sensor suhu dan kelembaban yang berbasis Sensirion SHT11 ([www.sensirion.com](http://www.sensirion.com)) dengan antarmuka Two-Wire Serial Interface. Modul ini dapat diaplikasikan dalam sistem pengendali suhu dalam ruang atau sistem weather station.

### Spesifikasi Hardware

1. Range suhu : -40°C (-40°F) hingga +123,8°C (+254,9°F)
2. Akurasi suhu : +/- 0,5°C pada 25°C
3. Range kelembaban : 0 hingga 100% RH
4. Akurasi RH absolut : +/- 3,5% RH
5. Faktor bentuk : 8 pin DIP - 0,6"
6. Konsumsi daya rendah (tipikal 30 µW)
7. Tegangan supply +5 VDC

### Tata Letak

Pin	Fungsi
1	Data
3	Clock
4	Ground
5	+5 VDC

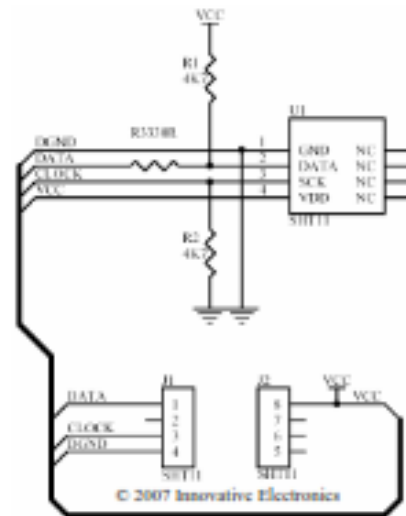

Aplikasi terdapat di [www.innovativeelectronics.com](http://www.innovativeelectronics.com).

- *Terima Kasih atas kepercayaan Anda menggunakan produk kami. Bila ada kesulitan, pertanyaan atau saran mengenai produk ini silakan menghubungi technical support kami :*

[support@innovativeelectronics.com](mailto:support@innovativeelectronics.com)

## DT-SENSE SHT11 MODULE

**DT-Sense SHT11 Module** merupakan suatu modul sensor suhu dan kelembaban yang berbasis Sensirion SHT11 ([www.sensirion.com](http://www.sensirion.com)) dengan antarmuka Two-Wire Serial Interface. Modul ini dapat diaplikasikan dalam sistem pengendali suhu dalam ruang atau sistem weather station.

### Spesifikasi Hardware

1. Range suhu : -40°C (-40°F) hingga +123,8°C (+254,9°F)
2. Akurasi suhu : +/- 0,5°C pada 25°C
3. Range kelembaban : 0 hingga 100% RH
4. Akurasi RH absolut : +/- 3,5% RH
5. Faktor bentuk : 8 pin DIP - 0,6"
6. Konsumsi daya rendah (tipikal 30 µW)
7. Tegangan supply +5 VDC

### Tata Letak

Pin	Fungsi
1	Data
3	Clock
4	Ground
5	+5 VDC

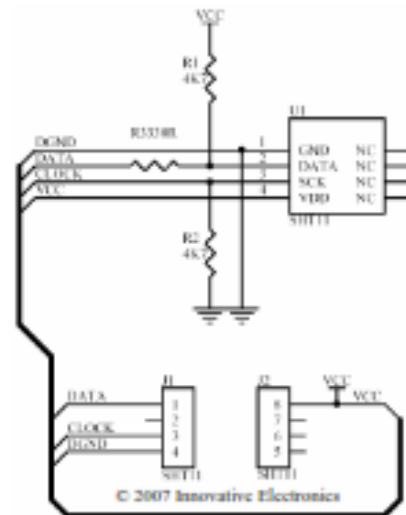
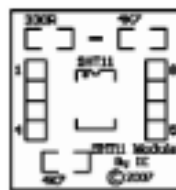

Aplikasi terdapat di [www.innovativeelectronics.com](http://www.innovativeelectronics.com).

- *Terima Kasih atas kepercayaan Anda menggunakan produk kami. Bila ada kesulitan, pertanyaan atau saran mengenai produk ini silakan menghubungi technical support kami :*

[support@innovativeelectronics.com](mailto:support@innovativeelectronics.com)





# ESP8266EX Datasheet

Version 4.3

Espressif Systems IOT Team

<http://bbs.espressif.com/>

Copyright © 2015





#### Disclaimer and Copyright Notice

Information in this document, including URL references, is subject to change without notice. THIS DOCUMENT IS PROVIDED "AS IS" WITH NO WARRANTIES WHATSOEVER, INCLUDING ANY WARRANTY OF MERCHANTABILITY, NON-INFRINGEMENT, FITNESS FOR ANY PARTICULAR PURPOSE, OR ANY WARRANTY OTHERWISE ARISING OUT OF ANY PROPOSAL, SPECIFICATION OR SAMPLE. All liability, including liability for infringement of any proprietary rights, relating to use of information in this document is disclaimed. No licenses express or implied, by estoppel or otherwise, to any intellectual property rights are granted herein.

The Wi-Fi Alliance Member Logo is a trademark of the WiFi Alliance.

All trade names, trademarks and registered trademarks mentioned in this document are property of their respective owners, and are hereby acknowledged.

Copyright © 2015 Espressif Systems. All rights reserved.





## Table of Contents

1. General Overview .....	6
1.1. Introduction .....	6
1.2. Features .....	7
1.3. Parameters .....	7
1.4. Ultra Low Power Technology .....	9
1.5. Major Applications .....	9
2. Hardware Overview .....	11
2.1. Pin Definitions .....	11
2.2. Electrical Characteristics .....	13
2.3. Power Consumption .....	13
2.4. Receiver Sensitivity .....	14
2.5. MCU .....	15
2.6. Memory Organization .....	15
2.6.1. Internal SRAM and ROM .....	15
2.6.2. External SPI Flash .....	15
2.7. AHB and AHB Blocks .....	16
3. Pins and Definitions .....	17
3.1. GPIO .....	17
3.1.1. General Purpose Input/Output Interface (GPIO) .....	17







3.2.	Secure Digital Input/Output Interface (SDIO) .....	18
3.3.	Serial Peripheral Interface (SPI/HSPI).....	18
3.3.1.	General SPI (Master/Slave).....	18
3.3.2.	SDIO / SPI (Slave).....	19
3.3.3.	HSPI (Master/Slave).....	19
3.4.	Inter-integrated Circuit Interface (I2C).....	19
3.5.	I2S .....	20
3.6.	Universal Asynchronous Receiver Transmitter (UART).....	20
3.7.	Pulse-Width Modulation (PWM).....	21
3.8.	IR Remote Control .....	22
3.9.	ADC (Analog-to-digital Converter) .....	22
3.10.	LED Light and Button .....	24
4.	Firmware & Software Development Kit.....	26
4.1.	Features.....	26
5.	Power Management .....	27
6.	Clock Management .....	28
6.1.	High Frequency Clock.....	28
6.2.	External Reference Requirements.....	29
7.	Radio.....	29
7.1.	Channel Frequencies .....	30
7.2.	2.4 GHz Receiver .....	30
7.3.	2.4 GHz Transmitter .....	30





Espressif Systems

ESP8266 Datasheet

7.4.	Clock Generator.....	30
8.	Appendix: QFN32 Package Size .....	31





## 1. General Overview

### 1.1. Introduction

Espressif Systems' Smart Connectivity Platform (ESCP) is a set of high performance, high integration wireless SOCs, designed for space and power constrained mobile platform designers. It provides unsurpassed ability to embed WiFi capabilities within other systems, or to function as a standalone application, with the lowest cost, and minimal space requirement.

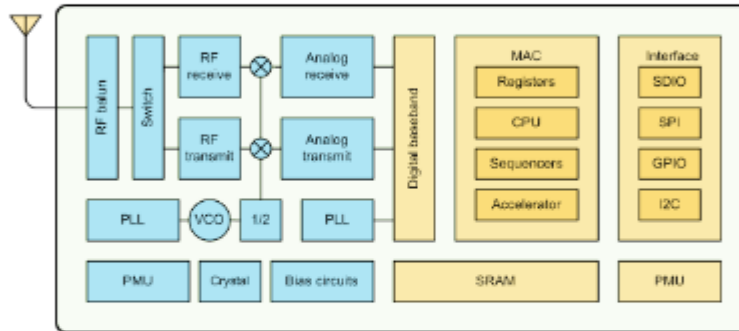

Figure 1 ESP8266EX Block Diagram

ESP8266EX offers a complete and self-contained WiFi networking solution; it can be used to host the application or to offload WiFi networking functions from another application processor.

When ESP8266EX hosts the application, it boots up directly from an external flash. It has integrated cache to improve the performance of the system in such applications.

Alternately, serving as a WiFi adapter, wireless internet access can be added to any micro controller-based design with simple connectivity (SPI/SDIO or I2C/UART interface).

ESP8266EX is among the most integrated WiFi chip in the industry; it integrates the antenna switches, RF balun, power amplifier, low noise receive amplifier, filters, power management modules, it requires minimal external circuitry, and the entire solution, including front-end module, is designed to occupy minimal PCB area.

ESP8266EX also integrates an enhanced version of Tensilica's L106 Diamond series 32-bit processor, with on-chip SRAM, besides the WiFi functionalities. ESP8266EX is often integrated with external sensors and other application specific devices through its GPIOs; sample codes for such applications are provided in the software development kit (SDK).





Espressif Systems' Smart Connectivity Platform (ESCP) demonstrates sophisticated system-level features include fast sleep/wake context switching for energy-efficient VoIP, adaptive radio biasing for low-power operation, advance signal processing, and spur cancellation and radio co-existence features for common cellular, Bluetooth, DDR, LVDS, LCD interference mitigation.

### 1.2. Features

- 802.11 b/g/n
- Integrated low power 32-bit MCU
- Integrated 10-bit ADC
- Integrated TCP/IP protocol stack
- Integrated TR switch, balun, LNA, power amplifier and matching network
- Integrated PLL, regulators, and power management units
- Supports antenna diversity
- WiFi 2.4 GHz, support WPA/WPA2
- Support STA/AP/STA+AP operation modes
- Support Smart Link Function for both Android and iOS devices
- SDIO 2.0, (H) SPI, UART, I2C, I2S, IR Remote Control, PWM, GPIO
- STBC, 1x1 MIMO, 2x1 MIMO
- A-MPDU & A-MSDU aggregation & 0.4s guard interval
- Deep sleep power <10uA, Power down leakage current < 5uA
- Wake up and transmit packets in < 2ms
- Standby power consumption of < 1.0mW (DTIM3)
- +20 dBm output power in 802.11b mode
- Operating temperature range -40C – 125C
- FCC, CE, TELEC, WiFi Alliance, and SRRC certified

### 1.3. Parameters

Table 1 Parameters





Categories	Items	Values
WiFi Parameters	Certificates	FCC/CE/TELEC/SRRC
	WiFi Protocols	802.11 b/g/n
	Frequency Range	2.4G-2.5G (2400M-2483.5M)
	Tx Power	802.11 b: +20 dBm
		802.11 g: +17 dBm
		802.11 n: +14 dBm
	Rx Sensitivity	802.11 b: -91 dbm (11 Mbps)
802.11 g: -75 dbm (54 Mbps)		
802.11 n: -72 dbm (MCS7)		
Types of Antenna	PCB Trace, External, IPEX Connector, Ceramic Chip	
Hardware Parameters	Peripheral Bus	UART/SDIO/SPI/I2C/I2S/IR Remote Control
		GPIO/PWM
	Operating Voltage	3.0~3.6V
	Operating Current	Average value: 80mA
	Operating Temperature Range	-40°~125°
	Ambient Temperature Range	Normal temperature
	Package Size	5x5mm
	External Interface	N/A
Software Parameters	WiFi mode	station/softAP/SoftAP+station
	Security	WPA/WPA2
	Encryption	WEP/TKIP/AES
	Firmware Upgrade	UART Download / OTA (via network)
	Ssoftware Development	Supports Cloud Server Development / SDK for custom firmware development
	Network Protocols	IPv4, TCP/UDP/HTTP/FTP





User Configuration	AT Instruction Set, Cloud Server, Android/iOS App
--------------------	---------------------------------------------------

**1.4. Ultra Low Power Technology**

ESP8266EX has been designed for mobile, wearable electronics and Internet of Things applications with the aim of achieving the lowest power consumption with a combination of several proprietary techniques. The power saving architecture operates mainly in 3 modes: active mode, sleep mode and deep sleep mode.

By using advance power management techniques and logic to power-down functions not required and to control switching between sleep and active modes, ESP8266EX consumes about than 60uA in deep sleep mode (with RTC clock still running) and less than 1.0mA (DTIM=3) or less than 0.5mA (DTIM=10) to stay connected to the access point.

When in sleep mode, only the calibrated real-time clock and watchdog remains active. The real-time clock can be programmed to wake up the ESP8266EX at any required interval.

The ESP8266EX can be programmed to wake up when a specified condition is detected. This minimal wake-up time feature of the ESP8266EX can be utilized by mobile device SOCs, allowing them to remain in the low-power standby mode until WiFi is needed.

In order to satisfy the power demand of mobile and wearable electronics, ESP8266EX can be programmed to reduce the output power of the PA to fit various application profiles, by trading off range for power consumption.

**1.5. Major Applications**

Major fields of ESP8266EX applications to Internet-of-Things include:

- Home Appliances
- Home Automation
- Smart Plug and lights
- Mesh Network
- Industrial Wireless Control
- Baby Monitors
- IP Cameras
- Sensor Networks
- Wearable Electronics







Espressif Systems

ESP8266 Datasheet

- WiFi Location-aware Devices
- Security ID Tags
- WiFi Position System Beacons





## 2. Hardware Overview

### 2.1. Pin Definitions

The pin assignments for 32-pin QFN package is illustrated in Fig.2.

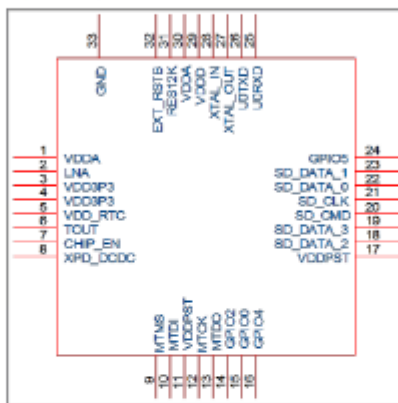

Figure 2 Pin Assignments

Table 2 below presents an overview on the general pin attributes and the functions of each pin.

Table 2 Pin Definitions

Pin	Name	Type	Function
1	VDDA	P	Analog Power 3.0 ~3.6V
2	LNA	I/O	RF Antenna Interface. Chip Output Impedance=50Ω No matching required but we recommend that the n-type matching network is retained.
3	VDD3P3	P	Amplifier Power 3.0~3.6V
4	VDD3P3	P	Amplifier Power 3.0~3.6V
5	VDD_RTC	P	NC (1.1V)





6	TOUT	I	ADC Pin (note: an internal pin of the chip) can be used to check the power voltage of VDD3P3 (Pin 3 and Pin4) or the input voltage of TOUT (Pin 6). These two functions cannot be used simultaneously.
7	CHIP_EN	I	Chip Enable. High: On, chip works properly; Low: Off, small current
8	XPD_DCDC	I/O	Deep-Sleep Wakeup; GPIO16
9	MTMS	I/O	GPIO14; HSPI_CLK
10	MTDI	I/O	GPIO12; HSPI_MISO
11	VDDPST	P	Digital/IO Power Supply (1.8V-3.3V)
12	MTCK	I/O	GPIO13; HSPI_MOSI; UART0_CTS
13	MTDO	I/O	GPIO15; HSPI_CS; UART0_RTS
14	GPIO2	I/O	UART Tx during flash programming; GPIO2
15	GPIO0	I/O	GPIO0; SPI_CS2
16	GPIO4	I/O	GPIO4
17	VDDPST	P	Digital/IO Power Supply (1.8V-3.3V)
18	SDIO_DATA_2	I/O	Connect to SD_D2 (Series R: 200Q); SPIHD; HSPIHD; GPIO9
19	SDIO_DATA_3	I/O	Connect to SD_D3 (Series R: 200Q); SPIWP; HSPIWP; GPIO10
20	SDIO_CMD	I/O	Connect to SD_CMD (Series R: 200Q); SPL_CS0; GPIO11
21	SDIO_CLK	I/O	Connect to SD_CLK (Series R: 200Q); SPI_CLK; GPIO6
22	SDIO_DATA_0	I/O	Connect to SD_D0 (Series R: 200Q); SPL_MSI0; GPIO7
23	SDIO_DATA_1	I/O	Connect to SD_D1 (Series R: 200Q); SPL_MOSI; GPIO8
24	GPIO5	I/O	GPIO5
25	U0RXD	I/O	UART Rx during flash programming; GPIO3
26	U0TXD	I/O	UART Tx during flash programming; GPIO1; SPL_CS1
27	XTAL_OUT	I/O	Connect to crystal oscillator output, can be used to provide BT clock input
28	XTAL_IN	I/O	Connect to crystal oscillator input
29	VDDD	P	Analog Power 3.0V-3.6V
30	VDDA	P	Analog Power 3.0V-3.6V
31	RES12K	I	Serial connection with a 12 kΩ resistor and connect to the ground
32	EXT_RSTB	I	External reset signal (Low voltage level: Active)







Note: GPIO2, GPIO0, MTDO can be configurable as 3-bit SDIO mode.

### 2.2. Electrical Characteristics

Table 3 ESP8266EX Electrical Characteristics

Parameters	Conditions	Min	Typical	Max	Unit
Storage Temperature Range		-40	Normal	125	°C
Maximum Soldering Temperature	IPC/JEDEC J-STD-020			260	°C
Working Voltage Value		3.0	3.3	3.6	V
I/O	$V_{L}/V_{IH}$	-0.3/0.75V <sub>IO</sub>		0.25V <sub>IO</sub> /3.6	V
	$V_{OL}/V_{OH}$	N/0.8V <sub>IO</sub>		0.1V <sub>IO</sub> /N	
	$I_{MAX}$			12	mA
Electrostatic Discharge (HBM)	TAMB=25°C			2	KV
Electrostatic Discharge (CDM)	TAMB=25°C			0.5	KV

### 2.3. Power Consumption

The following current consumption is based on 3.3V supply, and 25°C ambient, using internal regulators. Measurements are done at antenna port without SAW filter. All the transmitter's measurements are based on 90% duty cycle, continuous transmit mode.

Table 4 Description on Power Consumption

Parameters	Min	Typical	Max	Unit
Tx 802.11b, CCK 11Mbps, P OUT=+17dBm		170		mA
Tx 802.11g, OFDM 54Mbps, P OUT =+15dBm		140		mA
Tx 802.11n, MCS7, P OUT =+13dBm		120		mA
Rx 802.11b, 1024 bytes packet length, -80dBm		50		mA
Rx 802.11g, 1024 bytes packet length, -70dBm		56		mA
Rx 802.11n, 1024 bytes packet length, -65dBm		56		mA
Modem-Sleep①		15		mA
Light-Sleep②		0.9		mA
Deep-Sleep③		10		uA
Power Off		0.5		uA





- ①: Modem-Sleep requires the CPU to be working, as in PWM or I2S applications. According to 802.11 standards (like U-APSD), it saves power to shut down the WiFi Modem circuit while maintaining a WiFi connection with no data transmission. E.g. in DTIM3, to maintain a sleep 300ms-wake 3ms cycle to receive AP's Beacon packages, the current is about 15mA
- ②: During Light-Sleep, the CPU may be suspended in applications like WiFi switch. Without data transmission, the WiFi Modem circuit can be turned off and CPU suspended to save power according to the 802.11 standard (U-APSD). E.g. in DTIM3, to maintain a sleep 300ms-wake 3ms cycle to receive AP's Beacon packages, the current is about 0.9mA.
- ③: Deep-Sleep does not require WiFi connection to be maintained. For application with long time lags between data transmission, e.g. a temperature sensor that checks the temperature every 100s, sleep 300s and waking up to connect to the AP (taking about 0.3-1s), the overall average current is less than 1mA.

#### 2.4. Receiver Sensitivity

The following are measured under room temperature conditions with 3.3V and 1.1V power supplies.

Table 5 Receiver Sensitivity

Parameters	Min	Typical	Max	Unit
Input frequency	2412		2484	MHz
Input impedance		50		$\Omega$
Input reflection			-10	dB
Output power of PA for 72.2Mbps	15.5	16.5	17.5	dBm
Output power of PA for 11b mode	19.5	20.5	21.5	dBm
Sensitivity				
DSSS, 1Mbps		-98		dBm
CCK, 11Mbps		-91		dBm
6Mbps (1/2 BPSK)		-93		dBm
54Mbps (3/4 64-QAM)		-75		dBm
HT20, MCS7 (65Mbps, 72.2Mbps)		-72		dBm
Adjacent Channel Rejection				
OFDM, 6Mbps		37		dB
OFDM, 54Mbps		21		dB
HT20, MCS0		37		dB
HT20, MCS7		20		dB





## 2.5. MCU

ESP8266EX is embedded with Tensilica L106 32-bit micro controller (MCU), which features extra low power consumption and 16-bit RSIC. The CPU clock speed is 80MHz. It can also reach a maximum value of 160MHz. Real Time Operation System (RTOS) is enabled. Currently, only 20% of MIPS has been occupied by the WiFi stack, the rest can all be used for user application programming and development. The following interfaces can be used to connect to the MCU embedded in ESP8266EX:

- Programmable RAM/ROM interfaces (iBus), which can be connected with memory controller, and can also be used to visit external flash;
- Data RAM interface (dBus), which can connected with memory controller;
- AHB interface, can be used to visit the register.

## 2.6. Memory Organization

### 2.6.1. Internal SRAM and ROM

ESP8266EX WiFi SoC is embedded with memory controller, including SRAM and ROM. MCU can visit the memory units through iBus, dBus, and AHB interfaces. All memory units can be visited upon request, while a memory arbiter will decide the running sequence according to the time when these requests are received by the processor.

According to our current version of SDK provided, SRAM space that is available to users is assigned as below:

- **RAM size < 36kB**, that is to say, when ESP8266EX is working under the station mode and is connected to the router, programmable space accessible to user in heap and data section is around 36kB.)
- There is no programmable ROM in the SoC, therefore, user program must be stored in an external SPI flash.

### 2.6.2. External SPI Flash

An external SPI flash is used together with ESP8266EX to store user programs. Theoretically speaking, up to 16 Mbyte memory capacity can be supported.

**Suggested SPI Flash memory capacity:**

- OTA is disabled: the minimum flash memory that can be supported is 512 kByte;
- OTA is enabled: the minimum flash memory that can be supported is 1 Mbyte.

Several SPI modes can be supported, including Standard SPI, Dual SPI, DIO SPI, QIO SPI, and Quad SPL







Therefore, please choose the correct SPI mode when you are downloading into the flash, otherwise firmwares/programs that you downloaded may not work in the right way.

### 2.7. AHB and APB Blocks

The AHB block performs the function of an arbiter, controls the AHB interfaces from the MAC, SDIO (host) and CPU. Depending on the address, the AHB data requests can go into one of the two slaves: APB block, or

flash controller (usually for standalone applications).

Data requests to the memory controller are usually high speed requests, and requests to the APB block are usually register access.

The APB block acts as a decoder. It is meant only for access to programmable registers within ESP8266's main blocks. Depending on the address, the APB request can go to the radio, SI/SPI, SDIO (host), GPIO, UART, real-time clock (RTC), MAC or digital baseband.





### 3. Pins and Definitions

The chipset encapsulates variable analog and data transmission I/Os, descriptions and definitions of which are explained below in detail.

#### 3.1. GPIO

##### 3.1.1. General Purpose Input/Output Interface (GPIO)

There are up to 17 GPIO pins. They can be assigned to various functions by the firmware. Each GPIO can be configured with internal pull-up (except XPD\_DCDC, which is configured with internal pull-down), input available for sampling by a software register, input triggering an edge or level CPU interrupt, input triggering a level wakeup interrupt, open-drain or push-pull output driver, or output source from a software register, or a sigma-delta PWM DAC.

These pins are multiplexed with other functions such as I2C, I2S, UART, PWM, IR Remote Control, etc. Data I/O soldering pad is bidirectional and tri-state that include data input and output controlling buffer. Besides, I/O can be set as a specific state and remains like this. For example, if you intend to lower the power consumption of the chip, all data input and output enable signals can be set as remaining low power state. You can transport some specific state into the I/O. When the I/O is not powered by external circuits, the I/O will remain to be the state that it was used the last time. Some positive feedback is generated by the state-remaining function of the pins, therefore, if the external driving power must be stronger than the positive feedback. Even so, the driving power that is needed is within 5uA.

Table 6 Pin Definitions of GPIOs

Variables	Symbol	Min	Max	Unit
Input Low Voltage	$V_{IL}$	-0.3	$0.25 \times V_{IO}$	V
Input High Voltage	$V_{IH}$	$0.75 \times V_{IO}$	3.3	V
Input Leakage Current	$I_{IL}$		50	nA
Output Low Voltage	$V_{OL}$		$0.1 \times V_{IO}$	V
Output High Voltage	$V_{OH}$	$0.8 \times V_{IO}$		V
Input Pin Resistance Value	$C_{pad}$		2	pF
VDDIO	$V_{IO}$	1.8	3.3	V
Maximum Driving Power	$I_{MAX}$		12	mA
Temperature	$T_{amb}$	-40	125	°C

All digital IO pins are protected from over-voltage with a snap-back circuit connected between the pad and ground. The snap back voltage is typically about 6V, and the holding voltage is 5.8V. This





provides protection from over-voltages and ESD. The output devices are also protected from reversed voltages with diodes.

### 3.2. Secure Digital Input/Output Interface (SDIO)

One Slave SDIO has been defined by ESP8266EX, the definitions of which are described in Table 7 below. 4bit 25MHz SDIO v1.1 and 4bit 50MHz SDIO v2.0 are supported.

Table 7 Pin Definitions of SDIOs

Pin Name	Pin Num	IO	Function Name
SDIO_CLK	21	IO6	SDIO_CLK
SDIO_DATA0	22	IO7	SDIO_DATA0
SDIO_DATA1	23	IO8	SDIO_DATA1
SDIO_DATA_2	18	IO9	SDIO_DATA_2
SDIO_DATA_3	19	IO10	SDIO_DATA_3
SDIO_CMD	20	IO11	SDIO_CMD

### 3.3. Serial Peripheral Interface (SPI/HSPI)

Currently, one general Slave/Master SPI, one Slave SDID/SPI, and one general Slave/Master HSPI have been defined by ESP8266EX. Functions of all these pins can be implemented via hardware. The pin definitions are described below:

#### 3.3.1. General SPI (Master/Slave)

Table 8 Pin Definitions of General SPIs

Pin Name	Pin Num	IO	Function Name
SDIO_CLK	21	IO6	SPICLK
SDIO_DATA0	22	IO7	SPIQ/MISO
SDIO_DATA1	23	IO8	SPID/MOSI
SDIO_DATA_2	18	IO9	SPIHD
SDIO_DATA_3	19	IO10	SPIWP
SDIO_CMD	20	IO11	SPICS0
U0TXD	26	IO1	SPICS1
GPIO0	15	IO0	SPICS2







### 3.3.2. SDIO / SPI (Slave)

Table 9 Pin Definitions of SDIO / SPI (Slave)

Pin Name	Pin Num	IO	Function Name
SDIO_CLK	21	IO6	SPI_SLAVE_CLK
SDIO_DATA0	22	IO7	SPI_SLAVE_MISO
SDIO_DATA1	23	IO8	SPI_SLAVE_INT
SDIO_DATA_2	18	IO9	NC
SDIO_DATA_3	19	IO10	SPI_SLAVE_CS
SDIO_CMD	20	IO11	SPI_SLAVE_MOSI

### 3.3.3. HSPI (Master/Slave)

Table 10 Pin Definitions of HSPI (Master/Slave)

Pin Name	Pin Num	IO	Function Name
MTMS	9	IO14	HSPICLK
MTDI	10	IO12	HSPIQ/MISO
MTCK	12	IO13	HSPID/MOSI
MTDO	13	IO15	HPSICS

**Note:**

- SPI mode can be implemented via software programming. The clock frequency can reach up to a maximum value of 80MHz.
- Function of Slave SDIO/SPI interface can be implemented via hardware, and linked list DMA (Direct Memory Access) is supported, software overheads are smaller. However, there is no linked list DMA on general SPI and HSPI, and the software overheads are larger, therefore, the data transmitting speed will be restrained by software processing speed.

### 3.4. Inter-integrated Circuit Interface (I2C)

One I2C, which is mainly used to connect with micro controller and other peripheral equipment such as sensors, is defined by ESP8266EX. The present pin definition of I2C is as defined below:





Table 11 Pin Definitions of I2C

Pin Name	Pin Num	IO	Function Name
MTMS	9	IO14	I2C_SCL
GPIO2	14	IO2	I2C_SDA

Both I2C-Master and I2C-Slave are supported. I2C interface functionality can be realized via software programming, the clock frequency can be up to around 100KHz at most. It should be noted that I2C clock frequency should be higher than the slowest clock frequency of the slave device.

### 3.5. I2S

Currently one I2S data input interface and one I2S data output interface are defined. I2S interface is mainly used in applications such as data collection, processing, and transmission of audio data, as well as the input and output of serial data. For example, LED lights (WS2812 series) are supported. The pin definition of I2S is as defined below:

Table 12 Pin Definitions of I2S

I2S Data Input:			
Pin Name	Pin Num	IO	Function Name
MTDI	10	IO12	I2SI_DATA
MTCK	12	IO13	I2SI_BCK
MTMS	9	IO14	I2SI_WS
I2S Data Output:			
Pin Name	Pin Num	IO	Function Name
MTDO	13	IO15	I2SO_BCK
U0RXD	25	IO3	I2SO_DATA
GPIO2	14	IO2	I2SO_WS

I2S functionality can be realized via software programming, the GPIOs that will be used are multiplexed, and linked list DMA is supported.

### 3.6. Universal Asynchronous Receiver Transmitter (UART)

Two UART interfaces, UART0 and UART1, have been defined by ESP8266EX, the definitions are as below:





Table 13 Pin Definitions of UART Interfaces

Pin Type	Pin Name	Pin Num	IO	Function Name
UART0	U0RXD	25	IO3	U0RXD
	U0TXD	26	IO1	U0TXD
	MTDO	13	IO15	U0RTS
	MTCK	12	IO13	U0CTS
UART1	GPIO2	14	IO2	U1TXD
	SD_D1	23	IO8	U1RXD

Data transfers to/from UART interfaces can be implemented via hardware. The data transmission speed via UART interfaces can reach 115200\*40 (4.5Mbps).

UART0 can be for communication. It supports fluid control. Since UART1 features only data transmit signal (Tx), it is usually used for printing log.

Notes: By default, UART0 will output some printed information when the device is powered on and is booting up. The baud rate of the printed information is closely related to the frequency of the external crystal oscillator. If the frequency of the crystal oscillator is 40MHz, then the baud rate for printing is 115200; if the frequency of the crystal oscillator is 26MHz, then the baud rate for printing is 74880. If the printed information exerts any influence on the functionality of your device, you'd better block the printing during the power-on period by changing (U0TXD, U0RXD) to (MTDO, MTCK).

### 3.7. Pulse-Width Modulation (PWM)

Four PWM output interfaces have been defined by ESP8266EX. They can be extended by users themselves. The present pin definitions of the PWM interfaces are defined as below:

Table 14 Pin Definitions of PWM Interfaces

Pin Name	Pin Num	IO	Function Name
MTDI	10	IO12	PWM0
MTDO	13	IO15	PWM1
MTMS	9	IO14	PWM2
GPIO4	16	IO4	PWM3

The functionality of PWM interfaces can be implemented via software programming. For example, in the LED smart light demo, the function of PWM is realized by interruption of the timer, the minimum resolution can reach as much as 44 ns. PWM frequency range is adjustable from 1000 us to 10000 us,







i.e., between 100Hz and 1KHz. When the PWM frequency is at 1 KHz, the duty ratio will reach 1/22727, and over 14 bit resolution will be achieved at 1KHz refresh rate.

### 3.8. IR Remote Control

Currently, only one infrared remote control interface is defined, the pin definition is as below:

Table 14 Pin Definition of IR Remote Control

Pin Name	Pin Num	IO	Function Name
MTMS	9	IO12	IR Tx
GPIO5	24	IO5	IR Rx

The functionality of Infrared remote control interface can be implemented via software programming. NEC coding, modulation, and demodulation are used by this interface. The frequency of modulated carrier signal is 38KHz, while the duty ratio of the square wave is 1/3. The length of data transmission, which is around 1m, is determined by two factors: one is the maximum value of rated current, the other is internal current-limiting resistance value in the infrared receiver. The larger the resistance value, the lower the current, so is the power, and vice versa. The transmission angle is between 15° and 30°, and is mainly determined by the radiation direction of the infrared receiver.

**Notes:** Among the eight interfaces mentioned above, most of them can be multiplexed. Pin definitions that can be defined is not limited to the eight ones herein mentioned, customers can self customise the functions of the pins according to their specific application scenarios. Functions of these pins can be implemented via software programming and hardware.

### 3.9. ADC (Analog-to-digital Converter)

ESP8266EX is embedded with a 10-bit precision SARADC. Currently, TOUT (Pin6) is defined as ADC interface, the definition of which is described below:

Pin Name	Pin Num	Function Name
TOUT	6	ADC Interface

Table 16 Pin Definition of ADC

The following two applications can be implemented using ADC (Pin6). However, these two applications cannot be implemented concurrently.

- Test the power supply voltage of VDD3P3 (Pin 3 and Pin 4).

The function used to test the power supply voltage on PA\_VDD pin is: `uint16 system_get_vdd33(void)`

- Test the input voltage of TOUT (Pin 6):





The function used to test the input voltage of TOUT is: `uint16 system_adc_read(void)`  
**RF-init** parameter in the following passage refers to `esp_init_data_default.bin`

**Application One:** Test the power supply voltage of VDD3P3 (Pin 3 and Pin 4).  
**Hardware Design:** TOUT must be dangled.  
**RF-init Parameter:** The 107th byte of `esp_init_data_default.bin` (0 - 127 byte), "vdd33\_const", must set to be 0xFF, i.e., the value of "vdd33\_const" is 255.  
**RF Calibration Process:** Optimize the RF circuit conditions based on the testing results of VDD3P3 (Pin 3 and Pin 4).  
**User Programming:** Use `system_get_vdd33` instead of `system_adc_read`.

**Application Two:** Test the input voltage of TOUT (Pin 6).  
**Hardware Design:** The input voltage range is 0 to 1.0 V when TOUT is connected to external circuit.  
**RF-init Parameter:** The value of the 107th byte of `esp_init_data_default.bin` (0 - 127 byte), "vdd33\_const", must be set to be the real power supply voltage of Pin 3 and Pin 4.  
 The working power voltage range of ESP8266EX is between 1.8V and 3.6V, while the unit of "vdd33\_const" is 0.1V, therefore, the effective value range of "vdd33\_const" is 18 to 36.  
**RF Calibration Process:** Optimize the RF circuit conditions based on the value of "vdd33\_const". The permissible error is  $\pm 0.2V$ .  
**User Programming:** Use `system_adc_read` instead of `system_get_vdd33`.

**Note One:**

In **RF\_init** parameter `esp_init_data_default.bin` (0 - 127 byte), the 107th byte is defined as "vdd33\_const". Definitions of "vdd33\_const" is described below:

(1) If `vdd33_const = 0xff`, the power voltage of Pin 3 and Pin 4 will be tested by the internal self-calibration process of ESP8266EX chipset itself. RF circuit conditions should be optimized according to the testing results.





(2) If  $18 \leq \text{vdd33\_const} \leq 36$ , ESP8266EX RF Calibration and optimization process is implemented via  $(\text{vdd33\_const}/10)$ .

(3) If  $\text{vdd33\_const} < 18$  or  $36 < \text{vdd33\_const} < 255$ , ESP8266EX RF Calibration and optimization process is implemented via the default value 3.0V.

**Note Two:**

Function `system_get_vdd33` is used to test the power supply voltage of VDD3P3 (Pin 3 and Pin 4). Details on this function are described below:

(1) Pin Tout must be dangled. The 107th byte of `esp_init_data_default.bin` (0 - 127 byte), "vdd33\_const", must set to be 0xFF.

(2) If the 107th byte of `esp_init_data_default.bin` (0 - 127 byte), "vdd33\_const", is equal to 0xFF, the returned value of function `system_get_vdd33` will be an effective value, otherwise 0xffff will be returned.

(3) The unit of the returned value is: 1/1024 V.

**Note Three:**

Function `system_adc_read` is defined to test the input voltage of Pin TOUT (Pin 6). Details on this function are described below:

(1) The value of the 107th byte of `esp_init_data_default.bin` (0 - 127 byte), "vdd33\_const", must be set to be the real power supply voltage of Pin 3 and Pin 4.

(2) If the 107th byte of `esp_init_data_default.bin` (0 - 127 byte), "vdd33\_const", is NOT equal to 0xFF, the returned value of `system_adc_read` will be an effective value of the input voltage of Pin TOUT, otherwise 0xffff will be returned.

(3) The unit of the returned value is: 1/1024 V.

### 3.10. LED Light and Button

ESP8266EX features up to 17 GPIOs, all of which can be assigned to realise various functions of LED lights and buttons. Definitions of some GPIOs that are assigned with certain functions in our demo application design are shown below:

Table 17 Pin Definitions of LED and Button

Pin Name	Pin Num	IO	Function Name
MTCK	12	IO13	Button (Reset)
GPIO0	15	IO0	WiFi Light
MTDI	10	IO12	Link Light





**Espressif Systems**

ESP8266 Datasheet

Altogether three interfaces have been defined, one is for the button, and the other two is for LED light. Generally, **MTCK** is used to control the reset button, **GPIO0** is used as a signal to indicate the WiFi working state, **MTDI** is used as a signal light to indicate communication between the device and the server.

Note: Among the nine interfaces mentioned above, most of them can be multiplexed. Pin definitions that can be defined is not limited to the eight ones herein mentioned, customers can self customise the functions of the pins according to their specific application scenarios. Functions of these pins can be implemented via software programming and hardware.





#### 4. Firmware & Software Development Kit

The application and firmware is executed in on-chip ROM and SRAM, which loads the instructions during wake-up, through the SDIO interface, from the external flash.

The firmware implements TCP/IP, the full 802.11 b/g/n/e/i WLAN MAC protocol and WiFi Direct specification. It supports not only basic service set (BSS) operations under the distributed control function (DCF) but also P2P group operation compliant with the latest WiFi P2P protocol. Low level protocol functions are handled automatically by ESP8266:

- RTS/CTS
- acknowledgement
- fragmentation and defragmentation
- aggregation
- frame encapsulation (802.11h/RFC 1042)
- automatic beacon monitoring / scanning, and
- P2P WiFi direct

Passive or active scanning, as well as P2P discovery procedure is performed autonomously once initiated by the appropriate command. Power management is handled with minimum host interaction to minimize active duty period.

##### 4.1. Features

The SDK includes the following library functions:

- 802.11 b/g/n/d/e/i/k/r support;
- WiFi Direct (P2P) support:
  - P2P Discovery, P2P Group Owner mode, P2P Power Management
- Infrastructure BSS Station mode / P2P mode / softAP mode support;
- Hardware accelerators for CCMP (CBC-MAC, counter mode), TKIP (MIC, RC4), WAPI (SMS4), WEP (RC4), CRC;
- WPA/WPA2 PSK, and WPS driver;
- Additional 802.11i security features such as pre-authentication, and TSN;
- Open Interface for various upper layer authentication schemes over EAP such as TLS, PEAP, LEAP, SIM, AKA, or customer specific;
- 802.11n support (2.4GHz);
- Supports MIMO 1x1 and 2x1, STBC, A-MPDU and A-MSDU aggregation and 0.4μs guard interval;





- WMM power save U-APSD;
- Multiple queue management to fully utilize traffic prioritization defined by 802.11e standard;
- UMA compliant and certified;
- 802.1h/RFC1042 frame encapsulation;
- Scattered DMA for optimal CPU off load on Zero Copy data transfer operations;
- Antenna diversity and selection (software managed hardware);
- Clock/power gating combined with 802.11-compliant power management dynamically adapted to current connection condition providing minimal power consumption;
- Adaptive rate fallback algorithm sets the optimum transmission rate and Tx power based on actual SNR and packet loss information;
- Automatic retransmission and response on MAC to avoid packet discarding on slow host environment;
- Seamless roaming support;
- Configurable packet traffic arbitration (PTA) with dedicated slave processor based design provides flexible and exact timing Bluetooth co-existence support for a wide range of Bluetooth Chip vendors;
- Dual and single antenna Bluetooth co-existence support with optional simultaneous receive (WiFi/Bluetooth) capability.

## 5. Power Management

The chip can be put into the following states:

- **OFF:** CHIP\_PD pin is low. The RTC is disabled. All registers are cleared.
- **DEEP\_SLEEP:** Only RTC is powered on - the rest of the chip is powered off. Recovery memory of RTC can keep basic WiFi connecting information.
- **SLEEP:** Only the RTC is operating. The crystal oscillator is disabled. Any wakeup events (MAC, host, RTC timer, external interrupts) will put the chip into the WAKEUP state.
- **WAKEUP:** In this state, the system goes from the sleep states to the PWR state. The crystal oscillator and PLLs are enabled.
- **ON:** the high speed clock is operational and sent to each block enabled by the clock control register. Lower level clock gating is implemented at the block level, including the CPU, which can be gated off using the WAITI instruction, while the system is on.





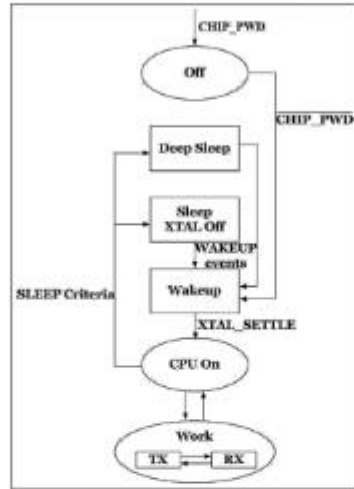

Figure 3 Illustration of Power Management

## 6. Clock Management

### 6.1. High Frequency Clock

The high frequency clock on ESP8266EX is used to drive both transmit and receive mixers. This clock is generated from the internal crystal oscillator and an external crystal. The crystal frequency can range from 26MHz to 52MHz.

While internal calibration of the crystal oscillator ensures that a wide range of crystals can be used, in general, the quality of the crystal is still a factor to consider, to have reasonable phase noise that is required for good performance. When the crystal selected is sub-optimal due to large frequency drifts or poor Q-factor, the maximum throughput and sensitivity of the WiFi system is degraded. Please refer to the application notes on how the frequency offset can be measured.





Table 18 High Frequency Clock

Parameter	Symbol	Min	Max	Unit
Frequency	FXO	26	52	MHz
Loading capacitance	CL		32	pF
Motional capacitance	CM	2	5	pF
Series resistance	RS	0	65	$\Omega$
Frequency tolerance	$\Delta$ FXO	-15	15	ppm
Frequency vs temperature (-25°C - 75°C)	$\Delta$ FXO,Temp	-15	15	ppm

## 6.2. External Reference Requirements

For an externally generated clock, the frequency can range from 26MHz to 52MHz can be used. For good performance of the radio, the following characteristics are expected of the clock:

Table 19 External Clock Reference

Parameter	Symbol	Min	Max	Unit
Clock amplitude	VXO	0.2	1	Vpp
External clock accuracy	$\Delta$ FXO_EXT	-15	15	ppm
Phase noise @1kHz offset, 40MHz clock			-120	dBc/Hz
Phase noise @10kHz offset, 40MHz clock			-130	dBc/Hz
Phase noise @100kHz offset, 40MHz clock			-138	dBc/Hz

## 7. Radio

The ESP8266EX radio consists of the following main blocks:

- 2.4GHz receiver
- 2.4GHz transmitter
- High speed clock generators and crystal oscillator
- Real time clock
- Bias and regulators
- Power management





### 7.1. Channel Frequencies

The RF transceiver supports the following channels according to the IEEE802.11b/g/n standards.

Table 20 Frequency Channel

Channel No	Frequency (MHz)	Channel No	Frequency (MHz)
1	2412	8	2447
2	2417	9	2452
3	2422	10	2457
4	2427	11	2462
5	2432	12	2467
6	2437	13	2472
7	2442	14	2484

### 7.2. 2.4 GHz Receiver

The 2.4GHz receiver downconverts the RF signal to quadrature baseband signals and converts them to the digital domain with 2 high resolution high speed ADCs. To adapt to varying signal channel conditions, RF filters, automatic gain control (AGC), DC offset cancelation circuits and baseband filters are integrated within ESP8266EX.

### 7.3. 2.4 GHz Transmitter

The 2.4GHz transmitter up-converts the quadrature baseband signals to 2.4GHz, and drives the antenna with a high powered CMOS power amplifier. The use of digital calibration further improves the linearity of the power amplifier, enabling a state of art performance of delivering +19.5dBm average power for 802.11b transmission and +16dBm for 802.11n transmission.

Additional calibrations are integrated to cancel any imperfections of the radio, such as:

- carrier leakage,
- I/Q phase matching, and
- baseband nonlinearities

This reduces the amount of time required and test equipment required for production testing.

### 7.4. Clock Generator

The clock generator generates quadrature 2.4 GHz clock signals for the receiver and transmitter. All components of the clock generator are integrated on-chip, including:







- inductor,
- varactor, and
- loop filter

The clock generator has built-in calibration and self test circuits. Quadrature clock phases and phase noise are optimized on-chip with patented calibration algorithms to ensure the best receiver and transmitter performance.

**8. Appendix: QFN32 Package Size**

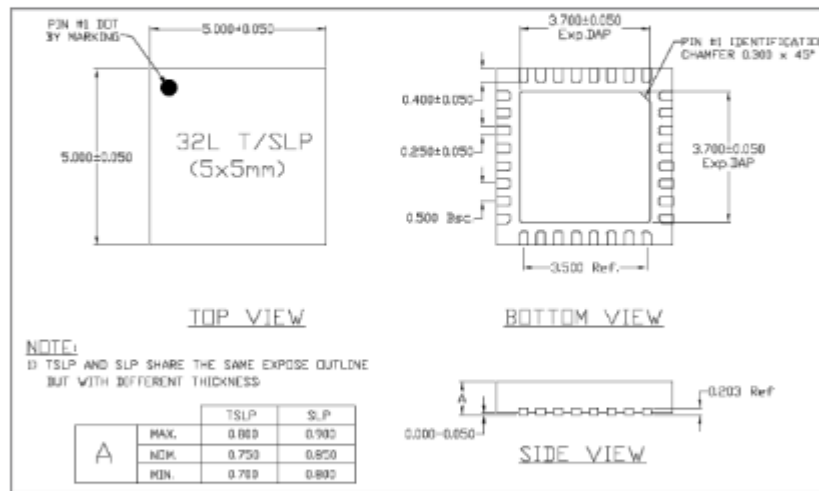

data sheet

**system:** Lithium-Ion-Battery  
**nominal voltage:** 3,7V  
**end charge voltage:** 4,2V  
**max. charge current:** 500mA  
**charge conditions:**  
 standard charge: 250mA for 3,5h min.  
 fast charge: 500mA for 2,5h min.  
 charging method: CC-CV (constant current and constant voltage)  
**capacity:** after standard charge  
 nominal: 500mAh at 0,2C discharge to 2,75V  
 minimal: 450mAh at 0,2C discharge  
 400mAh at 1C discharge  
**max. discharge current:** 500mA  
**life time expectancy:** > 300 cycles  
**ambient temperature range:**  
 charge: 0...45°C  
 discharge: -20...60°C  
 long term storage: -20...35°C (less than 1 year)  
**weight:** 19g  
**dimensions:** L1: 53,0mm  
 L2: 34,1mm  
 h1: 4,8mm

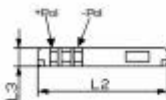
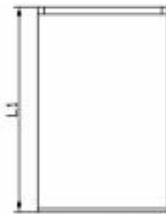

specifications for model/type:	A – Nok3 (Nokia BL-4C)
Anemmann drawing number / part number:	5060063
drawn by / date:	Gramlich / 12.07.2005

Manufacturer reserves the right to alter or amend the design, model and specification without prior notice

