

## BAB IV HASIL DAN PEMBAHASAN

### 4.1. Data Teknik Bangunan pada Bendung Batang Asai Kabupaten Sarolangun Provinsi Jambi

Data teknis bangunan berdasarkan laporan *Detail Engineering Design* (DED) PT.

Daya Cipta Dian Rancana adalah sebagai berikut :

a) Elevasi Puncak Bendung	= + 62,00 m
b) Elevasi Bangunan Penguras	= + 60,00 m
c) Elevasi Lantai Olak	= + 56,00 m
d) Elevasi Muka Air Banjir (MAB) Hulu	= + 66,07 m
e) Elevasi Muka Air Banjir (MAB) Hilir	= + 62,41 m
f) Elevasi Muka Air Normal (MAN) Hulu	= + 65,70 m
g) Elevasi Muka Air Normal (MAN) Hilir	= + 58,00 m
h) Jumlah Pintu pada Bendung Gerak	= 7 pintu
Lebar Pintu Pada Bendung Gerak	= 12,50 m
i) Jumlah Pintu pada Bangunan Penguras	= 3 pintu
Lebar Pintu pada Bangunan Penguras	= 5,00 m
j) Jumlah Pilar	= 9 pilar
Lebar Pilar	= 2,50 m
k) Berat Rumah Operasi dan Jembatan Pelayanan	= 59,750 ton
l) Berat Jembatan Kendaraan	= 117,347 ton
m) Berat Pintu	= 99,870 ton

Gambar denah bendung serta potongan bendung gerak dan bangunan penguras dapat dilihat pada Gambar 4.1 sampai dengan Gambar 4.7.

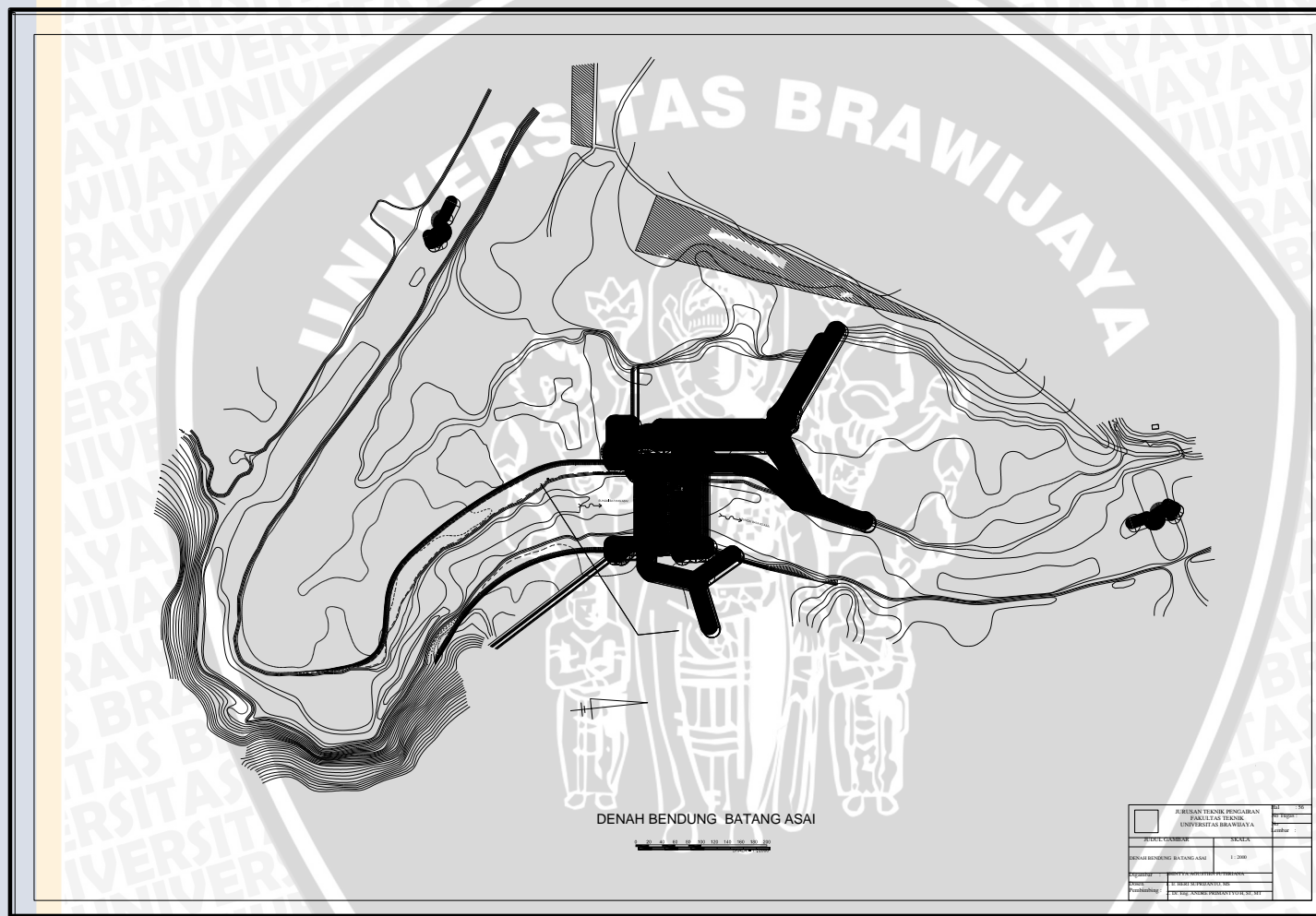

Gambar 4.1. Denah Bendung Batang Asai

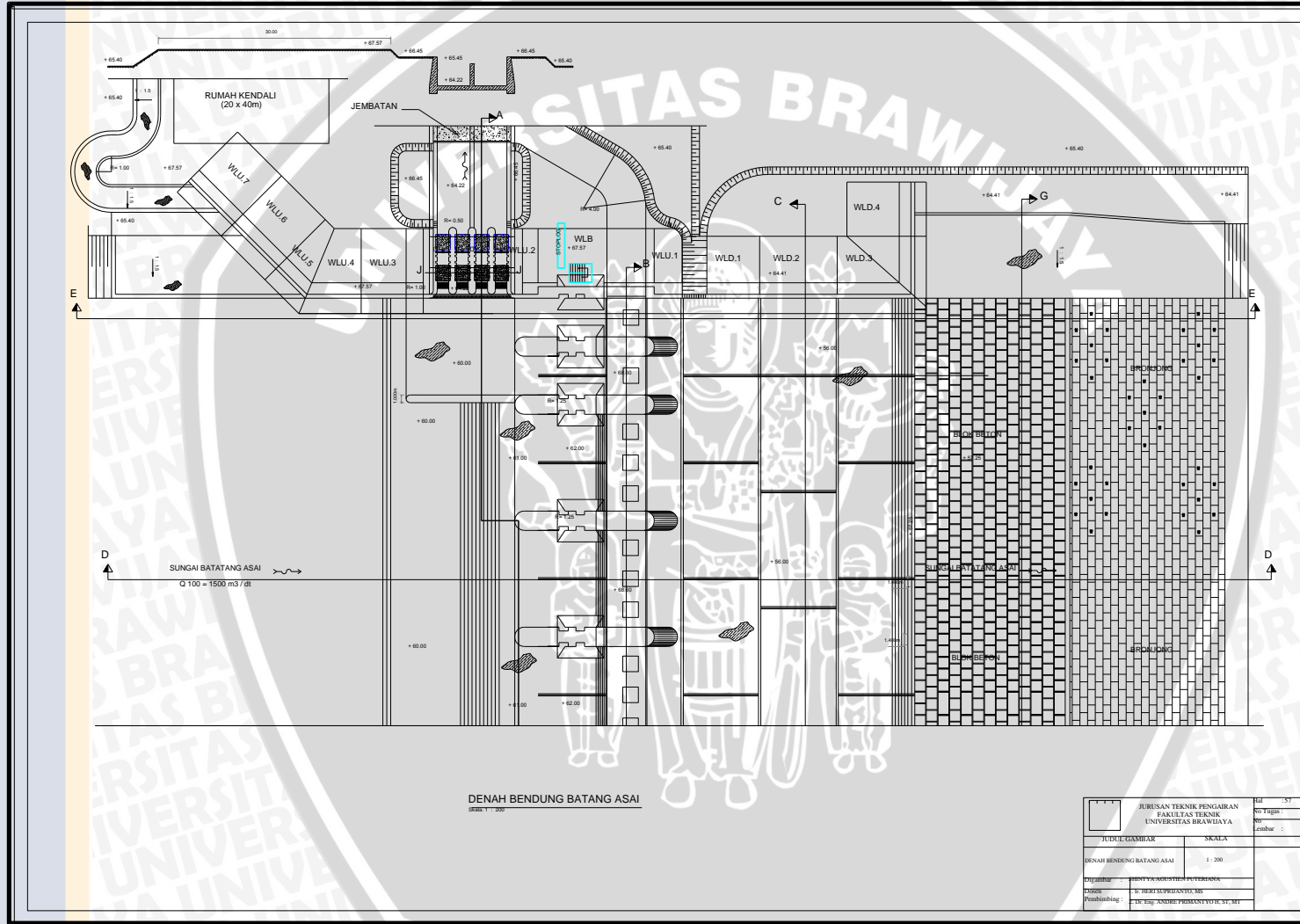

Gambar 4.2. Denah Bendung Batang Asai

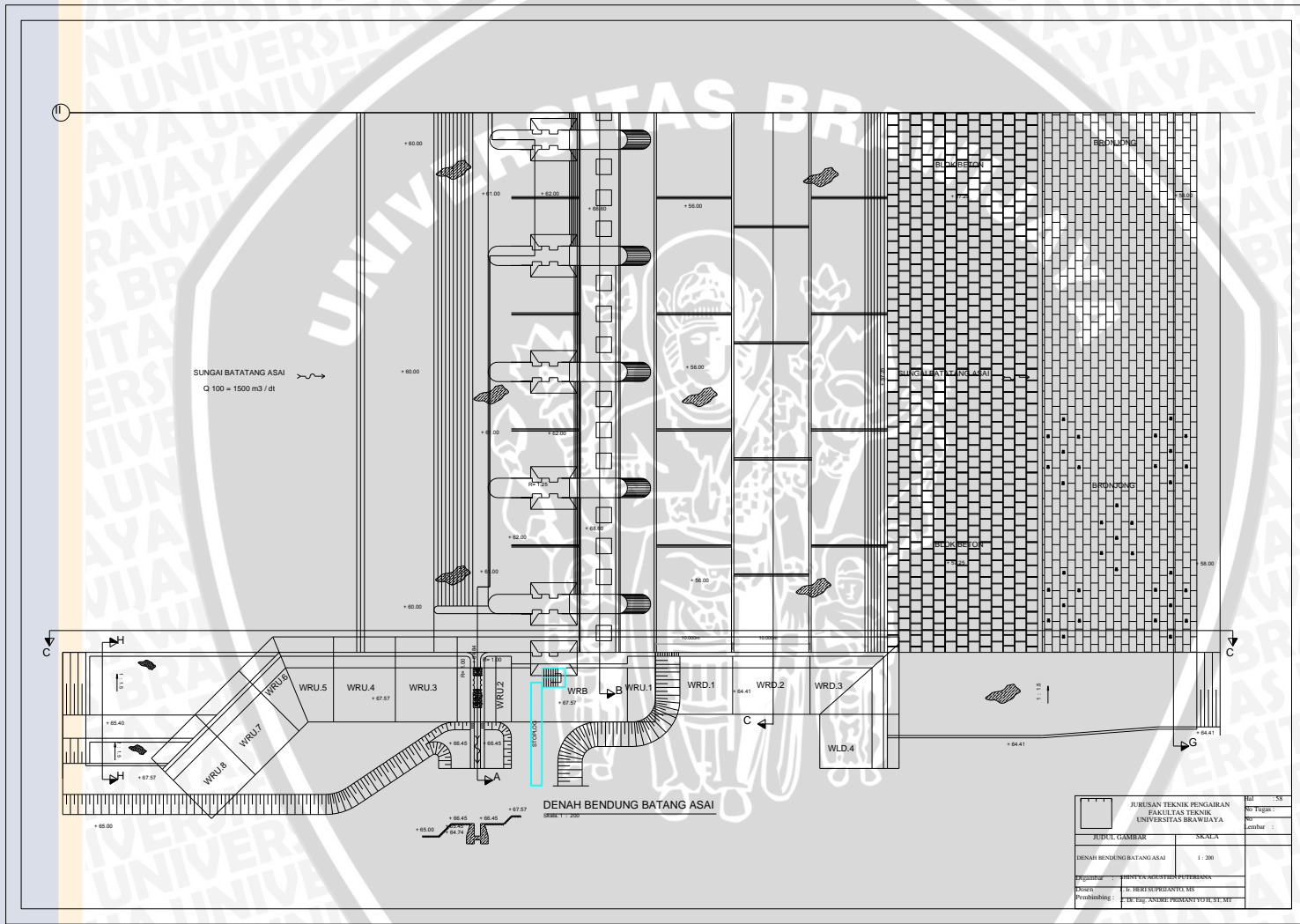

Gambar 4.3. Denah Bendung Batang Asai

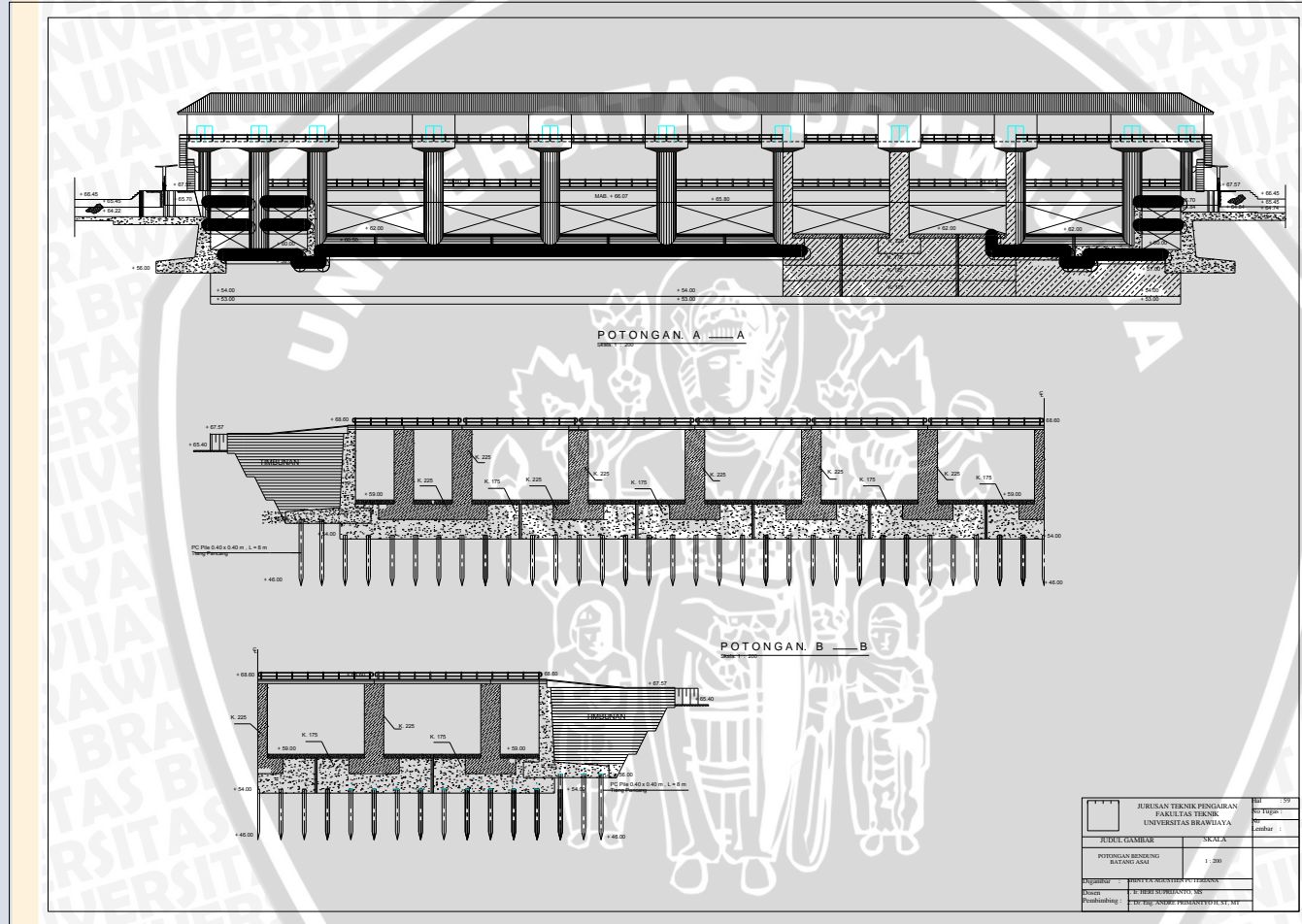

Gambar 4.4. Potongan Bendung Batang Asai

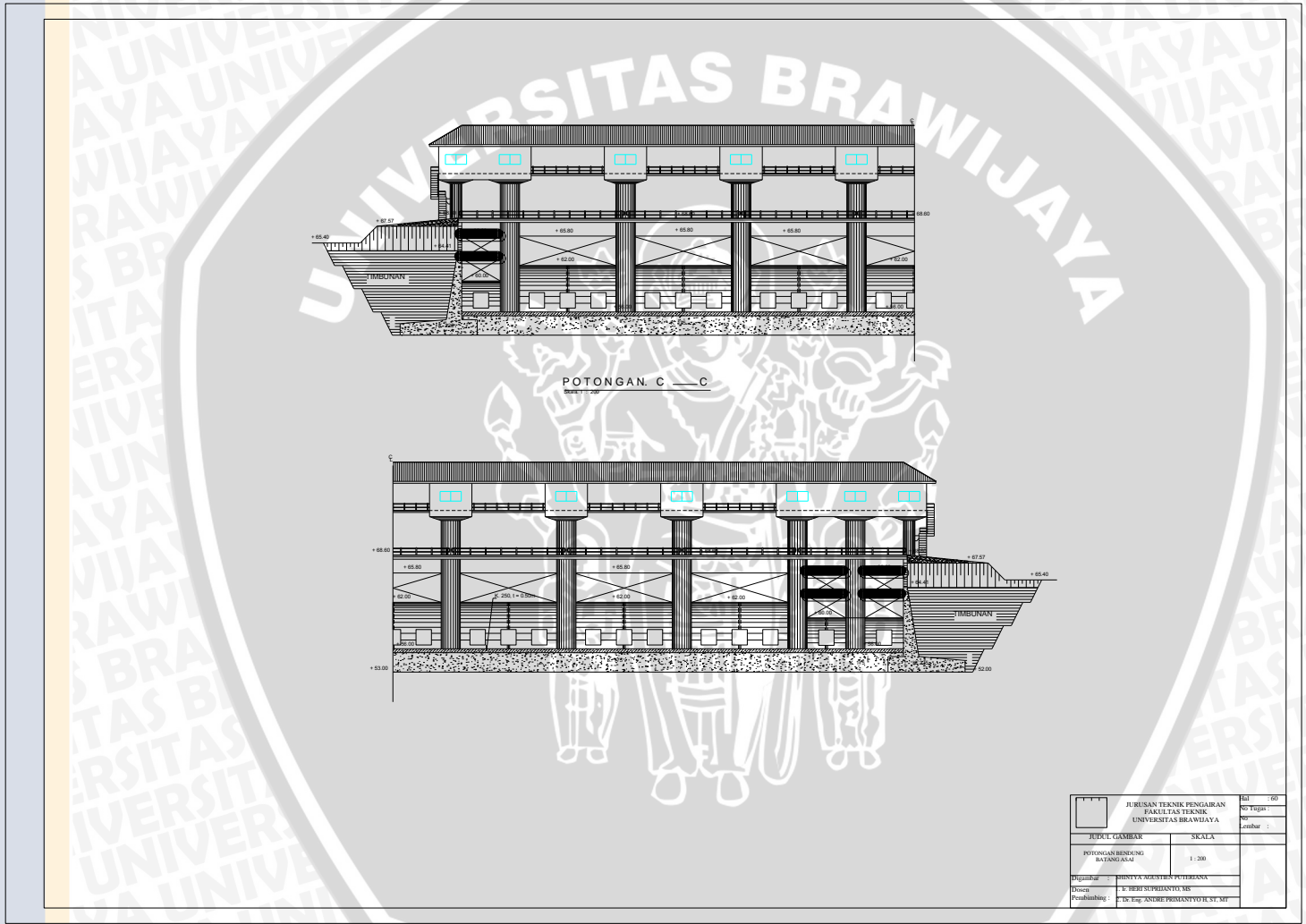

Gambar 4.5. Potongan Bendung Batang Asai

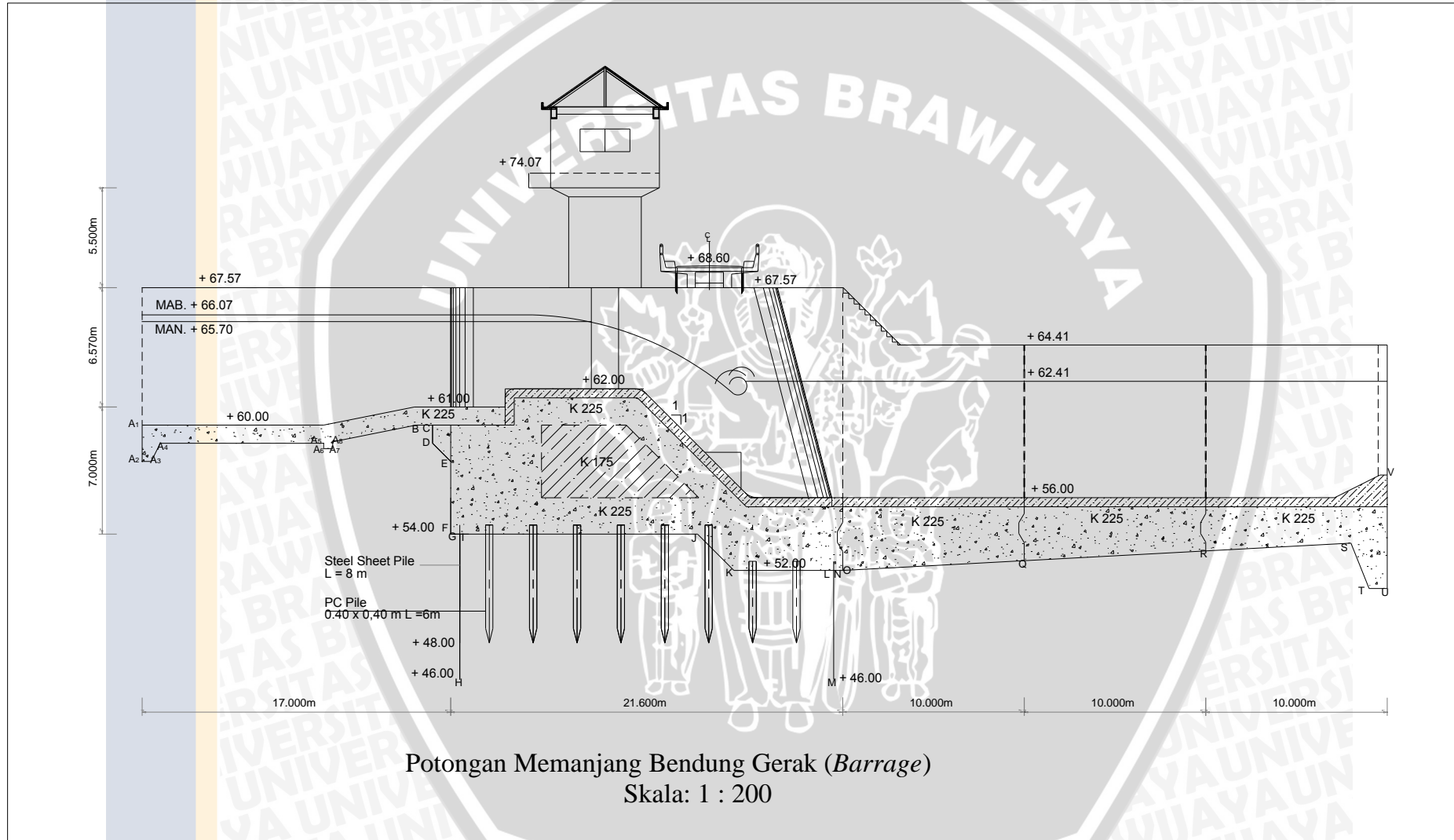

Gambar 4.6. Potongan Memanjang Bendung Gerak (Barrage)

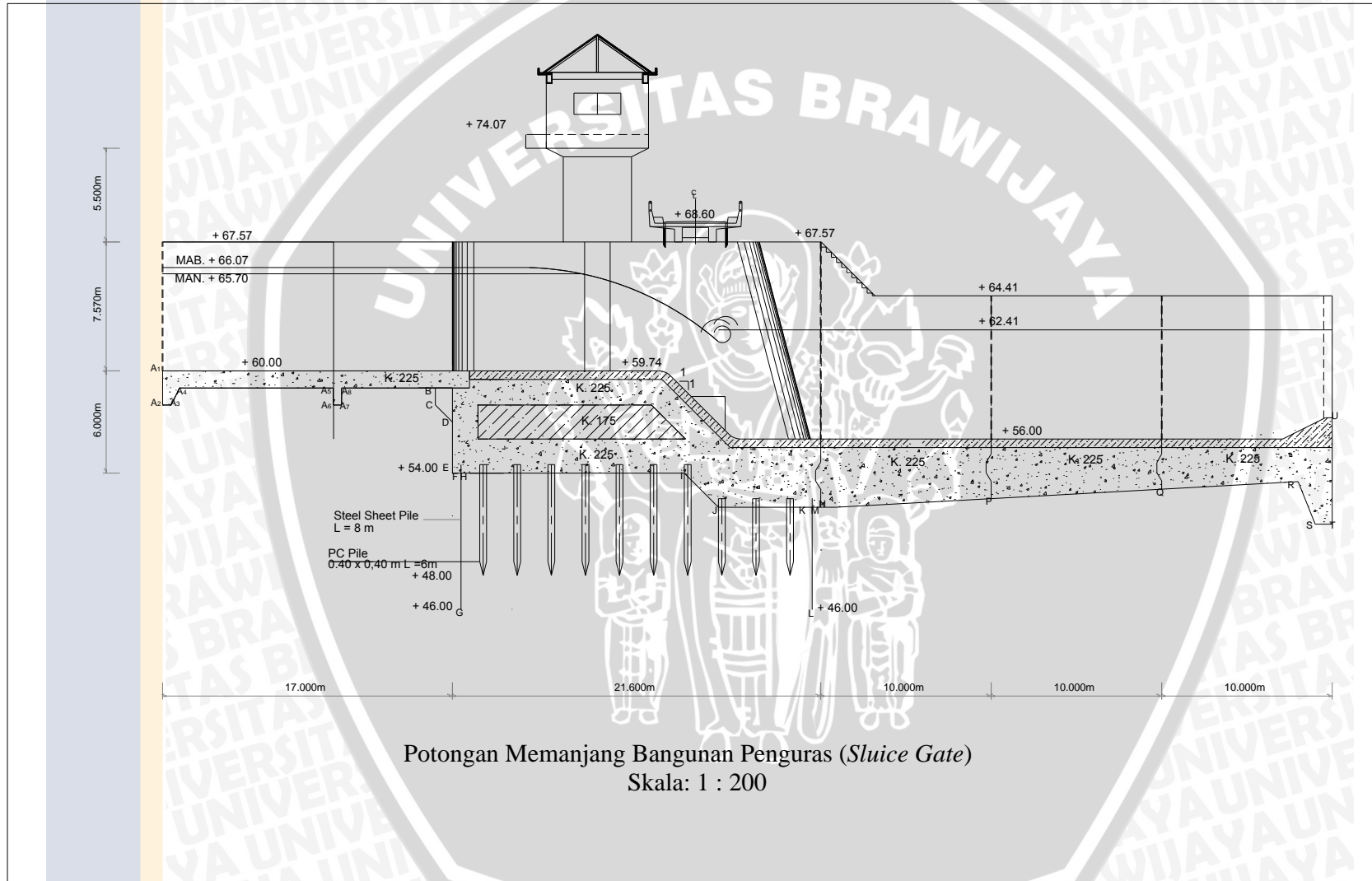

**Gambar 4.7. Potongan Memanjang Bangunan Penguras (Sluice Gate)**



## 4.2. Analisis Daya Dukung Tanah

Analisis daya dukung tanah mempelajari kemampuan tanah dalam mendukung beban pondasi yang bekerja di atasnya. Pondasi adalah bagian dari struktur yang berfungsi meneruskan beban akibat berat struktur yang berfungsi meneruskan beban akibat berat struktur secara langsung ke tanah yang terletak di bawahnya. Perancangan yang seksama diperlukan agar beban pondasi tidak mengakibatkan timbulnya tekanan yang berlebihan ke tanah di bawahnya, karena tekanan yang berlebihan dapat mengakibatkan keruntuhan pondasi.

### 4.2.1. Daya Dukung Tanah pada Bendung Gerak (*Barrage*)

Kapasitas daya dukung pada daerah studi ini yang didapatkan dari hasil pengujian lapangan yaitu menggunakan hasil uji *Standart Penetration Test* (SPT) yang dilakukan oleh konsultan perencana. Data *bor log* terdapat pada Tabel 3.1.

Dengan melihat hasil *bor log* yang mana jenis tanah yang akan digunakan sebagai pondasi pada konstruksi bendung gerak (*barrage*) yaitu berupa batu lanau, lempungan, abu-abu kehijauan, padat. Pondasi terletak pada elevasi +54,00 m dengan nilai N-SPT terendah atau paling kritis yaitu 31. Menurut Hary Christady Hardiyatmo (Teknik Fondasi 1) dengan melihat nilai N-SPT antara 30 – 50 memiliki jenis tanah berupa tanah padat.

Perhitungan daya dukung izin tanah berdasarkan data SPT adalah:

Apabila tanah mengandung pasir halus atau pasir berlanau yang terletak di bawah muka air tanah, maka sebelum N digunakan dalam hitungan kapasitas daya dukung, nilai N harus direduksi sesuai dengan persamaan (2-9).

$$\begin{aligned} N_{\text{Koreksi}} &= 15 + \frac{1}{2} (N - 15) \\ &= 15 + \frac{1}{2} (31 - 15) \\ &= 23,00 \end{aligned}$$

Menurut Punmia (1973), mengusulkan persamaan kapasitas dukung izin neto yang dikaitkan dengan nilai SPT dan sekaligus bergantung pada faktor kedalaman pondasi dapat dihitung menggunakan persamaan (2-8) sebagai berikut:

$$\begin{aligned} q_a &= 3,5 \cdot (N-3) \left( \frac{B+0,3}{2B} \right)^2 R_{w2} \cdot R_d \\ q_a &= 3,5 \cdot (N-3) \left( \frac{B+0,3}{2B} \right)^2 R_{w2} \cdot \left( 1 + \frac{D}{B} \right) \\ q_a &= 3,5 \cdot (23,00 - 3) \left( \frac{21,60+0,3}{2 \cdot (21,60)} \right)^2 0,5 \cdot \left( 1 + \frac{8,00}{21,60} \right) \\ &= 12,33 \text{ t/m}^2 \end{aligned}$$

#### 4.2.2. Daya Dukung Tanah pada Bangunan Penguras (*Sluice Gate*)

Daya dukung izin tanah dapat dihitung menggunakan persamaan (2-8) sebagai berikut:

$$q_a = 3,5 \cdot (N-3) \left( \frac{B+0,3}{2B} \right)^2 R_{w2} \cdot R_d$$

$$q_a = 3,5 \cdot (N-3) \left( \frac{B+0,3}{2B} \right)^2 R_{w2} \cdot \left( 1 + \frac{D}{B} \right)$$

$$q_a = 3,5 \cdot (23,00 - 3) \left( \frac{21,60+0,3}{2 \cdot (21,60)} \right)^2 0,5 \cdot \left( 1 + \frac{6,00}{21,60} \right)$$

$$= 11,49 \text{ t/m}^2$$

#### 4.2.3. Daya Dukung Tanah pada Dinding Penahan Tanah Bagian Hulu

Dengan melihat hasil bor pada Tabel.3.1. yang mana jenis tanah yang akan digunakan sebagai pondasi pada konstruksi dinding penahan tanah bagian hulu yaitu pasir gravel, abu-abu coklat dan sedang. Pondasi terletak pada elevasi +56,00 m dengan nilai N-SPT adalah 49.

Apabila tanah mengandung pasir halus atau pasir berlanau yang terletak di bawah muka air tanah, maka sebelum N digunakan dalam hitungan kapasitas daya dukung, nilai N harus direduksi sesuai dengan persamaan (2-9).

$$N_{\text{Koreksi}} = 15 + \frac{1}{2} (N' - 15)$$

$$= 15 + \frac{1}{2} (49 - 15)$$

$$= 32,00$$

Daya dukung izin tanah dapat dihitung menggunakan persamaan (2-8) sebagai berikut:

$$q_a = 3,5 \cdot (N-3) \left( \frac{B+0,3}{2B} \right)^2 R_{w2} \cdot R_d$$

$$q_a = 3,5 \cdot (N-3) \left( \frac{B+0,3}{2B} \right)^2 R_{w2} \cdot \left( 1 + \frac{D}{B} \right)$$

$$q_a = 3,5 \cdot (32 - 3) \left( \frac{11,00+0,3}{2 \cdot (11,00)} \right)^2 0,5 \cdot \left( 1 + \frac{4,00}{11,00} \right)$$

$$= 18,26 \text{ t/m}^2$$

#### 4.2.4. Daya Dukung Tanah pada Dinding Penahan Tanah Bagian Jembatan

Daya dukung izin tanah dapat dihitung menggunakan persamaan (2-8) sebagai berikut:

$$q_a = 3,5 \cdot (N-3) \left( \frac{B+0,3}{2B} \right)^2 R_{w2} \cdot R_d$$

$$q_a = 3,5 \cdot (N-3) \left( \frac{B+0,3}{2B} \right)^2 R_{w2} \cdot \left( 1 + \frac{D}{B} \right)$$

$$q_a = 3,5 \cdot (32,00 - 3) \left( \frac{11,00 + 0,3}{2 \cdot (11,00)} \right)^2 \cdot 0,5 \cdot \left( 1 + \frac{4,00}{11,00} \right)$$

$$= 18,26 \text{ t/m}^2$$

#### 4.2.5. Daya Dukung Tanah pada Dinding Penahan Tanah Bagian Hilir

Dengan melihat hasil bor pada Tabel.3.1. yang mana jenis tanah yang akan digunakan sebagai pondasi pada konstruksi dinding penahan tanah bagian hilir yaitu berupa batu lanau, lempungan, abu-abu, padat dan keras. Pondasi terletak pada elevasi +52,00 m dengan nilai N-SPT adalah 39.

Apabila tanah mengandung pasir halus atau pasir berlanau yang terletak di bawah muka air tanah, maka sebelum N digunakan dalam hitungan kapasitas daya dukung, nilai N harus direduksi sesuai dengan persamaan (2-9).

$$N_{\text{Koreksi}} = 15 + \frac{1}{2} (N' - 15)$$

$$= 15 + \frac{1}{2} (39 - 15)$$

$$= 27,00$$

Daya dukung izin tanah dapat dihitung menggunakan persamaan (2-8) sebagai berikut:

$$q_a = 3,5 \cdot (N - 3) \left( \frac{B + 0,3}{2B} \right)^2 R_{w2} \cdot R_d$$

$$q_a = 3,5 \cdot (N - 3) \left( \frac{B + 0,3}{2B} \right)^2 R_{w2} \cdot \left( 1 + \frac{D}{B} \right)$$

$$q_a = 3,5 \cdot (27,00 - 3) \left( \frac{10,00 + 0,3}{2 \cdot (10,00)} \right)^2 \cdot 0,5 \cdot \left( 1 + \frac{4,00}{11,00} \right)$$

$$= 15,59 \text{ t/m}^2$$

#### 4.3. Analisis Pembebanan dan Stabilitas Konstruksi

Konstruksi bangunan memiliki pembebanan yang berbeda, baik itu berupa bentuk, kondisi maupun kegunaan dari konstruksi tersebut. Pembebanan tiap konstruksi perlu dianalisis sesuai dengan yang terjadi di lapangan.

Perhitungan stabilitas bangunan dilakukan dengan kondisi gaya-gaya yang bekerja pada bangunan tersebut. Pembebanan yang bekerja pada bendung gerak, bangunan penguras dan dinding penahan dihitung dengan berbagai kondisi.

##### 4.3.1. Bendung Gerak (*Barrage*)

Dalam perencanaan stabilitas konstruksi bangunan perlu dilakukan anggapan atau asumsi keadaan tanpa gempa dan gempa. Adapun setiap keadaan tersebut, bangunan bendung gerak (*barrage*) masih perlu diadakan tinjauan dengan 4 kondisi yaitu :

1. Kondisi I : saat muka air normal (tanpa gempa)
2. Kondisi II : saat muka air normal (gempa)
3. Kondisi III : saat muka air banjir  $Q_{PMF}$  (tanpa gempa)
4. Kondisi IV : saat muka air banjir  $Q_{PMF}$  (gempa)

Perhitungan stabilitas bendung gerak (*barrage*) dilakukan dengan kondisi gaya. Pembebanan yang bekerja pada bendung gerak (*barrage*) adalah sebagai berikut:

1. Beban vertikal
  - a) Gaya berat dari bendung gerak (*barrage*) dan pintu air.
  - b) Pilar (jembatan kendaraan, rumah operasi dan jembatan pelayanan)
2. Tekanan air (statis dan dinamis)
3. Tekanan tanah (aktif dan pasif)
4. Gaya angkat (*uplift*)

Beberapa perhitungan stabilitas pada bendung gerak (*barrage*) dalam keadaan muka air normal dan muka air banjir ( $Q_{PMF}$ ) dijabarkan pembebanannya untuk mengetahui beban-beban apa saja yang terjadi pada bangunan

Gaya berat dari bendung gerak (*barrage*) disesuaikan dengan dimensi dari bangunan tersebut. Untuk mempermudah dalam menganalisis perhitungan stabilitas pada bendung gerak (*barrage*) ini dilakukan dengan menganalisis per panel, dapat dilihat pada Gambar 4.8. Sedangkan untuk mempermudah dalam perhitungan beban vertikal maka bangunan perlu dibagi menjadi bagian-bagian kecil yang disajikan secara visual seperti pada Gambar 4.9. Perhitungan gaya berat pada bendung gerak (*barrage*) menggunakan persamaan (2-12) dapat dilihat pada Tabel 4.1.

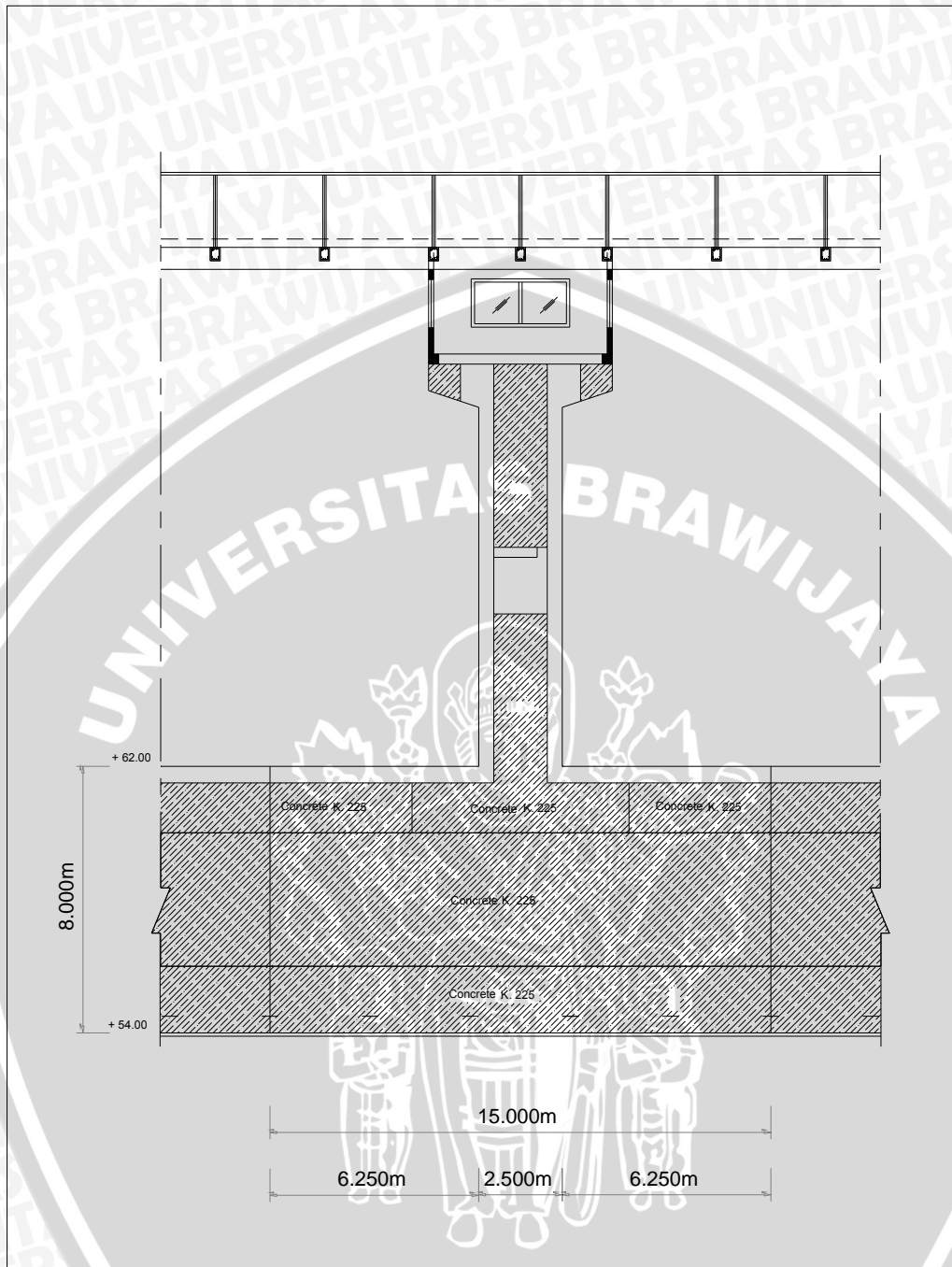

Gambar 4.8. Potongan Melintang Bendung Gerak (*Barrage*) per Satu Panel

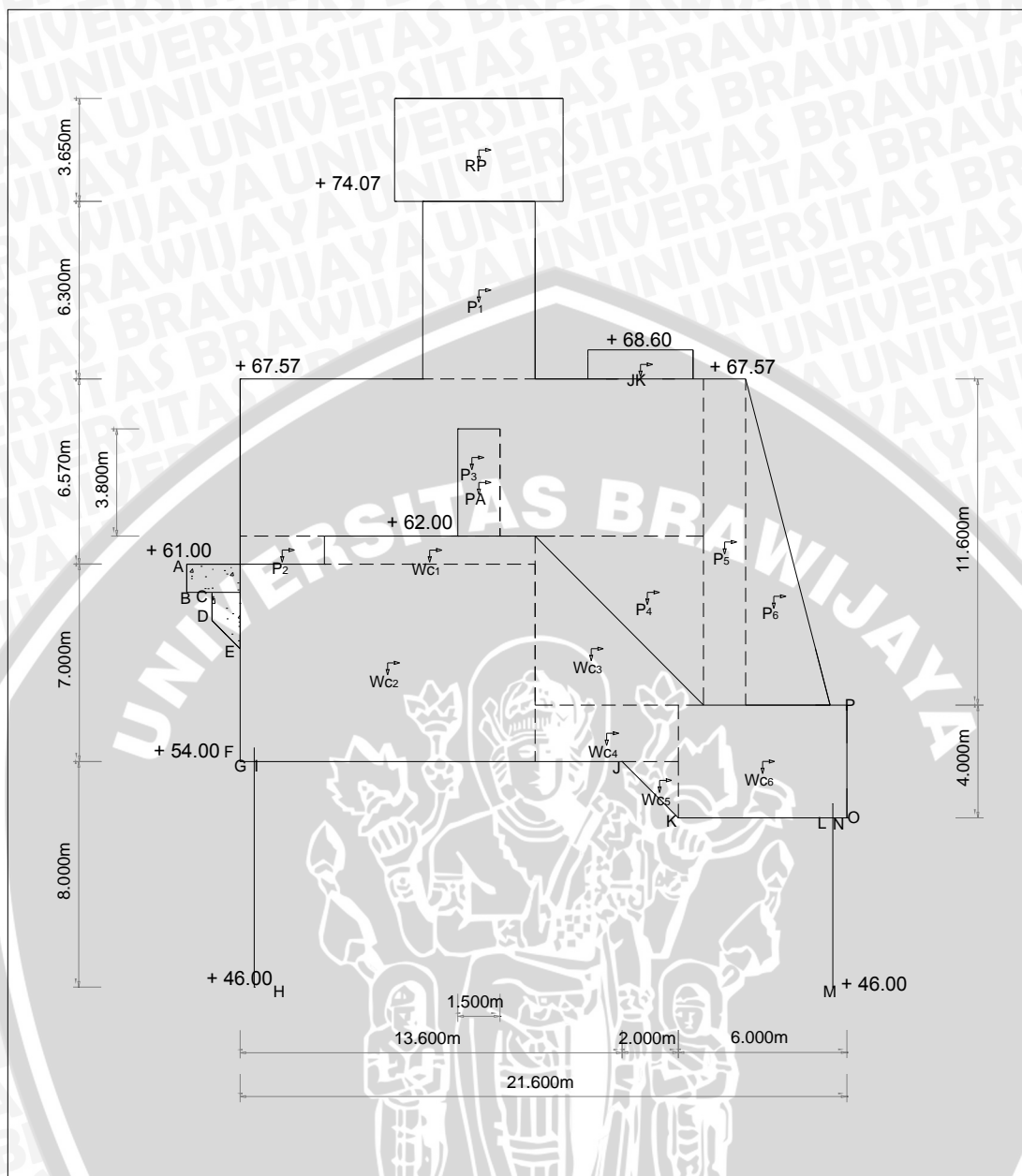

Gambar 4.9. Gaya Berat pada Bendung Gerak (Barrage)

Tabel 4.1. Perhitungan Gaya Berat pada Bendung Gerak (*Barrage*)

Notasi	Nilai				Volume	$\gamma$	Gaya Berat
	Lebar	Tinggi	Panjang	Ratio			
	[ 1 ]	[ 2 ]	[ 3 ]	[ 4 ]	$m^3$	( $t/m^3$ )	(t)
Wc1	7,500	1,000	15,000	1,000	112,500	2,400	270,000
Wc2	10,500	7,000	15,000	1,000	1102,500	2,400	2646,000
Wc3	5,997	5,997	15,000	0,500	269,730	2,400	647,352
Wc4	5,100	2,003	15,000	1,000	153,230	2,400	367,751
Wc5	2,000	2,000	15,000	0,500	30,000	2,400	72,000
Wc6	6,000	4,003	15,000	1,000	360,270	2,400	864,648
P1	4,000	6,300	2,500	1,000	63,000	2,400	151,200
P2	3,000	1,000	2,500	1,000	7,500	2,400	18,000
P3	16,497	5,570	2,500	1,000	229,721	2,400	551,330
P4	5,997	5,997	2,500	0,500	44,955	2,400	107,892
P5	1,503	11,567	2,500	1,000	43,463	2,400	104,311
P6	3,000	11,567	2,500	0,500	43,376	2,400	104,103
PA							99,840
RP							59,750
JK							117,347
Total							6181,524

Sumber: Hasil Perhitungan

Keterangan:

[ 1 ] = lebar tiap bagian (m)

[ 2 ] = tinggi tiap bagian (m)

[ 3 ] = panjang konstruksi, tiap 15 meter panjang (m)

[ 4 ] = 1 digunakan untuk penampang persegi atau persegi panjang  
= 0,5 digunakan untuk penampang segitiga

[ 5 ] = volume ( $m^3$ )

$$= [ 1 ] * [ 2 ] * [ 3 ] * [ 4 ]$$

[ 6 ] = berat jenis beton bertulang = 2,400 ( $t/m^3$ )

[ 7 ] = gaya berat konstruksi (ton)

$$= [ 5 ] * [ 6 ]$$

Gaya berat yang dipengaruhi oleh gempa dapat menimbulkan gaya yang bekerja ke arah horizontal. Besarnya gaya horizontal ini didapatkan dengan cara perkalian antara berat vertikal dengan koefisien gempa, dimana nilai koefisien gempa pada daerah studi ini adalah 0,15.

Berat air menimbulkan gaya yang bekerja ke arah vertikal dimana volume air yang ada dikalikan dengan berat jenis air. Gaya berat air ini berpengaruh terhadap pembebanan pada bendung gerak (*barrage*). Salah satu gaya berat yang terdapat pada kondisi tersebut adalah sebagai berikut:

$$\begin{aligned} W_{w1} &= \text{lebar} \times \text{tinggi} \times \text{panjang} \times \text{ratio} \times \gamma_w \\ &= 3,000 \times 1,000 \times 15,000 \times 1,000 \times 1,000 \\ &= 45,000 \text{ ton} \end{aligned}$$

Tekanan air menimbulkan gaya horizontal yang berpengaruh terhadap pembebanan bendung gerak (*barrage*). Salah satu tekanan air yang terdapat pada kondisi tersebut adalah sebagai berikut:

$$\begin{aligned} P_{w1} &= \frac{1}{2} \cdot H^2 \times \text{panjang} \times \gamma_w \\ &= \frac{1}{2} \times (5,700)^2 \times 15,000 \times 0,500 \\ &= 243,675 \text{ ton} \end{aligned}$$

Tekanan tanah yang dialami oleh bangunan berupa tekanan tanah aktif dan tekanan tanah pasif. Dimana koefisien tekanan tanah aktif dan pasif dihitung menggunakan persamaan berikut:

Tekanan tanah aktif kondisi normal:

$$\begin{aligned} K_a &= \sin \left( \frac{1 - \sin \phi}{1 + \sin \phi} \right) \\ &= \sin \left( \frac{1 - \sin 27,50}{1 + \sin 27,50} \right) \\ &= 0,368 \\ K_{ea} &= \sin \left( \frac{1 - \sin \phi}{1 + \sin \phi} \right) \cdot (1 - kv) \\ &= \sin \left( \frac{1 - \sin 27,50}{1 + \sin 27,50} \right) \cdot (1 - 0) \\ &= 0,368 \end{aligned}$$

Tekanan tanah pasif:

$$\begin{aligned} K_p &= \sin \left( \frac{1 + \sin \phi}{1 - \sin \phi} \right) \\ &= \sin \left( \frac{1 + \sin 27,50}{1 - \sin 27,50} \right) \\ &= 2,716 \end{aligned}$$



$$\begin{aligned}
 K_{ep} &= \sin \left( \frac{1 + \sin \phi}{1 - \sin \phi} \right) \cdot (1 - k_v) \\
 &= \sin \left( \frac{1 + \sin 27,50}{1 - \sin 27,50} \right) \cdot (1 - 0) \\
 &= 2,716
 \end{aligned}$$

Perhitungan tekanan tanah aktif adalah sebagai berikut:

$$\begin{aligned}
 P_a &= \frac{1}{2} \cdot K_a \cdot \gamma_{\text{sub}} \cdot H^2 \cdot \text{Panjang} \\
 &= \frac{1}{2} \cdot 0,368 \cdot 0,976 \cdot (8,000)^2 \cdot (15,000) \\
 &= 172,589 \text{ ton}
 \end{aligned}$$

Perhitungan tekanan tanah pasif adalah sebagai berikut:

$$\begin{aligned}
 P_p &= \frac{1}{2} \cdot K_p \cdot \gamma_{\text{sub}} \cdot H^2 \cdot \text{Panjang} \\
 &= \frac{1}{2} \cdot 2,716 \cdot 0,976 \cdot (4,000)^2 \cdot (15,000) \\
 &= -318,698 \text{ ton,}
 \end{aligned}$$

Gaya angkat (*uplift*) terjadi disebabkan oleh perbedaan elevasi muka air hulu dan hilir yang bekerja pada dasar pondasi. Bangunan yang terendam air akan mendapatkan gaya angkat ke atas yang akan mengurangi berat efektif bangunan itu sendiri. Perhitungan gaya angkat (*uplift*) adalah sebagai berikut:

$$\begin{aligned}
 P_{u1} &= \text{lebar} \times \text{tinggi uplift} \times \text{panjang} \times \gamma_{\text{air}} \\
 &= 0,500 \times 9,984 \times 15,000 \times 1,000 \\
 &= -74,877 \text{ ton}
 \end{aligned}$$

Perhitungan uplift pada kondisi normal maupun pada kondisi banjir disajikan pada Tabel 4.2 dan 4.3.

Analisis stabilitas konstruksi untuk kondisi normal dapat dilihat dari nilai stabilitas geser, stabilitas guling, eksentrisitas dan daya dukung. Perhitungan nilai eksentrisitas sesuai dengan persamaan (2-4) dan perhitungan daya dukung adalah sebagai berikut:

1. Stabilitas terhadap Guling:

$$\begin{aligned}
 SF &= \frac{M_v}{M_h} \\
 &= \frac{53589,574}{6146,088} \\
 &= 8,72
 \end{aligned}$$

Syarat stabilitas terhadap guling:

$$\begin{aligned}
 SF &> 1,5 \quad (\text{SF dalam keadaan normal}) \\
 \text{maka, } 8,72 &> 1,5 \quad \text{..... memenuhi syarat}
 \end{aligned}$$

## 2. Stabilitas terhadap Geser:

Dengan:  $f = 0,7$

$$\begin{aligned} SF &= \frac{\sum V \cdot f}{\sum H} \\ &= \frac{4177,317 \cdot 0,7}{894,745} \\ &= 3,27 \end{aligned}$$

Syarat stabilitas terhadap guling:

$$SF > 1,5 \quad (\text{SF dalam keadaan gempa})$$

maka  $3,27 > 1,5$  ..... memenuhi syarat

## 3. Nilai eksentrisitas:

$$\begin{aligned} e &= \left| \frac{\sum M_v - \sum M_h}{\sum V} - \frac{B}{2} \right| \\ &= \left| \frac{53589,574 - 6164,008}{4177,317} - \frac{21,60}{2} \right| \\ &= 0,56 \end{aligned}$$

Syarat eksentrisitas:

$$e \leq \frac{B}{6}$$

$$\text{maka, } e \leq \frac{21,600}{6}$$

$$0,56 \leq 3,60 \quad \text{..... memenuhi syarat}$$

## 4. Daya Dukung:

$$\begin{aligned} \sigma_{\max} &= \frac{\sum V}{A} \left( 1 + \frac{6 \cdot e}{B} \right) \\ &= \frac{4177,317}{21,600 \times 15} \left( 1 + \frac{6 \cdot 0,56}{21,600} \right) \\ &= 14,89 \text{ t/m}^2 \\ \sigma_{\min} &= \frac{\sum V}{A} \left( 1 - \frac{6 \cdot e}{B} \right) \\ &= \frac{4177,317}{21,600 \times 15} \left( 1 - \frac{6 \cdot 0,56}{21,600} \right) \\ &= 10,90 \text{ t/m}^2 \end{aligned}$$

Syarat daya dukung:

$$\sigma_{\max} \text{ dan } \sigma_{\min} < \text{Daya dukung izin tanah}$$

$$\sigma_{\max} = 14,89 \text{ t/m}^2 > 12,33 \text{ ton/m}^2 \quad \text{.....tidak memenuhi syarat}$$

$$\sigma_{\min} = 10,90 \text{ t/m}^2 < 12,33 \text{ ton/m}^2 \quad \text{..... memenuhi syarat}$$

Pada perhitungan di atas dapat dilihat bahwa tegangan yang terjadi pada konstruksi melebihi daya dukung izin tanah sehingga diperlukan satu perlakuan untuk mengatasi masalah tersebut, yaitu dengan menggunakan alternatif berupa pondasi tiang pancang.

Perhitungan analisis stabilitas pada berbagai kondisi disajikan pada Tabel 4.4 sampai dengan Tabel 4.7. Diagram gaya yang bekerja pada bendung gerak (*barrage*) sesuai dengan kondisi yang dianalisis disajikan pada Gambar 4.10. sampai dengan Gambar 4.11. Rekapitulasi hasil perhitungan stabilitas bendung gerak (*barrage*) dengan berbagai kondisi yang telah dianalisis pada halaman sebelumnya, disajikan pada Tabel 4.8.

UNIVERSITAS BRAWIJAYA



**Tabel 4.2. Perhitungan Gaya Uplift tiap titik pada Bendung Gerak Kondisi Muka Air Normal**

Elevasi Air EL.65,70 m  
 Panjang Creep = 73,720  
 Tinggi air di hulu = 5,700  
 Tinggi air di hilir = 2,000

Titik	Garis	Panjang Rembesan				$\Delta H$	Hx	Uplift
		Vertikal [ 1 ]	Horizontal [ 2 ]	1/3.Horizontal [ 3 ]	Lw [ 4 ]			
A1					0,000	0,000	5,700	5,700
	A1 - A2	2,000						
A2					2,000	0,209	7,700	7,491
	A2 - A3		0,500	0,167				
A3					2,167	0,226	7,700	7,474
	A3 - A4	1,000	0,500	0,167				
A4					3,333	0,348	6,700	6,352
	A4 - A5		9,000	3,000				
A5					6,333	0,662	6,700	6,038
	A4 - A6	0,300						
A6					6,633	0,693	7,000	6,307
	A4 - A7		0,500	0,167				
A7					6,800	0,710	7,000	6,290
	A4 - A8	0,380						
A8					7,180	0,750	6,620	5,870
	A4 - B	0,920	4,599	1,533				
B					9,633	1,006	5,700	4,694
	B-C		0,901	0,300				
C					9,933	1,038	5,700	4,662
	C-D	1,000						
D					10,933	1,142	6,700	5,558
	D-E	1,000	1,000	0,333				
E					12,267	1,281	7,700	6,419
	E-F	4,000						
F					16,267	1,699	11,700	10,001
	F-G		0,500	0,167				
G					16,433	1,716	11,700	9,984
	G - H	8,000						
H					24,433	2,552	19,700	17,148
	H - I	8,000						
I					32,433	3,388	11,700	8,312
	I - J		13,100	4,367				
J					36,800	3,844	11,700	7,856
	J - K	2,000	2,000	0,667				
K					39,467	4,122	13,700	9,578
	K - L		5,500	1,833				
L					41,300	4,314	13,700	9,386
	L - M	6,000						
M					47,300	4,940	19,700	14,760
	M - N	6,000						
N					53,300	5,567	13,700	8,133
	N - O		0,500	0,167				
O					53,467	5,585	13,700	8,115
	O - Q	0,537	10,000	3,333				
Q					57,337	5,989	13,163	7,174
	Q - R	0,537	10,000	3,333				
R					61,207	6,393	12,626	6,233
	R - S	0,429	8,000	2,667				
S					64,303	6,716	12,197	5,481
	S - T	2,500	1,000	0,333				
T					67,136	7,012	14,697	7,685
	T - U		1,000	0,333				
U					67,470	7,047	14,697	7,650
	U - V	6,250						
V					73,720	7,700	8,447	0,747

Sumber: Hasil Perhitungan

$$\begin{aligned}
 C_w (\text{Lane}) &= \frac{L_w}{H_w} \\
 &= \frac{73,720}{7,700} \\
 &= 9,574 > 6 \quad \text{Aman}
 \end{aligned}$$

Keterangan:

- [ 1 ] = panjang rembesan vertikal tiap garis (m)
- [ 2 ] = panjang rembesan horizontal tiap garis (m)
- [ 3 ] = [ 2 ] \* 1/3
- [ 4 ] = jarak kumulatif di tiap titik (m)  
= [ 1 ]<sub>n</sub> + [ 3 ]<sub>n-1</sub>
- [ 5 ] = pengurangan tekanan air (t/m)  
= Lw/Cw
- [ 6 ] = jarak muka air ke titik x (t/m)
- [ 7 ] = gaya uplift (t/m)  
= [ 6 ] - [ 5 ]

$$\begin{aligned}
 H_w &= \text{Tinggi Energi hulu} - \text{tinggi energi di hilir} \\
 &= 7,700
 \end{aligned}$$



**Tabel 4.3. Perhitungan Gaya Uplift tiap titik pada Bendung Gerak Kondisi Muka Air Banjir**

Elevasi Air EL.66,07 m  
 Panjang Creep = 73,720  
 Tinggi air di hulu = 5,700  
 Tinggi air di hilir = 2,000

Titik	Garis	Panjang Rembesan				$\Delta H = \frac{L_w}{C_w}$	H air	Uplift
		Vertikal	Horizontal	1/3.Horizontal	Lw			
		[ 1 ]	[ 2 ]	[ 3 ]	[ 4 ]	[ 5 ]	[ 6 ]	[ 7 ]
A1					0,000	0,000	6,070	6,070
A2	A1 - A2	2,000			2,000	0,099	8,070	7,971
A3	A1 - A3		0,500	0,167	2,167	0,108	8,070	7,962
A4	A1 - A4	1,000	0,500	0,167	3,333	0,165	7,070	6,905
A5	A1 - A5		9,000	3,000	6,333	0,314	7,070	6,756
A6	A1 - A6	0,300			6,633	0,329	7,370	7,041
A7	A1 - A7		0,500	0,167	6,800	0,338	7,370	7,032
A8	A1 - A8	0,380			7,180	0,356	6,990	6,634
	A1 - A9	0,920	4,599	1,533	9,633	0,478	6,070	5,592
B					9,933	0,493	6,070	5,577
	B-C		0,901	0,300	10,933	0,543	7,070	6,527
C		1,000			12,267	0,609	8,070	7,461
	C-D	1,000	1,000	0,333	16,267	0,808	12,070	11,262
D					16,433	0,816	12,070	11,254
	D-E	1,000	1,000	0,333	24,433	1,213	20,070	18,857
E					32,433	1,610	12,070	10,460
	E-F	4,000			36,800	1,827	12,070	10,243
F			0,500	0,167	39,467	1,959	14,070	12,111
	F-G		0,500	0,167	41,300	2,050	14,070	12,020
G		8,000			47,300	2,348	20,070	17,722
	G - H	8,000			53,300	2,646	14,070	11,424
H					53,467	2,654	14,070	11,416
	H - I	8,000			57,337	2,847	13,533	10,686
I			13,100	4,367	61,207	3,039	12,996	9,957
	I - J		13,100	4,367	64,303	3,192	12,567	9,375
J		2,000	2,000	0,667	67,136	3,333	15,067	11,734
	J - K	2,000	2,000	0,667	67,470	3,350	15,067	11,717
K			5,500	1,833	73,720	3,660	8,817	5,157
	K - L		5,500	1,833				
L		6,000						
	L - M	6,000						
M								
	M - N	6,000						
N			0,500	0,167				
	N - O		0,500	0,167				
O		0,537	10,000	3,333				
	O - Q	0,537	10,000	3,333				
Q		0,537	10,000	3,333				
	Q - R	0,537	10,000	3,333				
R		0,429	8,000	2,667				
	R - S	0,429	8,000	2,667				
S		2,500	1,000	0,333				
	S - T	2,500	1,000	0,333				
T			1,000	0,333				
	T - U		1,000	0,333				
U		6,250						
	U - V	6,250						
V					73,720	3,660	8,817	5,157

Sumber: Hasil Perhitungan

$$\begin{aligned}
 C_w (\text{Lane}) &= \frac{L_w}{H_w} \\
 &= \frac{73.720}{3.660} \\
 &= 20,142 > 6 \quad \text{Aman}
 \end{aligned}$$

Keterangan:

- [ 1 ] = panjang rembesan vertikal tiap garis (m)
  - [ 2 ] = panjang rembesan horizontal tiap garis (m)
  - [ 3 ] = [ 2 ] \* 1/3
  - [ 4 ] = jarak kumulatif di tiap titik (m)  
= [ 1 ]<sub>n</sub> + [ 3 ]<sub>n-1</sub>
  - [ 5 ] = pengurangan tekanan air (t/m)  
= Lw/Cw
  - [ 6 ] = jarak muka air ke titik x (t/m)
  - [ 7 ] = gaya uplift (t/m)  
= [ 6 ] - [ 5 ]
- Hw = Tinggi Energi hulu - tinggi energi di hilir  
= 3,660











**Tabel 4.7. Analisis Stabilitas Bendung Gerak pada Kondisi Muka Air Banjir (Gempa)**

Notasi	Nilai				Ratio	γ (t/m <sup>3</sup> )	Gaya		Lengan Momen		Momen			
	Lebar (m)	Tinggi (m)	Panjang (m)				Pv (ton)	Ph (ton)	x (m)	y (m)	Mx (ton.m)	My (ton.m)		
	[1]	[2]	[3]	[4]			[6]	[7]	[8]	[9]	[10]	[11]		
Wc1	7,500	x	1,000	x	15,000	x	1,000	=	270,000	40,500	14,850	9,500	4009,500	384,750
Wc2	10,500	x	7,000	x	15,000	x	1,000	=	2646,000	396,900	15,850	5,500	41939,100	2182,950
Wc3	5,997	x	5,997	x	15,000	x	0,500	=	647,352	97,103	9,101	6,002	5891,552	582,811
Wc4	5,100	x	2,003	x	15,000	x	1,000	=	367,751	55,163	8,550	3,001	3144,269	165,543
Wc5	2,000	x	2,000	x	15,000	x	0,500	=	72,000	10,800	6,667	1,333	480,024	14,396
Wc6	6,000	x	4,003	x	15,000	x	1,000	=	864,648	129,697	3,000	2,001	2593,944	259,524
P1	4,000	x	6,300	x	2,500	x	1,000	=	151,200	22,680	13,100	18,720	1980,720	424,570
P2	3,000	x	1,000	x	2,500	x	1,000	=	18,000	2,700	20,100	9,503	361,800	25,658
P3	16,497	x	5,570	x	2,500	x	1,000	=	551,330	82,699	13,351	12,785	7360,803	1057,313
P4	5,997	x	5,997	x	2,500	x	0,500	=	107,892	16,184	7,102	8,001	766,249	129,487
P5	1,503	x	11,567	x	2,500	x	1,000	=	104,311	15,647	4,351	9,786	453,858	153,118
P6	3,000	x	11,567	x	2,500	x	0,500	=	104,103	15,615	2,600	7,859	270,668	122,722
PA								=	99,840	14,976	13,100	11,900	1307,904	178,214
RP								=	59,750	8,963	13,100	23,695	782,725	212,366
JK								=	117,347	17,602	7,341	16,085	861,444	283,129
Ww1	3,000	x	1,000	x	15,000	x	1,000	=	45,000		16,773		904,500	
Ww2	7,137	x	4,070	x	15,000	x	1,000	=	435,714		17,846		7775,749	
Ww3	3,657	x	3,657	x	15,000	x	0,500	=	100,302		13,244		1328,405	
Ww4	12,200	x	0,413	x	15,000	x	1,000	=	182,400		7,579		632,067	
Ww5	5,997	x	5,997	x	15,000	x	0,500	=	269,730		7,102		1915,623	
Ww6	2,840	x	5,997	x	15,000	x	1,000	=	255,472		3,683		940,904	
Ww7	1,662	x	6,410	x	15,000	x	0,500	=	79,901		1,708		136,470	
Pu1	0,500	x	11,254	x	15,000			=	-84,406		21,350		-1802,067	
	0,500	x	0,008	x	15,000	x	0,500	=	-0,031		21,433		-0,665	
Pu2	13,100	x	10,243	x	15,000			=	-2012,744		14,550		-29285,421	
	13,100	x	0,217	x	15,000	x	0,500	=	-21,300		16,733		-356,421	
Pu3	2,000	x	10,243	x	15,000			=	-307,289		7,000		-2151,024	
	2,000	x	1,868	x	15,000	x	0,500	=	-28,014		6,667		-186,761	
Pu4	5,500	x	12,020	x	15,000			=	-991,613		3,250		-3222,744	
	5,500	x	0,091	x	15,000	x	0,500	=	-3,755		4,167		-15,644	
Pu5	0,500	x	11,416	x	15,000			=	-85,616		0,250		-21,404	
	0,500	x	0,008	x	15,000	x	0,500	=	-0,031		0,333		-0,010	
Pd1			6,070	x	15,000			=			21,808		10,023	218,585
Pw1	6,070	x	6,070	x	15,000	x	0,500	=	276,337		10,023		2769,815	
Pw2	5,070	x	1,000	x	15,000			=	76,050		8,500		646,425	
	0,522	x	1,000	x	15,000	x	0,500	=			3,913		8,333	32,609
Pw3	5,577	x	1,000	x	15,000			=	83,653		7,500		627,394	
	0,950	x	1,000	x	15,000	x	0,500	=			7,128		7,333	52,269
Pw4	6,527	x	1,000	x	15,000			=	97,908		6,500		636,401	
	0,934	x	1,000	x	15,000	x	0,500	=			7,004		6,333	44,356
Pw5	7,461	x	4,000	x	15,000			=	447,659		4,000		1790,638	
	3,801	x	4,000	x	15,000	x	0,500	=			114,042		3,333	380,141
Pw6	10,243	x	2,000	x	15,000			=	307,289		1,000		307,289	
	1,868	x	2,000	x	15,000	x	0,500	=			28,014		0,667	18,676
Pae	0,500	x	Kae	x	γsub	x	H	x	H	x	Panjang			
	0,500	x	0,368	x	0,976	x	8,000	x	8,000	x	15,000			
Pw7	6,410	x	6,410	x	15,000	x	0,500	=			-308,161		5,139	-1583,638
Pw8	6,410	x	4,003	x	15,000			=			-384,888		2,002	-770,354
	5,006	x	4,003	x	15,000	x	0,500	=			-150,278		1,334	-200,521
Ppe	0,500	x	Kpe	x	γsub	x	H	x	H	x	Panjang			
	0,500	x	2,716	x	0,976	x	4,003	x	4,003	x	15,000			
TOTAL								=	Σ V	3908,423		Σ Mv	48796,119	
								=	Σ H		1408,596		Σ Mh	11181,625
Angka keamanan terhadap guling dan geser kondisi gempa :														
SF Guling = Σ M v / Σ M h = 4,36 > 1,2 Aman														
SF Geser = (f Σ V) / Σ H = 1,94 > 1,2 Aman														
Kontrol terhadap eksentrisitas dan daya dukung izin tanah :														
Eksentrisitas :														
L = 21,600 m														
e = 1,18														
L / 6 = 3,60 Aman														
f = 0,7														
Ø = 27,5 °														
Tegangan maksimum dan minimum yang terjadi di bawah dasar pondasi :														
Tegangan izin tanah = 12,33 ton/m <sup>2</sup>														
Tegangan maks = 16,00 ton/m <sup>2</sup> > Tegangan izin tanah, Tidak aman														
Tegangan min = 8,12 ton/m <sup>2</sup> < Tegangan izin tanah , Aman														

Sumber: Hasil Perhitungan

Keterangan:

- [ 1 ] = lebar tiap bagian (m)
- [ 2 ] = tinggi tiap bagian (m)
- [ 3 ] = panjang konstruksi, tiap 15 meter panjang (m)
- [ 4 ] = 1 digunakan untuk penampang persegi atau persegi panjang  
= 0,5 digunakan untuk penampang segitiga
- [ 5 ] = berat jenis beton bertulang = 2,4 (t/m<sup>3</sup>)  
= berat jenis air = 1,0 (t/m<sup>3</sup>)
- [ 6 ] = gaya vertikal (ton)  
= [ 1 ] \* [ 2 ] \* [ 3 ] \* [ 4 ] \* [ 5 ] \* [ 6 ] (untuk bangunan dan Uplift )  
nilai (+) untuk arah gaya ke bawah  
nilai (-) untuk arah gaya ke atas
- [ 7 ] = gaya horizontal (ton)  
= [ 5 ] \* kh, dengan kh = 0,15 (untuk berat bangunan)  
= 7/12 \* [ 2 ]<sup>2</sup> \* [ 3 ] \* [ 5 ] \* [ 1 - (hd' / [ 2 ])<sup>1,5</sup> ] \* kh (untuk tekanan air dinamis)  
nilai (+) untuk arah gaya ke hilir  
nilai (-) untuk arah gaya ke hulu
- [ 8 ] = lengan momen gaya vertikal (m)
- [ 9 ] = lengan momen gaya horizontal (m)
- [ 10 ] = momen x (ton.m)  
= [ 7 ] \* [ 9 ]
- [ 11 ] = momen y (ton.m)  
= [ 8 ] \* [ 10 ]



Tabel 4.8. Rekapitulasi Perhitungan Stabilitas Bendung Gerak (*Barrage*)

No.	Tinjauan analisa stabilitas	Angka keamanan terhadap guling		Angka keamanan terhadap geser		Eksentrisitas	L/6	Kontrol Eksentrisitas	Tegangan maks	Tegangan min	Tegangan izin	Kontrol Daya dukung
		SF Guling	SF Geser	e	$\sigma$ maks							
<b>A</b>	<b>Tinjauan Kondisi Normal</b>	SF > 1,5		SF > 1,5				$e \leq L/6$				$< \sigma$ izin
1	Muka Air Normal	8,719	Aman	3,268	Aman	0,557	3,600	Aman	14,889	10,897	12,326	Tidak Aman
2	Muka Air Banjir	12,099	Aman	5,950	Aman	0,653	3,600	Aman	14,251	9,875	12,326	Tidak Aman
<b>B</b>	<b>Tinjauan Kondisi Gempa</b>	SF > 1,2		SF > 1,2				$e \leq L/6$				$< \sigma$ izin
1	Muka Air Normal	4,279	Aman	1,587	Aman	0,969	3,600	Aman	16,365	9,421	12,326	Tidak Aman
2	Muka Air Banjir	4,364	Aman	1,942	Aman	1,176	3,600	Aman	16,004	8,122	12,326	Tidak Aman

Sumber: Hasil Perhitungan

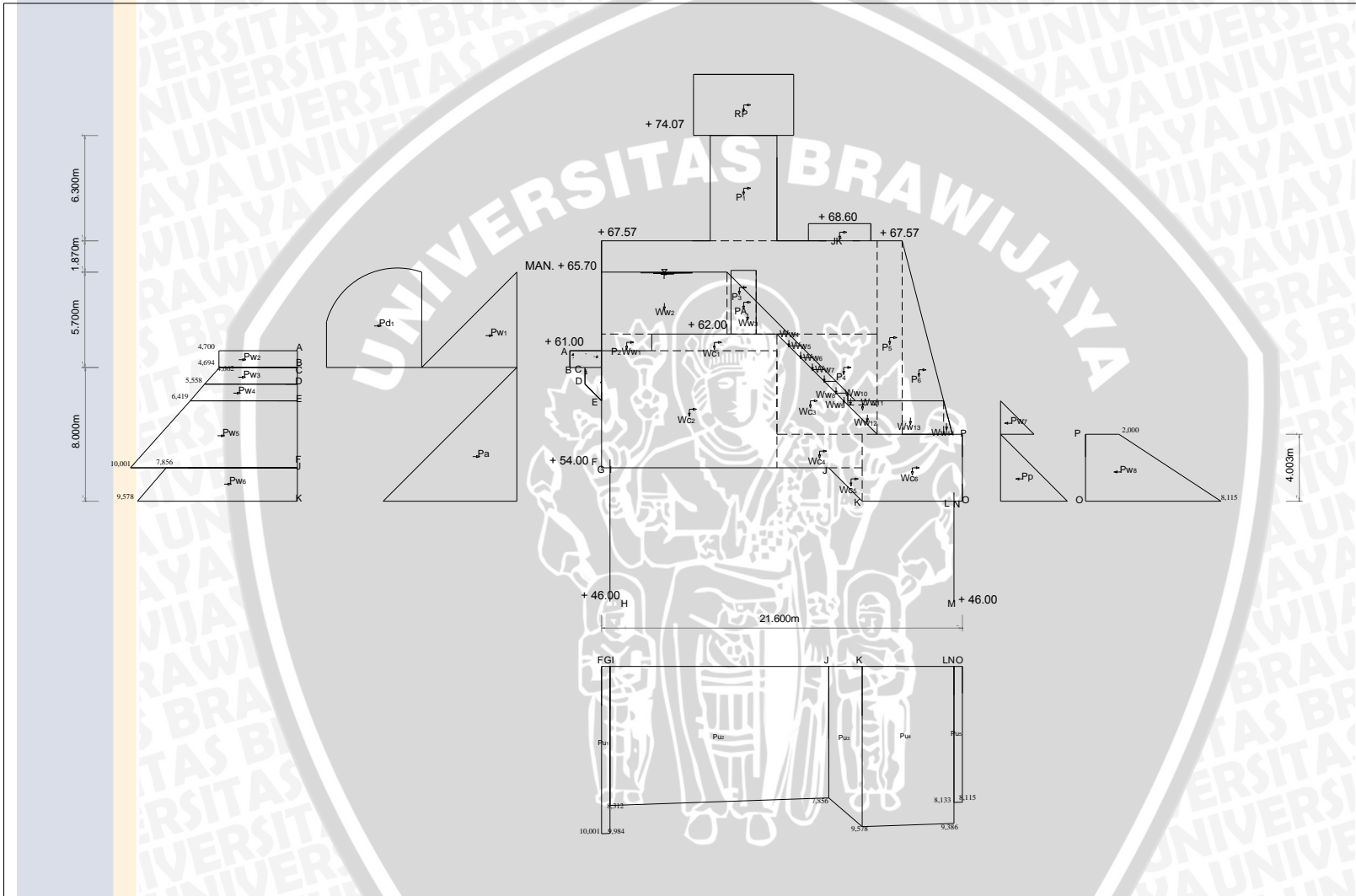

Gambar 4.10. Diagram Gaya Pada Bendung Gerak (Barrage) pada Kondisi Muka Air Normal

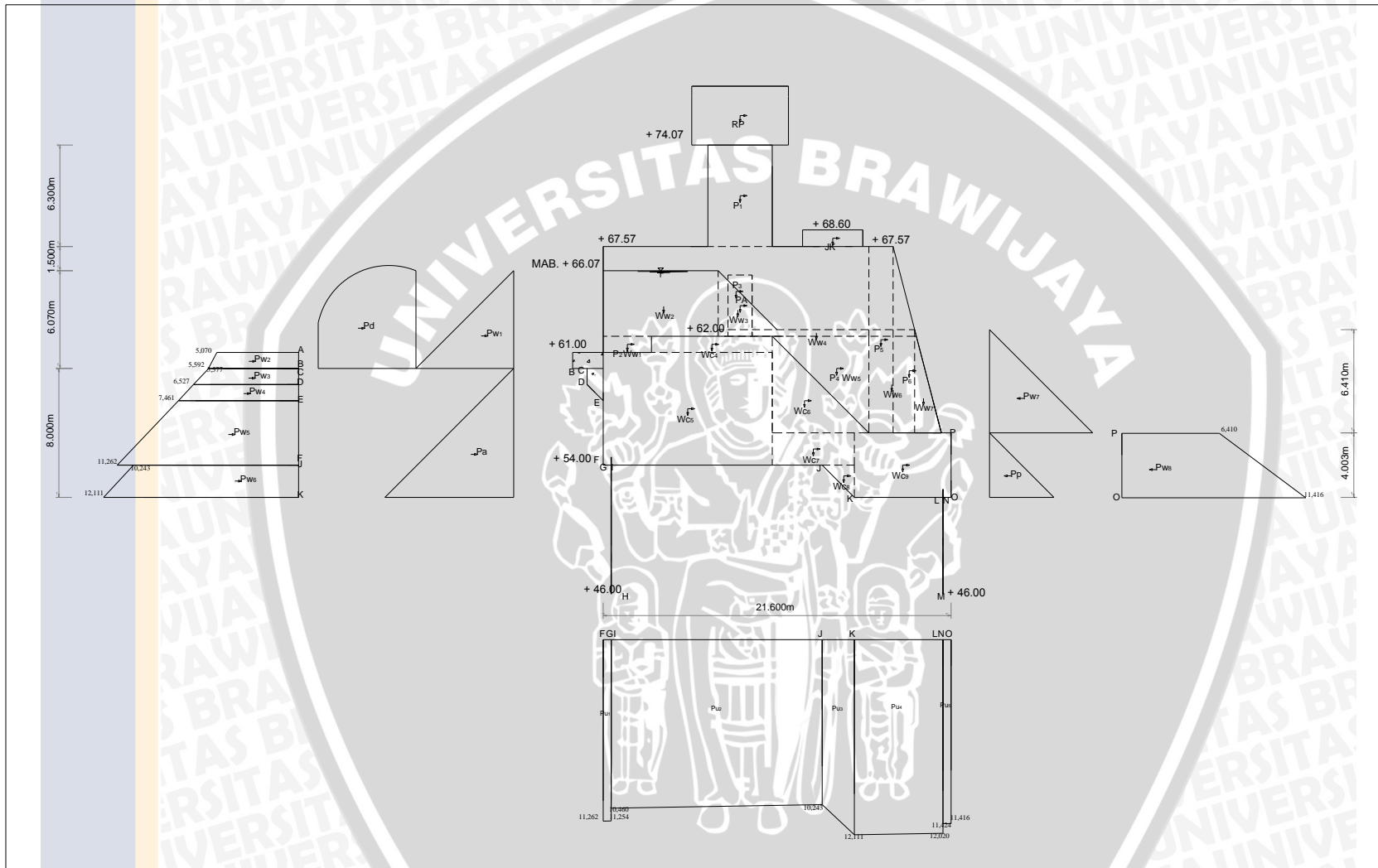

Gambar 4.11. Diagram Gaya Pada Bendung Gerak (*Barrage*) pada Kondisi Muka Air Banjir

#### 4.3.2. Bangunan Penguras (*Sluice Gate*)

Gaya berat dari bangunan penguras disesuaikan dengan dimensi dari bangunan tersebut. Untuk mempermudah dalam menganalisis perhitungan stabilitas pada bangunan penguras ini dilakukan dengan menganalisis per panel, dapat dilihat pada Gambar 4.12. Sedangkan untuk mempermudah dalam perhitungan beban vertikal maka bangunan perlu dibagi menjadi bagian-bagian kecil yang disajikan secara visual seperti pada Gambar 4.13. Perhitungan gaya berat pada bangunan penguras menggunakan persamaan (2-12) dapat dilihat pada Tabel 4.9.

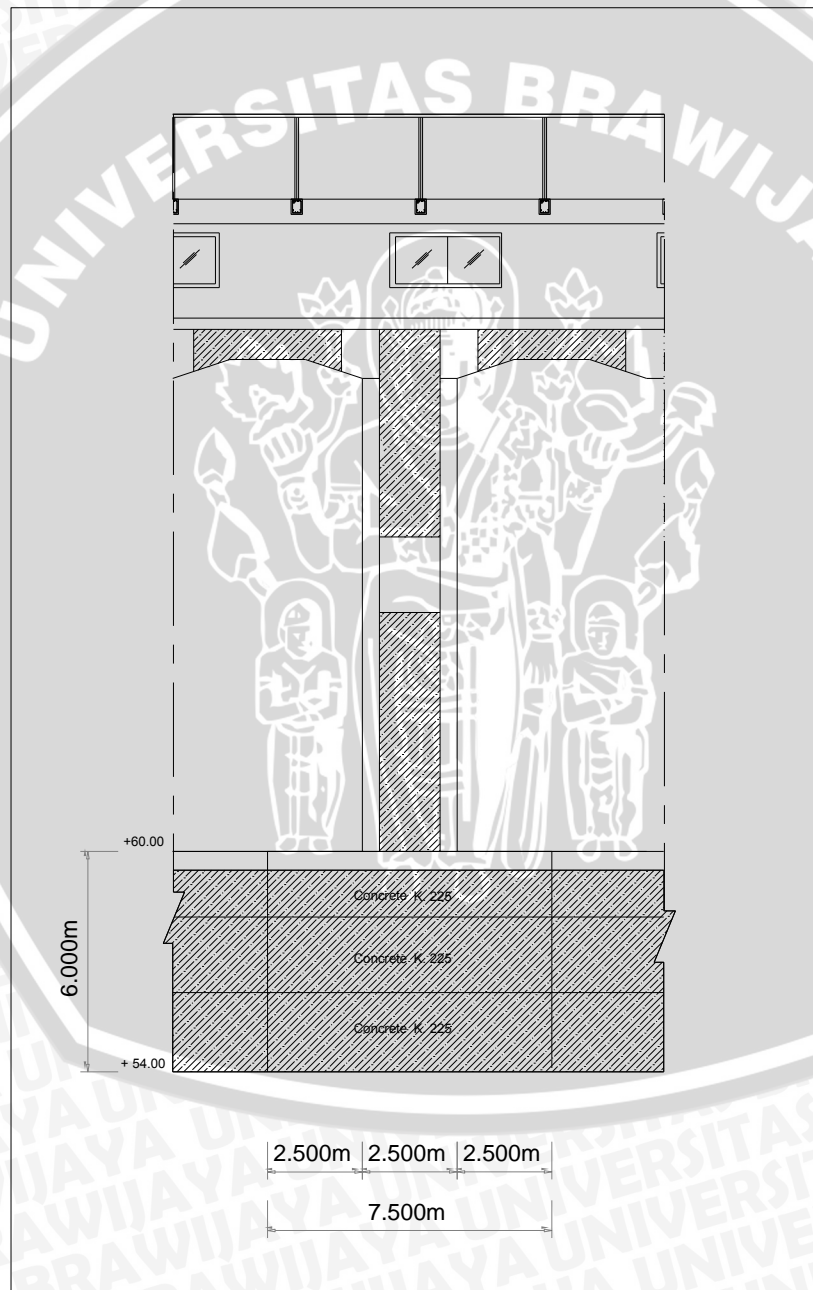

**Gambar 4.12. Potongan Melintang Bangunan Penguras per Satu Panel**

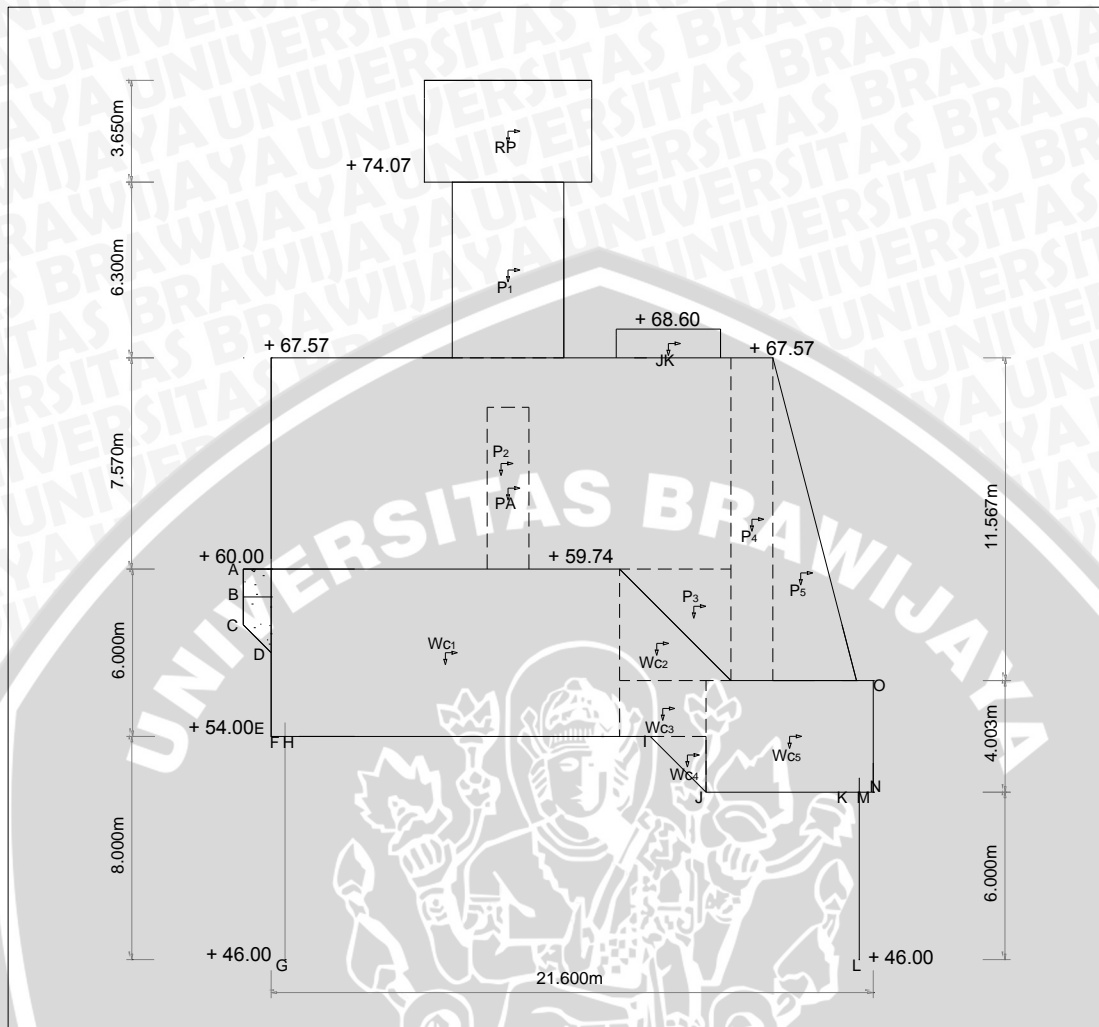

**Gambar 4.13. Gaya Berat pada Bangunan Penguras (Sluice Gate)**



**Tabel 4.9. Perhitungan Gaya Berat pada Bangunan Penguras (Sluice Gate)**

Notasi	Nilai				Volume	$\gamma$	Gaya Berat
	Lebar	Tinggi	Panjang	Ratio			
		m	m	m	$m^3$	$(t/m^3)$	(t)
	[ 1 ]	[ 2 ]	[ 3 ]	[ 4 ]	[ 5 ]	[ 6 ]	[ 7 ]
Wc1	12,500	6,000	7,500	1,000	562,500	2,400	1350,000
Wc2	3,997	3,997	7,500	0,500	59,910	2,400	143,784
Wc3	3,100	2,003	7,500	1,000	46,570	2,400	111,767
Wc4	2,000	2,000	7,500	0,500	15,000	2,400	36,000
Wc5	6,000	4,003	7,500	1,000	180,135	2,400	432,324
P1	4,000	6,300	2,500	1,000	63,000	2,400	151,200
P2	16,497	7,570	2,500	1,000	312,206	2,400	749,294
P3	3,997	3,997	2,500	0,500	19,970	2,400	47,928
P4	1,503	11,567	2,500	1,000	43,463	2,400	104,311
P5	3,000	11,567	2,500	0,500	43,376	2,400	104,103
PA							60,955
RP							29,875
JK							58,674
Total							3380,215

Sumber: Hasil Perhitungan

Keterangan:

- [ 1 ] = lebar tiap bagian (m)  
 [ 2 ] = tinggi tiap bagian (m)  
 [ 3 ] = panjang konstruksi, tiap 7,5 meter panjang (m)  
 [ 4 ] = 1 digunakan untuk penampang persegi atau persegi panjang  
 = 0,5 digunakan untuk penampang segitiga  
 [ 5 ] = volume ( $m^3$ )  
 = [ 1 ] \* [ 2 ] \* [ 3 ] \* [ 4 ]  
 [ 6 ] = berat jenis beton bertulang = 2,4 ( $t/m^3$ )  
 [ 7 ] = gaya berat konstruksi (ton)  
 = [ 5 ] \* [ 6 ]

Perhitungan uplift pada kondisi normal maupun pada kondisi banjir disajikan pada Tabel 4.10 dan 4.11. Perhitungan analisis stabilitas pada berbagai kondisi disajikan pada Tabel 4.12 sampai dengan Tabel 4.15. Diagram gaya yang bekerja pada bangunan penguras (*sluice gate*) sesuai dengan kondisi yang dianalisis disajikan pada Gambar 4.14. sampai dengan Gambar 4.15. Rekapitulasi hasil perhitungan stabilitas bangunan penguras dengan berbagai kondisi yang telah dianalisis pada halaman sebelumnya, disajikan pada Tabel 4.16.

**Tabel 4.10. Perhitungan Gaya Uplift Tiap Titik Pada Bangunan Penguras Kondisi Muka Air Normal**

Elevasi Air EL.65,70 m

Panjang Creep = 73,121

Tinggi air di hulu = 5,700

Tinggi air di hilir = 2,000

Titik	Garis	Panjang Rembesan				ΔH	Hx	Uplift
		Vertikal	Horizontal	1/3.Horizontal	Lw			
		[ 1 ]	[ 2 ]	[ 3 ]	[ 4 ]	[ 5 ]	[ 6 ]	[ 7 ]
A1					0,000	0,000	5,700	5,700
	A1 - A2	2,000						
A2					2,000	0,211	7,700	7,489
	A2 - A3		0,500	0,167				
A3					2,167	0,228	7,700	7,472
	A3 - A4	1,000	0,500	0,167				
A4					3,333	0,351	6,700	6,349
	A4 - A5		9,000	3,000				
A5					6,333	0,667	6,700	6,033
	A4 - A5	1,000						
A6					7,333	0,772	7,700	6,928
	A5 - A6		0,500	0,167				
A7					7,500	0,790	7,700	6,910
	A7 - A8	1,000						
A8					8,500	0,895	6,700	5,805
	A8 - B		5,500	1,833				
B					10,333	1,088	6,700	5,612
	B-C	1,000						
C					11,333	1,193	7,700	6,507
	C-D	1,000	1,000	0,333				
D					12,667	1,334	8,700	7,366
	D-E	3,000						
E					15,667	1,650	11,700	10,050
	E-F		0,500	0,167				
F					15,833	1,667	11,700	10,033
	F-G	8,000						
G					23,833	2,510	19,700	17,190
	G - H	8,000						
H					31,833	3,352	11,700	8,348
	H - I		13,100	4,367				
I					36,200	3,812	11,700	7,888
	I - J	2,000	2,000	0,667				
J					38,867	4,093	13,700	9,607
	J - K		5,500	1,833				
K					40,700	4,286	13,700	9,414
	K - L	6,000						
L					46,700	4,918	19,700	14,782
	L - M	6,000						
M					52,700	5,550	13,700	8,150
	M - N		0,500	0,167				
N					52,867	5,567	13,700	8,133
	N - P	0,505	10,000	3,333				
P					56,705	5,971	13,195	7,224
	P - Q	0,555	10,000	3,333				
Q					60,593	6,381	12,640	6,259
	Q - R	0,444	8,000	2,667				
R					63,704	6,708	12,196	5,488
	R - S	2,500	1,000	0,333				
S					66,537	7,007	14,696	7,689
	S - T		1,000	0,333				
T					66,871	7,042	14,696	7,654
	T - U	6,250						
U					73,121	7,700	8,446	0,746

Sumber: Hasil Perhitungan

$$\begin{aligned}
 C_w (\text{Lane}) &= \frac{L_w}{H_w} \\
 &= \frac{73,121}{7,700} \\
 &= 9,496 > 6 \quad \text{Aman}
 \end{aligned}$$

Keterangan:

- [ 1 ] = panjang rembesan vertikal tiap garis (m)
- [ 2 ] = panjang rembesan horizontal tiap garis (m)
- [ 3 ] = [ 2 ] \* 1/3
- [ 4 ] = jarak kumulatif di tiap titik (m)  
= [ 1 ]<sub>n</sub> + [ 3 ]<sub>n-1</sub>
- [ 5 ] = pengurangan tekanan air (t/m)  
= Lw/Cw
- [ 6 ] = jarak muka air ke titik x (t/m)
- [ 7 ] = gaya uplift (t/m)  
= [ 6 ] - [ 5 ]

$$\begin{aligned}
 H_w &= \text{Tinggi Energi hulu - tinggi energi di hilir} \\
 &= 7,700
 \end{aligned}$$



**Tabel 4.11. Perhitungan Gaya Uplift tiap titik pada Bangunan Penguras Kondisi Muka Air Banjir**

Elevasi Air EL.66,07 m  
 Panjang Creep = 73,121  
 Tinggi air di hulu = 5,700  
 Tinggi air di hilir = 2,000

Titik	Garis	Panjang Rembesan				$\Delta H = \frac{Lw}{Cw}$	H air	Uplift
		Vertikal	Horizontal	1/3.Horizontal	Lw			
		[ 1 ]	[ 2 ]	[ 3 ]	[ 4 ]			
A1					0,000	0,000	6,070	6,070
A2	A1 - A2	2,000			2,000	0,100	8,070	7,970
A3	A2 - A3		0,500	0,167	2,167	0,108	8,070	7,962
A4	A3 - A4	1,000	0,500	0,167	3,333	0,167	7,070	6,903
A5	A4 - A5		9,000	3,000	6,333	0,317	7,070	6,753
A6	A1 - A4	1,000			7,333	0,367	8,070	7,703
A7	A2 - A5		0,500	0,167	7,500	0,375	8,070	7,695
A8	A6 - A7	1,000			8,500	0,425	7,070	6,645
B	A8 - B		5,500	1,833	10,333	0,517	7,070	6,553
C	B-C	1,000		0,000	11,333	0,567	8,070	7,503
D	C-D	1,000	1,000	0,333	12,667	0,634	9,070	8,436
E	D-E	3,000			15,667	0,784	12,070	11,286
F	E-F		0,500	0,167	15,833	0,793	12,070	11,277
G	F-G	8,000			23,833	1,193	20,070	18,877
H	G - H	8,000			31,833	1,593	12,070	10,477
I	H - I		13,100	4,367	36,200	1,812	12,070	10,258
J	I - J	2,000	2,000	0,667	38,867	1,945	14,070	12,125
K	J - K		5,500	1,833	40,700	2,037	14,070	12,033
L	K - L	6,000			46,700	2,338	20,070	17,732
M	L - M	6,000			52,700	2,638	14,070	11,432
N	M - N		0,500	0,167	52,867	2,646	14,070	11,424
P	N - P	0,505	10,000	3,333	56,705	2,838	13,565	10,727
Q	P - Q	0,555	10,000	3,333	60,593	3,033	13,010	9,977
R	Q - R	0,444	8,000	2,667	63,704	3,189	12,566	9,377
S	R - S	2,500	1,000	0,333	66,537	3,330	15,066	11,736
T	S - T		1,000	0,333	66,871	3,347	15,066	11,719
U	T - U	6,250			73,121	3,660	8,816	5,156

Sumber: Hasil Perhitungan

$$\begin{aligned}
 C_w (\text{Lane}) &= \frac{L_w}{H_w} \\
 &= \frac{73,121}{3,660} \\
 &= 19,978 > 6 \quad \text{Aman}
 \end{aligned}$$

Keterangan:

- [ 1 ] = panjang rembesan vertikal tiap garis (m)
- [ 2 ] = panjang rembesan horizontal tiap garis (m)
- [ 3 ] = [ 2 ] \* 1/3
- [ 4 ] = jarak kumulatif di tiap titik (m)  
= [ 1 ]<sub>n</sub> + [ 3 ]<sub>n-1</sub>
- [ 5 ] = pengurangan tekanan air (t/m)  
= Lw/Cw
- [ 6 ] = jarak muka air ke titik x (t/m)
- [ 7 ] = gaya uplift (t/m)  
= [ 6 ] - [ 5 ]

$$\begin{aligned}
 H_w &= \text{Tinggi Energi hulu - tinggi energi di hilir} \\
 &= 3,660
 \end{aligned}$$



Tabel 4.12. Analisis Stabilitas Bangunan Penguras pada Kondisi Muka Air Normal (Tanpa Gempa)

Notasi	Nilai				Gaya			Lengan Momen		Momen	
	Lebar (m)	Tinggi (m)	Panjang (m)	Ratio	$\gamma$ (t/m <sup>3</sup> )	Pv (ton)	Ph (ton)	x (m)	y (m)	Mx (ton.m)	My (ton.m)
	[1]	[2]	[3]	[4]	[5]	[6]	[7]	[8]	[9]	[10]	[11]
Wc1	12.500	6.000	7.500	1.000	2.400	1350.000		15.350		20722.500	
Wc2	3.997	3.997	7.500	0.500	2.400	143.784		7.768		1116.915	
Wc3	3.100	2.003	7.500	1.000	2.400	111.767		7.550		843.844	
Wc4	2.000	2.000	7.500	0.500	2.400	36.000		6.667		240.012	
Wc5	6.000	4.003	7.500	1.000	2.400	432.324		3.000		1296.972	
P1	4.000	6.300	2.500	1.000	2.400	151.200		13.100		1980.720	
P2	16.497	7.570	2.500	1.000	2.400	749.294		13.351		10003.821	
P3	3.997	3.997	2.500	0.500	2.400	47.928		6.435		308.417	
P4	1.503	11.567	2.500	1.000	2.400	104.311		4.351		453.858	
P5	3.000	11.567	2.500	0.500	2.400	104.103		2.600		270.668	
PA						60.955		13.100		798.511	
RP						29.875		13.100		391.363	
JK						58.674		7.347		431.074	
Ww1	7.507	5.700	7.500	1.000	1.000	320.924		17.846		5727.214	
Ww2	5.700	5.700	7.500	0.500	1.000	121.838		12.193		1485.565	
Ww3	0.707	0.707	7.500	1.000	1.000	3.749		8.393		31.464	
Ww4	0.707	0.707	7.500	1.000	1.000	3.749		7.686		28.814	
Ww5	0.707	0.707	7.500	0.500	1.000	1.874		7.214		13.522	
Ww6	0.583	0.583	7.500	0.500	1.000	1.275		6.784		8.647	
Ww7	1.876	1.876	7.500	0.500	1.000	13.198		5.728		75.596	
Ww8	5.860	0.124	7.500	1.000	1.000	5.450		4.049		22.066	
Ww9	3.984	1.876	7.500	1.000	1.000	56.055		3.111		174.387	
Ww10	0.519	2.000	7.500	0.500	1.000	3.893		0.946		3.682	
Pu1	0.500	10.033	7.500		1.000	-37.622		21.350		-803.240	
	0.500	0.018	7.500	0.500	1.000	-0.033		21.433		-0.705	
Pu2	13.100	7.888	7.500		1.000	-774.991		14.550		-11276.113	
	13.100	0.460	7.500	0.500	1.000	-22.589		16.733		-377.995	
Pu3	2.000	7.888	7.500		1.000	-118.319		7.000		-828.234	
	2.000	1.719	7.500	0.500	1.000	-12.894		6.667		-85.959	
Pu4	5.500	9.414	7.500		1.000	-388.330		3.250		-1262.074	
	5.500	0.193	7.500	0.500	1.000	-3.982		4.167		-16.591	
Pu5	0.500	8.133	7.500		1.000	-30.498		0.250		-7.625	
	0.500	0.018	7.500	0.500	1.000	-0.033		0.333		-0.011	
Pw1	5.700	5.700	7.500	0.500	1.000		121.838	9.900		1206.191	
Pw2	5.700	1.000	7.500		1.000		42.750	7.500		320.625	
	0.088	1.000	7.500	0.500	1.000		0.331	7.333		2.424	
Pw3	5.612	1.000	7.500		1.000		42.089	6.500		273.577	
	0.895	1.000	7.500	0.500	1.000		3.355	6.333		21.249	
Pw4	6.507	1.000	7.500		1.000		48.799	5.500		268.395	
	0.860	1.000	7.500	0.500	1.000		3.223	5.333		17.192	
Pw5	7.366	3.000	7.500		1.000		165.738	3.500		580.083	
	2.684	3.000	7.500	0.500	1.000		30.196	3.000		90.588	
Pw6	7.888	2.000	7.500		1.000		118.319	1.000		118.319	
	1.719	2.000	7.500	0.500	1.000		12.894	0.667		8.596	
Pa	0.500	Ka	$\gamma_{sub}$	H	H	Panjang					
	0.500	0.368	0.976	8.000	8.000	7.500		86.294	2.667	230.119	
Pw7	2.000	2.000	7.500	0.500	1.000		-15.000	4.670		-70.045	
Pw8	2.000	4.003	7.500		1.000		-60.045	2.002		-120.180	
	5.224	4.003	7.500	0.500	1.000		-78.414	1.334		-104.630	
Pp	0.500	Kp	$\gamma_{sub}$	H	H	Panjang					
	0.500	2.716	0.976	4.003	4.003	7.500		-159.349	1.334	-212.625	
TOTAL						$\Sigma V$	2522.927		$\Sigma Mv$	31771.083	
						$\Sigma H$	363.018		$\Sigma Mh$	2629.878	

Angka keamanan terhadap guling dan geser kondisi tanpa gempa :  
SF Guling =  $\Sigma M v / \Sigma M h =$  12,081 > 1,5 Aman  
SF Geser =  $(f \cdot \Sigma V) / \Sigma H =$  4,865 > 1,5 Aman  
Kontrol terhadap eksentrisitas dan daya dukung izin tanah :  
Eksentrisitas : L = 21,600 m  
e = 0,751 < L / 6 = 3,60 Aman  
f = 0,7 Tegangan maksimum dan minimum yang terjadi di bawah dasar pondasi :  
Ø = 27,5 ° Tegangan izin tanah = 11,49 ton/m<sup>2</sup>  
Tegangan maks = 18,82 ton/m<sup>2</sup> > Tegangan izin tanah, Tidak aman  
Tegangan min = 12,33 ton/m<sup>2</sup> > Tegangan izin tanah, Tidak aman

Sumber: Hasil Perhitungan

Keterangan:

- |  |  |
|--|--|
| [ 1 ] = lebar tiap bagian (m)  | [ 7 ] = gaya horizontal (ton)            |
| [ 2 ] = tinggi tiap bagian (m)   | [ 8 ] = lengan momen gaya vertikal (m)   |
| [ 3 ] = panjang konstruksi, tiap 7,5 meter panjang (m)   | [ 9 ] = lengan momen gaya horizontal (m) |
| [ 4 ] = 1 digunakan untuk penampang persegi atau persegi panjang<br>= 0,5 digunakan untuk penampang segitiga | [ 10 ] = momen x (ton.m)                 |
| [ 5 ] = berat jenis beton bertulang = 2,4 (t/m <sup>3</sup> )<br>= berat jenis air = 1,0 (t/m <sup>3</sup> ) | [ 11 ] = [ 7 ] * [ 9 ]                   |
| [ 6 ] = gaya vertikal (ton)  | [ 11 ] = momen y (ton.m)                 |
| = [ 1 ] * [ 2 ] * [ 3 ] * [ 4 ] * [ 6 ] (untuk bangunan dan Uplift )   | = [ 8 ] * [ 10 ]                         |
| nilai (+) untuk arah gaya ke bawah   |  |
| nilai (-) untuk arah gaya ke atas  |  |



Tabel 4.13. Analisis Stabilitas Bangunan Penguras pada Kondisi Muka Air Normal (Gempa)

Notasi	Nilai								γ (t/m <sup>3</sup> )	Gaya				Lengan Momen		Momen	
	Lebar (m)	Tinggi (m)	Panjang (m)	Ratio						Pv (ton)	Ph (ton)	x (m)	y (m)	Mx (ton.m)	My (ton.m)		
	[1]	[2]	[3]	[4]						[6]	[7]	[8]	[9]	[10]	[11]		
WC1	12.500	6.000	7.500	1.000				2.400	1350.000	202.500	15.350	5.000	20722.500	1012.500			
WC2	3.997	3.997	7.500	0.500				2.400	143.784	21.568	7.768	5.335	1116.915	115.063			
WC3	3.100	2.003	7.500	1.000				2.400	111.767	16.765	7.550	3.001	843.844	50.312			
WC4	2.000	2.000	7.500	0.500				2.400	36.000	5.400	6.667	1.333	240.012	7.198			
WC5	6.000	4.003	7.500	1.000				2.400	432.324	64.849	3.000	2.001	1296.972	129.762			
P1	4.000	6.300	2.500	1.000				2.400	151.200	22.680	13.100	18.720	1980.720	424.570			
P2	16.497	7.570	2.500	1.000				2.400	749.294	112.394	13.351	11.785	10003.821	1324.564			
P3	3.997	3.997	2.500	0.500				2.400	47.928	7.189	6.435	6.668	308.417	47.938			
P4	1.503	11.567	2.500	1.000				2.400	104.311	15.647	4.351	9.786	453.858	153.118			
P5	3.000	11.567	2.500	0.500				2.400	104.103	15.615	2.600	7.859	270.668	122.722			
PA									60.955	9.143	13.100	10.900	798.511	99.661			
RP									29.875	4.481	13.100	23.695	391.363	106.183			
JK									58.674	8.801	7.347	16.085	431.074	141.564			
Ww1	7.507	5.700	7.500	1.000				1.000	320.924		17.846		5727.214				
Ww2	5.700	5.700	7.500	0.500				1.000	121.838		12.193		1485.565				
Ww3	0.707	0.707	7.500	1.000				1.000	3.749		8.393		31.464				
Ww4	0.707	0.707	7.500	1.000				1.000	3.749		7.686		28.814				
Ww5	0.707	0.707	7.500	0.500				1.000	1.874		7.214		13.522				
Ww6	0.583	0.583	7.500	0.500				1.000	1.275		6.784		8.647				
Ww7	1.876	1.876	7.500	0.500				1.000	13.198		5.728		75.596				
Ww8	5.860	0.124	7.500	1.000				1.000	5.450		4.049		22.066				
Ww9	3.984	1.876	7.500	1.000				1.000	56.055		3.111		174.387				
Ww10	0.519	2.000	7.500	0.500				1.000	3.893		0.946		3.682				
Pu1	0.500	10.033	7.500					1.000	-37.622		21.350		-803.240				
	0.500	0.018	7.500	0.500				1.000	-0.033		21.433		-0.705				
Pu2	13.100	7.888	7.500					1.000	-774.991		14.550		-11276.113				
	13.100	0.460	7.500	0.500				1.000	-22.589		16.733		-377.995				
Pu3	2.000	7.888	7.500					1.000	-118.319		7.000		-828.234				
	2.000	1.719	7.500	0.500				1.000	-12.894		6.667		-85.959				
Pu4	5.500	9.414	7.500					1.000	-388.330		3.250		-1262.074				
	5.500	0.193	7.500	0.500				1.000	-3.982		4.167		-16.591				
Pu5	0.500	8.133	7.500					1.000	-30.498		0.250		-7.625				
	0.500	0.018	7.500	0.500				1.000	-0.033		0.333		-0.011				
Pd1		5.700	7.500					1.000			21.322	9.900		211.083			
Pw1	5.700	5.700	7.500	0.500				1.000			121.838	9.900		1206.191			
Pw2	5.700	1.000	7.500					1.000			42.750	7.500		320.625			
	0.088	1.000	7.500	0.500				1.000			0.331	7.333		2.424			
Pw3	5.612	1.000	7.500					1.000			42.089	6.500		273.577			
	0.895	1.000	7.500	0.500				1.000			3.355	6.333		21.249			
Pw4	6.507	1.000	7.500					1.000			48.799	5.500		268.395			
	0.860	1.000	7.500	0.500				1.000			3.223	5.333		17.192			
Pw5	7.366	3.000	7.500					1.000			165.738	3.500		580.083			
	2.684	3.000	7.500	0.500				1.000			30.196	3.000		90.588			
Pw6	7.888	2.000	7.500					1.000			118.319	1.000		118.319			
	1.719	2.000	7.500	0.500				1.000			12.894	0.667		8.596			
Pa	0.500	Kea	γsub	H	H	Panjang											
	0.500	0.368	0.976	8.000	8.000	7.500					86.294	2.667		230.119			
Pw3	2.000	2.000	7.500	0.500				1.000			-15.000	4.670		-70.045			
Pw4	2.000	4.003	7.500					1.000			-60.045	2.002		-120.180			
	5.224	4.003	7.500	0.500				1.000			-78.414	1.334		-104.630			
Pp	0.500	Kep	γsub	H	H	Panjang											
	0.500	2.716	0.976	4.003	3.000	7.500					-119.422	1.334		-159.349			
TOTAL								Σ V	2522.927				Σ Mv	31771.083			
								Σ H		931.299			Σ Mh	6629.394			
Angka keamanan terhadap guling dan geser kondisi gempa : SF Guling = Σ M v / Σ M h = 4,792 > 1.2 Aman SF Geser = ( f · Σ V ) / Σ H = 1,896 > 1.2 Aman																	
Kontrol terhadap eksentrisitas dan daya dukung izin tanah : Eksentrisitas : L = 21,600 m < L / 6 = 3,600 Aman e = 0,835																	
Tegangan maksimum dan minimum yang terjadi di bawah dasar pondasi :																	
f = 0,7      Tegangan izin tanah = 11,49 ton/m <sup>2</sup> Ø = 27,5 °      Tegangan maks = 19,18 ton/m <sup>2</sup> > Tegangan izin tanah, Tidak aman Tegangan min = 11,96 ton/m <sup>2</sup> > Tegangan izin tanah, Tidak aman																	

Sumber: Hasil Perhitungan

Keterangan:

- [ 1 ] = lebar tiap bagian (m)
  - [ 2 ] = tinggi tiap bagian (m)
  - [ 3 ] = panjang konstruksi, tiap 7.5 meter panjang (m)
  - [ 4 ] = 1 digunakan untuk penampang persegi atau persegi panjang  
= 0.5 digunakan untuk penampang segitiga
  - [ 5 ] = berat jenis beton bertulang = 2.4 (t/m<sup>3</sup>)
  - [ 6 ] = gaya vertikal (ton)
  - [ 7 ] = gaya horizontal (ton)
  - [ 8 ] = lengan momen gaya vertikal (m)
  - [ 9 ] = lengan momen gaya horizontal (m)
  - [ 10 ] = momen x (ton.m)
  - [ 11 ] = momen y (ton.m)
- = [ 1 ] \* [ 2 ] \* [ 3 ] \* [ 4 ] \* [ 6 ] (untuk bangunan dan Uplift )  
 nilai (+) untuk arah gaya ke bawah  
 nilai (-) untuk arah gaya ke atas  
 = [ 5 ] \* kh, dengan kh = 0,15 (untuk berat bangunan)  
 = 7/12 \* [ 2 ]<sup>3</sup> \* [ 3 ] \* [ 5 ] \* [ 1 - (hd / [ 2 ])<sup>1.5</sup> ] \* kh (untuk tekanan air dinamis)  
 nilai (+) untuk arah gaya ke hilir  
 nilai (-) untuk arah gaya ke hulu



**Tabel 4.14. Analisis Stabilitas Bangunan Penguras pada Kondisi Muka Air Banjir (Tanpa Gempa)**

Notasi	Nilai				Gaya			Lengan Momen		Momen							
	Lebar (m)	Tinggi (m)	Panjang (m)	Ratio	$\gamma$ (t/m <sup>3</sup> )	Pv (ton)	Ph (ton)	x (m)	y (m)	Mx (ton.m)	My (ton.m)						
	[1]	[2]	[3]	[4]	[5]	[6]	[7]	[8]	[9]	[10]	[11]						
Wc1	12.500	6.000	7.500	x 1,000	2,400	= 1350,000		15,350		20722,500							
Wc5	3.997	3.997	7.500	x 0,500	2,400	= 143,784		7,768		1116,915							
Wc6	3.100	2.003	7.500	x 1,000	2,400	= 111,767		7,550		843,844							
Wc7	2.000	2.000	7.500	x 0,500	2,400	= 36,000		6,667		240,012							
Wc8	6.000	4.003	7.500	x 1,000	2,400	= 432,324		3,000		1296,972							
P1	4.000	6.300	2.500	x 1,000	2,400	= 151,200		13,100		1980,720							
P2	16.497	7.570	2.500	x 1,000	2,400	= 749,294		13,351		10003,821							
P3	3.997	3.997	2.500	x 0,500	2,400	= 47,928		6,435		308,417							
P4	1.503	11.567	2.500	x 1,000	2,400	= 104,311		4,351		453,858							
P5	3.000	11.567	2.500	x 0,500	2,400	= 104,103		2,600		270,668							
PA						60,955		13,100		798,511							
RP						29,875		13,100		391,363							
JK						58,674		7,347		431,074							
Ww1	7.137	6.070	7.500	x 1,000	1,000	= 324,912		18,031		5858,487							
Ww2	3.657	3.657	7.500	x 0,500	1,000	= 50,151		13,244		664,202							
Ww3	9.360	2.413	7.500	x 1,000	1,000	= 169,393		9,783		1657,168							
Ww4	3.997	3.997	7.500	x 0,500	1,000	= 59,910		6,435		385,521							
Ww5	2.840	6.410	7.500	x 1,000	1,000	= 136,533		3,683		502,851							
Ww6	1.662	6.410	7.500	x 0,500	1,000	= 39,950		1,708		68,235							
Pu1	0.500	11.277	7.500		1,000	= -42,291		21,350		-902,903							
Pu2	0.500	0,008	7.500	x 0,500	1,000	= -0,016		21,433		-0,335							
Pu3	13.100	10.258	7.500		1,000	= -1007,852		14,550		-14664,247							
Pu4	13.100	0,219	7.500	x 0,500	1,000	= -10,737		16,733		-179,670							
Pu5	2.000	10.258	7.500		1,000	= -153,871		7,000		-1077,094							
Pu6	2.000	1,867	7.500	x 0,500	1,000	= -13,999		6,667		-93,326							
Pu7	5.500	12,033	7.500		1,000	= -496,353		3,250		-1613,146							
Pu8	5.500	0,092	7.500	x 0,500	1,000	= -1,893		4,167		-7,886							
Pu9	0.500	11.424	7.500		1,000	= -42,839		0,250		-10,710							
Pu10	0.500	0,008	7.500	x 0,500	1,000	= -0,016		0,333		-0,005							
Pw1	6.070	6.070	7.500	x 0,500	1,000	=	138,168		10,023		1384,908						
Pw2	6.070	1,000	7.500	x	1,000	=	45,525		7,500		341,438						
Pw3	0.483	1,000	7.500	x 0,500	1,000	=	1,810		7,333		13,276						
Pw4	6.553	1,000	7.500	x	1,000	=	49,146		6,500		319,448						
Pw5	0.950	1,000	7.500	x 0,500	1,000	=	3,562		6,333		22,561						
Pw6	7.503	1,000	7.500	x	1,000	=	56,270		5,500		309,487						
Pw7	0.933	1,000	7.500	x 0,500	1,000	=	3,500		5,333		18,665						
Pw8	8.436	3,000	7.500	x	1,000	=	189,810		3,500		664,333						
Pw9	2.850	3,000	7.500	x 0,500	1,000	=	32,061		3,000		96,182						
Pw10	10.258	2,000	7.500	x	1,000	=	153,871		1,000		153,871						
Pw11	1.867	2,000	7.500	x 0,500	1,000	=	13,999		0,667		9,333						
Pa	0.500	Ka	γsub	x H	x H	x Panjang											
Pb	0.500	0,368	0,976	x 8,000	x 8,000	x 7,500		86,294		2,667		230,119					
Pw7	6.410	6.410	7.500	x 0,500	1,000	=	-154,080		6,140		-946,002						
Pw8	6.410	4.003	7.500		1,000	=	-192,444		2,002		-385,177						
Pw9	4.317	4.003	7.500	x 0,500	1,000	=	-64,799		1,334		-86,463						
Pp	0.500	Kp	γsub	x H	x H	x Panjang											
Pq	0.500	2,716	0,976	x 4,003	x 4,000	x 7,500		-159,230		1,334		-212,465					
<b>TOTAL</b>					<b>Σ V</b>	<b>2391,199</b>			<b>Σ Mv</b>	<b>29445,815</b>			<b>Σ H</b>	<b>203,463</b>		<b>Σ Mh</b>	<b>1750,948</b>
Angka keamanan terhadap guling dan geser kondisi tanpa gempa :																	
SF Guling = $\Sigma Mv / \Sigma Mh$ =							16,82	>	1,5	Aman							
SF Geser = $(f \cdot \Sigma V) / \Sigma H$ =							8,23	>	1,5	Aman							
Kontrol terhadap eksentrisitas dan daya dukung izin tanah :																	
Eksentrisitas :																	
L =	21,600	m						L / 6 =	3,600	Aman							
e =	0,782	<															
Tegangan maksimum dan minimum yang terjadi di bawah dasar pondasi :																	
Tegangan izin tanah =	11,493	ton/m <sup>2</sup>															
Tegangan maks =	17,967	ton/m <sup>2</sup>	>	Tegangan izin tanah, Tidak aman													
Tegangan min =	11,554	ton/m <sup>2</sup>	>	Tegangan izin tanah, Tidak aman													

Sumber: Hasil Perhitungan

Keterangan:

- [1] = lebar tiap bagian (m)  
 [2] = tinggi tiap bagian (m)  
 [3] = panjang konstruksi, tiap 7,5 meter panjang (m)  
 [4] = 1 digunakan untuk penampang persegi atau persegi panjang  
 = 0,5 digunakan untuk penampang segitiga  
 [5] = berat jenis beton bertulang = 2,4 (t/m<sup>3</sup>)  
 = berat jenis air = 1,0 (t/m<sup>3</sup>)  
 [6] = gaya vertikal (ton)  
 = [1] \* [2] \* [3] \* [4] \* [5] (untuk bangunan dan Uplift)  
 nilai (+) untuk arah gaya ke bawah  
 nilai (-) untuk arah gaya ke atas
- [7] = gaya horizontal (ton)  
 = [5] \* kh, dengan kh = 0,15 (untuk berat bangunan)  
 =  $7/12 * [2]^2 * [3] * [5] * [1 - (hd/[2])^{1.5}]$  \* kh (untuk tekanan air dinamis)  
 nilai (+) untuk arah gaya ke hilir  
 nilai (-) untuk arah gaya ke hulu  
 [8] = lengan momen gaya vertikal (m)  
 [9] = lengan momen gaya horizontal (m)  
 [10] = momen x (ton.m)  
 = [7] \* [9]  
 [11] = momen y (ton.m)  
 = [8] \* [10]



Tabel 4.15. Analisis Stabilitas Bangunan Penguras pada Kondisi Muka Air Banjir (Gempa)

Table with 13 columns: Notasi, Lebar (m), Tinggi (m), Panjang (m), Ratio, Nilai, γ (t/m³), Gaya (Pv, Ph), Lengan Momen (x, y), and Momen (Mx, My). It lists various structural elements like Wc1, Wcs, P1, Pa, Pw1, etc., and includes a 'TOTAL' row at the bottom. Below the table are calculations for safety factors (SF Guling, SF Geser) and eccentricity (Eksentrisitas).

Sumber: Hasil Perhitungan

Keterangan:

- [1] = lebar tiap bagian (m) [7] = gaya horizontal (ton)
[2] = tinggi tiap bagian (m) [8] = [ 5 ] \* kh , dengan kh = 0,15 (untuk berat bangunan)
[3] = panjang konstruksi, tiap 7,5 meter panjang (m) [9] = 7/12 \* [ 2 ]² \* [ 3 ] \* [ 5 ] \* [ 1 - (hd/ [ 2 ] )¹.⁵ ] \* kh (untuk tekanan air dinamis)
[4] = 1 digunakan untuk penampang persegi atau persegi panjang nilai (+) untuk arah gaya ke hilir
[5] = 0,5 digunakan untuk penampang segitiga nilai (-) untuk arah gaya ke hulu
[6] = berat jenis beton bertulang = 2,4 (t/m³) [10] = lengan momen gaya vertikal (m)
[7] = berat jenis air = 1,0 (t/m³) [11] = lengan momen gaya horizontal (m)
[8] = gaya vertikal (ton) [9] = momen x (ton.m)
[10] = [ 1 ] \* [ 2 ] \* [ 3 ] \* [ 4 ] \* [ 6 ] (untuk bangunan dan Uplift ) = [ 7 ] \* [ 9 ]
[11] = [ 1 ] \* [ 2 ] \* [ 3 ] \* [ 4 ] \* [ 6 ] (untuk bangunan dan Uplift ) = [ 8 ] \* [ 10 ]
nilai (+) untuk arah gaya ke bawah
nilai (-) untuk arah gaya ke atas

Tabel 4.16. Rekapitulasi Perhitungan Stabilitas Bangunan Penguras (*Sluice Gate*)

No.	Tinjauan analisa stabilitas	Angka keamanan terhadap guling		Angka keamanan terhadap geser		Eksentrisitas	L/6	Kontrol Eksentrisitas	Tegangan maks	Tegangan min	Tegangan izin	Kontrol Daya dukung
		SF Guling		SF Geser								
<b>A</b>	<b>Tinjauan Kondisi Tanpa Gempa</b>	SF > 1,5		SF > 1,5				$e \leq L/6$				< $\sigma$ izin
1	Muka Air Normal	12,08	Aman	4,86	Aman	0,751	3,600	Aman	18,821	12,327	11,493	Tidak Aman
2	Muka Air Banjir	16,82	Aman	8,23	Aman	0,782	3,600	Aman	17,967	11,554	11,493	Tidak Aman
<b>B</b>	<b>Tinjauan Kondisi Gempa</b>	SF > 1,2		SF > 1,2				$e \leq L/6$				< $\sigma$ izin
1	Muka Air Normal	4,79	Aman	1,90	Aman	0,835	3,600	Aman	19,185	11,963	11,493	Tidak Aman
2	Muka Air Banjir	4,98	Aman	2,28	Aman	0,958	3,600	Aman	18,687	10,834	11,493	Tidak Aman

Sumber: Hasil Perhitungan

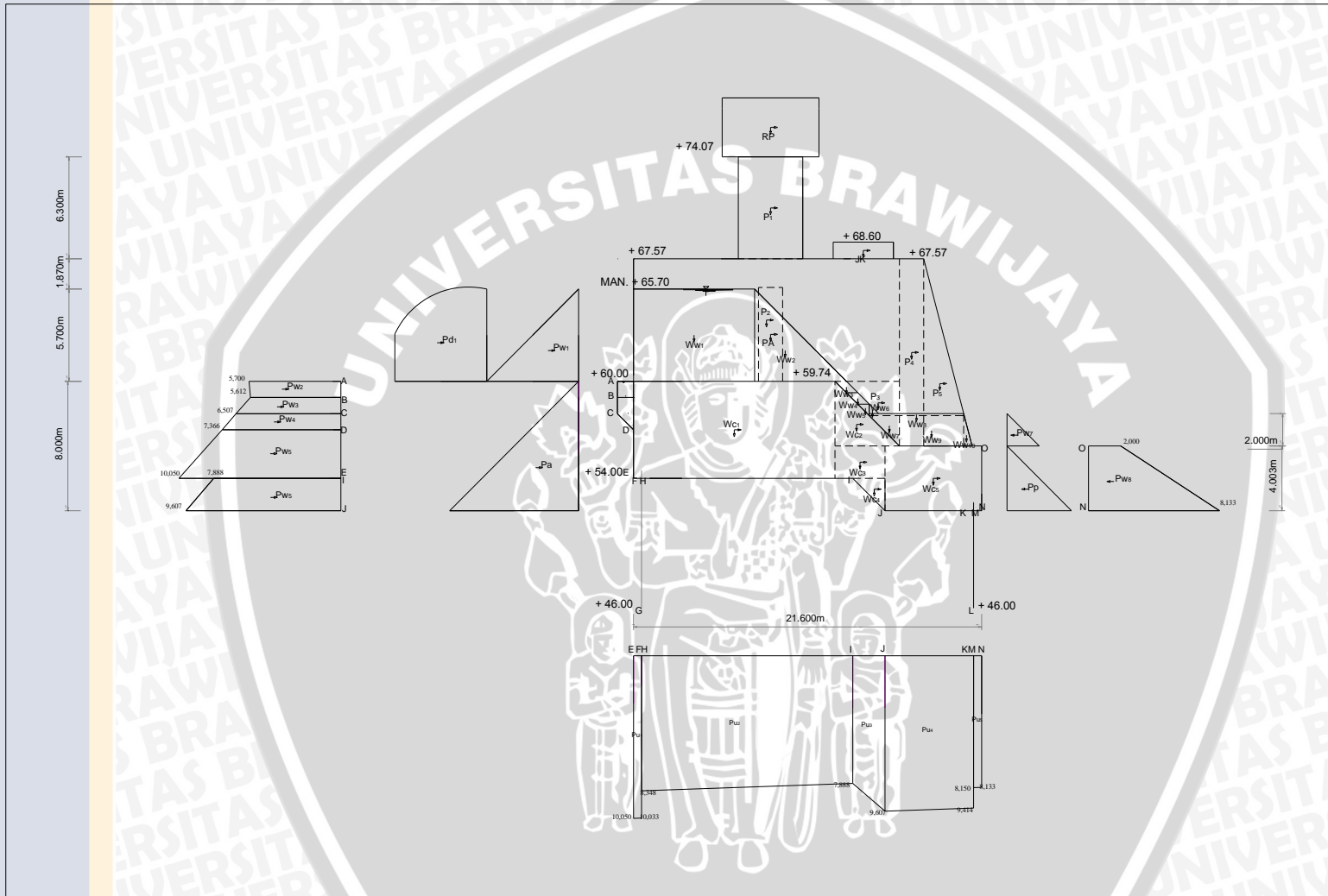

Gambar 4.14. Diagram Gaya Pada Bangunan Penguras (*Sluice Gate*) pada Kondisi Muka Air Normal

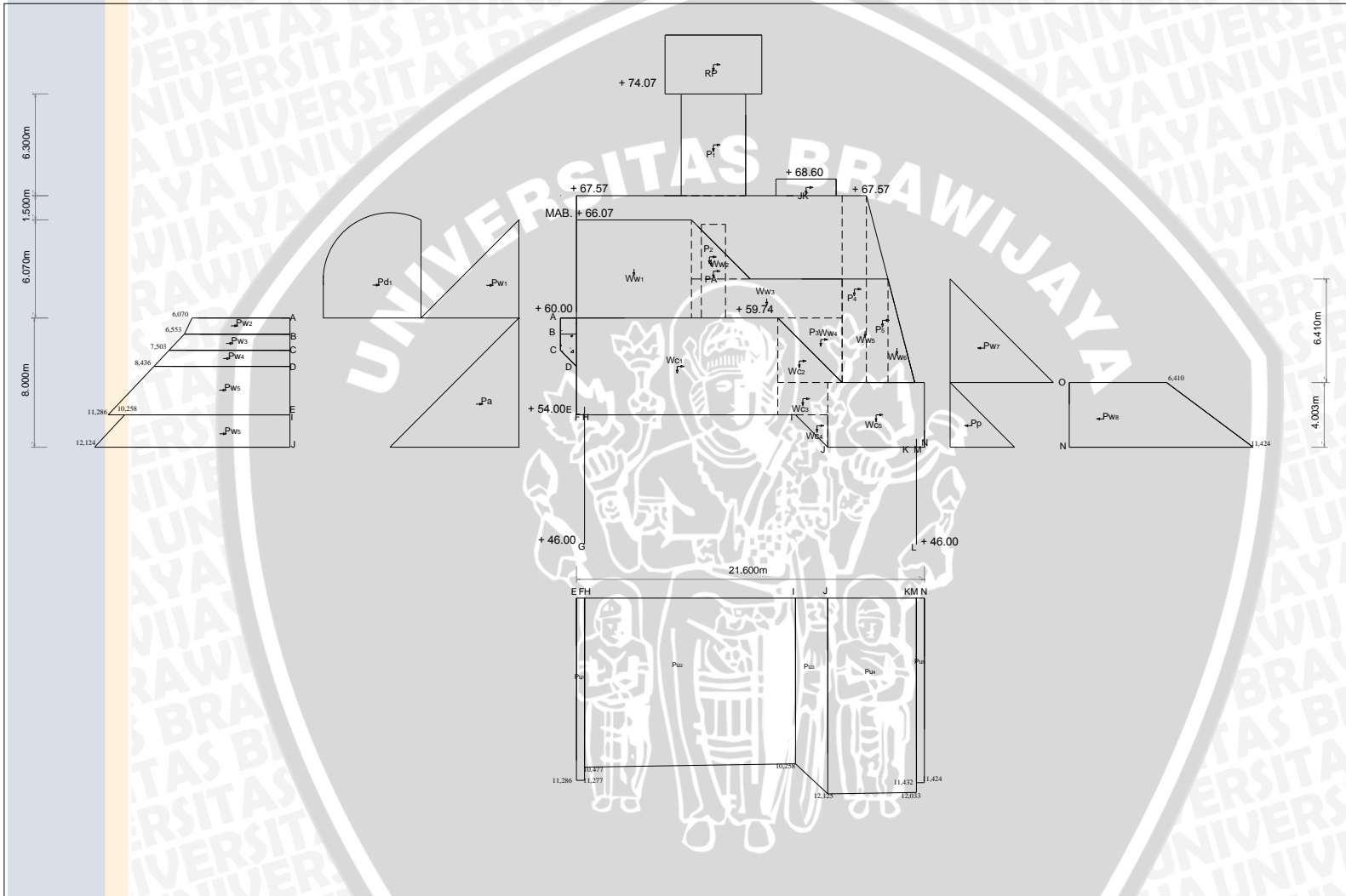

Gambar 4.15. Diagram Gaya Pada Bangunan Penguras (*Sluice Gate*) pada Kondisi Muka Air Banjir

#### 4.3.3. Dinding Penahan Tanah Bagian Hulu

Dalam perencanaan stabilitas konstruksi bangunan perlu dilakukan anggapan atau asumsi keadaan tanpa gempa dan gempa. Adapun setiap keadaan tersebut, dinding penahan tanah bagian hulu masih perlu diadakan tinjauan dengan 4 kondisi yaitu :

1. Kondisi I : saat muka air normal (tanpa gempa)
2. Kondisi III : saat muka air normal (gempa)
3. Kondisi IV : saat muka air banjir  $Q_{PMF}$  (tanpa gempa)
4. Kondisi VI : saat muka air banjir  $Q_{PMF}$  (gempa)

Perhitungan stabilitas dinding penahan dilakukan dengan kondisi gaya. pembebanan yang bekerja pada bangunan dinding penahan adalah sebagai berikut:

1. Beban vertikal
  - a) Gaya berat dinding penahan
  - b) Beban kendaraan ( $q = 1 \text{ t/m}^2$ )
2. Tekanan air (statis dan dinamis)
3. Tekanan tanah (aktif dan pasif)
4. Gaya angkat (*uplift*)

Beberapa perhitungan stabilitas pada dinding penahan dalam keadaan muka air normal dan muka air banjir ( $Q_{pmf}$ ) dijabarkan pembebanannya untuk mengetahui beban-beban apa saja yang terjadi pada bangunan.

Gaya berat dari dinding penahan disesuaikan dengan dimensi dari bangunan tersebut. Untuk mempermudah dalam perhitungan beban vertikal maka bangunan perlu dibagi menjadi bagian-bagian kecil yang disajikan secara visual seperti pada Gambar 4.16. dan Gambar 4.17. Perhitungan gaya berat pada dinding penahan tanah menggunakan persamaan (2-12) dapat dilihat pada Tabel 4.17.

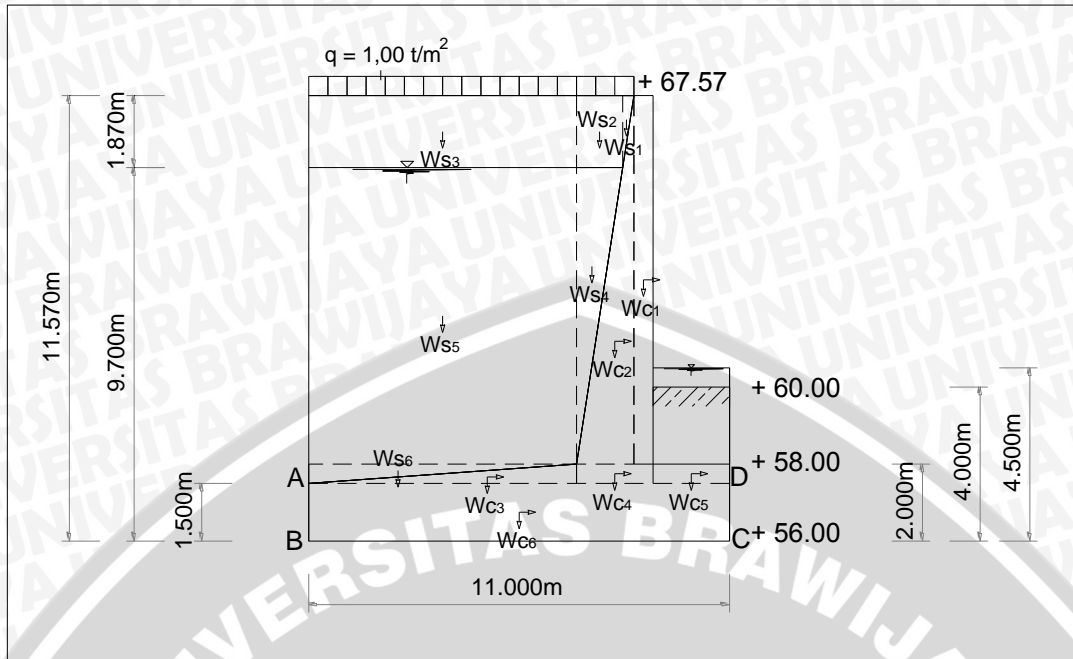

**Gambar 4.16. Gaya Berat pada Dinding Penahan Tanah Bagian Hulu Kondisi Muka Air Normal**

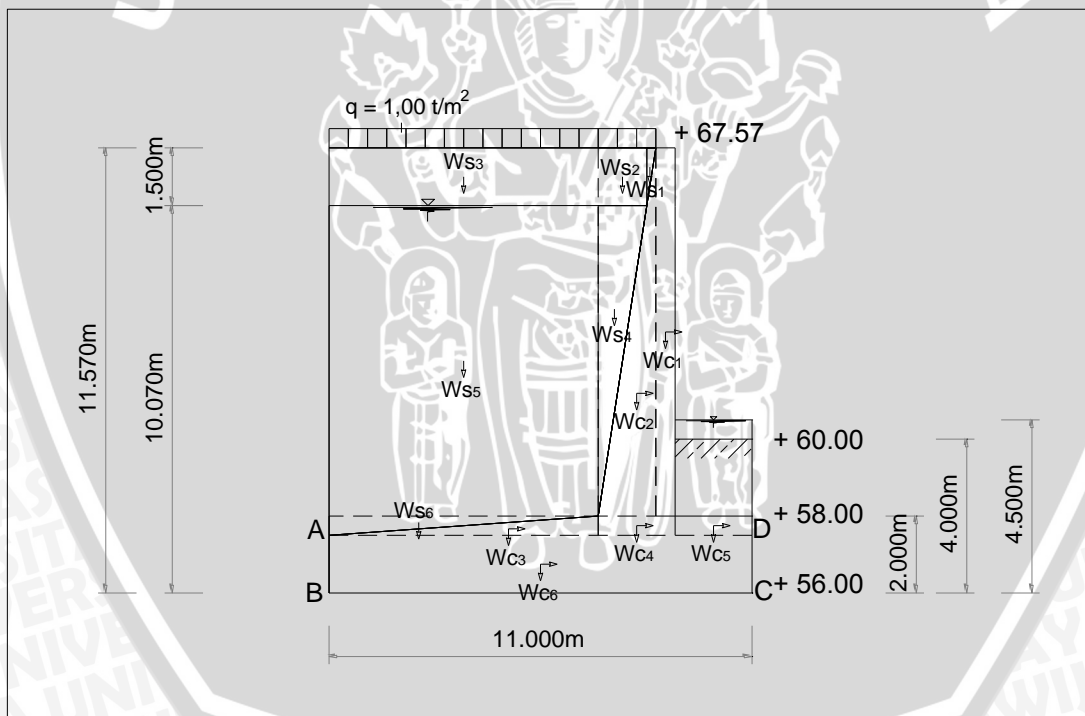

**Gambar 4.17. Gaya Berat pada Dinding Penahan Tanah Bagian Hulu Kondisi Muka Air Banjir**

**Tabel 4.17. Perhitungan Gaya Berat pada Dinding Penahan Tanah Bagian Hulu**

Notasi	Nilai				Volume	$\gamma$	Gaya Berat
	Lebar	Tinggi	Panjang	Ratio			
	m	m	m	m	$m^3$	$(t/m^3)$	(t)
	[ 1 ]	[ 2 ]	[ 3 ]	[ 4 ]	[ 5 ]	[ 6 ]	[ 7 ]
Wc1	0,500	9,570	1,000	1,000	4,785	2,400	11,484
Wc2	1,500	9,570	1,000	0,500	7,178	2,400	17,226
Wc3	7,000	0,500	1,000	0,500	1,750	2,400	4,200
Wc4	2,000	0,500	1,000	1,000	1,000	2,400	2,400
Wc5	2,000	0,500	1,000	1,000	1,000	2,400	2,400
Wc6	11,000	1,500	1,000	1,000	16,500	2,400	39,600
Total							77,310

Sumber: Hasil Perhitungan

Keterangan:

[ 1 ] = lebar tiap bagian (m)

[ 2 ] = tinggi tiap bagian (m)

[ 3 ] = panjang konstruksi, tiap 1 meter panjang (m)

[ 4 ] = 1 digunakan untuk penampang persegi atau persegi panjang  
= 0,5 digunakan untuk penampang segitiga

[ 5 ] = volume ( $m^3$ )  
= [ 1 ] \* [ 2 ] \* [ 3 ] \* [ 4 ]

[ 6 ] = berat jenis beton bertulang = 2,4 ( $t/m^3$ )

[ 7 ] = gaya berat konstruksi (ton)  
= [ 5 ] \* [ 6 ]

Gaya berat yang dipengaruhi oleh gempa dapat menimbulkan gaya yang bekerja ke arah horizontal. Besarnya gaya horizontal ini didapatkan dengan cara perkalian antara berat vertikal dengan koefisien gempa, dimana nilai koefisien gempa pada daerah studi ini adalah 0,15.

Tekanan air menimbulkan gaya horizontal yang berpengaruh terhadap pembebanan dinding penahan tanah. Salah satu tekanan air yang terdapat pada kondisi tersebut adalah sebagai berikut:

$$\begin{aligned}
 Pw_1 &= \frac{1}{2} \cdot H^2 \times \text{panjang} \times \gamma_w \\
 &= \frac{1}{2} \times (9,700)^2 \times 1,000 \times 1,000 \\
 &= 47,045 \text{ ton}
 \end{aligned}$$

Tekanan tanah yang dialami oleh bangunan berupa tekanan tanah aktif dan tekanan tanah pasif. Dimana koefisien tekanan tanah aktif dan pasif dihitung menggunakan persamaan berikut:

Tekanan Tanah aktif:

- $\emptyset = 30,00^\circ$
- $\beta = 0,00^\circ$
- $\theta = 8,91^\circ$
- $\delta = 0,00^\circ$
- $\Psi = \tan^{-1} \left( \frac{kh}{1-kv} \right) = \tan^{-1} \left( \frac{0,15}{1-0} \right) = 8,53^\circ$

$$\begin{aligned}
 K_a &= \frac{\cos^2(\emptyset - \theta)}{\cos^2 \emptyset \cdot \cos(\theta + \delta) \left[ 1 + \frac{\sin(\emptyset + \delta) \cdot \sin(\emptyset - \beta)}{\cos(\delta + \theta) \cdot \cos(\beta - \theta)} \right]^2} \\
 &= \frac{\cos^2(30,00 - 8,91)}{\cos^2 8,91 \cdot \cos(8,91 + 0,00) \left[ 1 + \frac{\sin(30,00 + 0,00) \cdot \sin(30,00 - 0,00)}{\cos(0,00 + 8,91) \cdot \cos(0,00 - 8,91)} \right]^2} \\
 &= \frac{0,870}{2,187} \\
 &= 0,398
 \end{aligned}$$

$$\begin{aligned}
 K_{ae} &= \frac{\cos^2(\emptyset - \theta - \Psi)}{\cos \Psi \cdot \cos^2 \emptyset \cdot \cos(\theta + \delta + \Psi) \left[ 1 + \frac{\sin(\emptyset + \delta) \cdot \sin(\emptyset - \beta - \Psi)}{\cos(\delta + \theta + \Psi) \cdot \cos(\beta - \theta)} \right]^2} \\
 &= \frac{\cos^2(30,00 - 8,91 - 8,53)}{\cos 8,53 \cdot \cos^2 8,91 \cdot \cos(8,91 + 0,00 + 8,53) \left[ 1 + \frac{\sin(30,00 + 0,00) \cdot \sin(30,00 - 0,00 - 8,53)}{\cos(0,00 + 8,91 + 8,53) \cdot \cos(0,00 - 8,91)} \right]^2} \\
 &= \frac{0,866}{2,124} \\
 &= 0,408
 \end{aligned}$$

Tekanan Tanah pasif:

$$\begin{aligned}
 K_p &= \frac{\cos^2(\emptyset + \theta)}{\cos^2 \emptyset \cdot \cos 2(\delta - \theta) \left[ 1 + \frac{\sin(\emptyset + \delta) \cdot \sin(\emptyset + \beta)}{\cos(\delta - \theta) \cdot \cos(\beta - \theta)} \right]^2} \\
 &= \frac{\cos^2(30,00 + 8,91)}{\cos^2 8,91 \cdot \cos(0,00 - 8,91) \left[ 1 + \frac{\sin(30,00 + 0,00) \cdot \sin(30,00 + 0,00)}{\cos(0,00 - 8,91) \cdot \cos(0,00 - 8,91)} \right]^2} \\
 &= \frac{0,606}{0,235} \\
 &= 2,574
 \end{aligned}$$



$$\begin{aligned}
 \text{Kep} &= \frac{\cos^2(\theta + \Psi)}{\cos \Psi \cdot \cos^2 \theta \cdot \cos(\delta - \theta + \Psi) \left[ 1 - \frac{\sin(\theta + \delta) \cdot \sin(\theta + \beta - \Psi)}{\cos(\delta - \theta + \Psi) \cdot \cos(\beta - \theta)} \right]^2} \\
 &= \frac{\cos^2(30,00 + 8,91 - 8,53)}{\cos 8,53 \cdot \cos^2 8,91 \cdot \cos(0,00 - 8,91 + 8,53) \left[ 1 - \frac{\sin(30,00 + 0,00) \cdot \sin(30,00 + 0,00 - 8,53)}{\cos(0,00 - 8,91 + 8,53) \cdot \cos(0,00 - 8,91)} \right]^2} \\
 &= \frac{0,8660}{0,569} \\
 &= 1,536
 \end{aligned}$$

Perhitungan tekanan tanah aktif adalah sebagai berikut:

dimana:

- $\gamma_{\text{tanah}} = 1,80 \text{ t/m}^2$
- $G_s = 2,66$
- $e = 0,70$
- $\gamma_{\text{sat}} = \frac{\gamma_w(G_s + e)}{1 + e}$ , (dengan  $S_r = 1$ )  
 $= \frac{1,0(2,66 + 0,7)}{1 + 0,7} = 1,976 \text{ t/m}^2$
- $\gamma_{\text{sub}} = \gamma_{\text{sat}} - \gamma_w$   
 $= 1,976 - 1,000$   
 $= 0,976 \text{ t/m}^2$
- $h_1 = 1,870 \text{ m}$
- $h_2 = 9,700 \text{ m}$
- $h_3 = 4,000 \text{ m}$
- $h_4 = 4,500 \text{ m}$

$$\begin{aligned}
 Pa_1 &= K_a \cdot q \cdot h_1 \\
 &= 0,398 \cdot 1,000 \cdot 1,870 \\
 &= 0,744 \text{ ton}
 \end{aligned}$$

$$\begin{aligned}
 Pa_2 &= \frac{1}{2} \cdot K_a \cdot h_1^2 \cdot \gamma \\
 &= \frac{1}{2} \cdot 0,398 \cdot (1,870)^2 \cdot 1,800 \\
 &= 1,253 \text{ ton}
 \end{aligned}$$

$$\begin{aligned}
 Pa_3 &= (K_a \cdot q + K_a \cdot h_1 \cdot \gamma) h_2 \\
 &= (0,398 \cdot 1,000 + 0,398 \cdot 1,870 \cdot 1,800) 9,700 \\
 &= 16,855 \text{ ton}
 \end{aligned}$$

$$\begin{aligned}
 Pa_4 &= \frac{1}{2} \cdot Ka \cdot h_2^2 \cdot \gamma_{\text{sub}} \\
 &= \frac{1}{2} \cdot 0,398 \cdot (9,700)^2 \cdot 0,976 \\
 &= 18,283 \text{ ton}
 \end{aligned}$$

Perhitungan tekanan tanah pasif adalah sebagai berikut:

$$\begin{aligned}
 Pp &= \frac{1}{2} \cdot Kp \cdot \gamma_{\text{sub}} \cdot h_3^2 \cdot \text{Panjang} \\
 &= \frac{1}{2} \cdot 2,574 \cdot 0,976 \cdot (4,000)^2 \cdot (1,000) \\
 &= -20,110 \text{ ton}
 \end{aligned}$$

Gaya angkat (*uplift*) terjadi disebabkan oleh perbedaan elevasi muka air hulu dan hilir yang bekerja pada dasar pondasi. Bangunan yang terendam air akan mendapatkan gaya angkat ke atas yang akan mengurangi berat efektif bangunan itu sendiri. Perhitungan gaya angkat (*uplift*) adalah sebagai berikut:

$$\begin{aligned}
 Pu_1 &= \text{lebar} \times \text{tinggi uplift} \times \text{panjang} \times \gamma_{\text{air}} \\
 &= 11,000 \times 5,951 \times 1,000 \times 1,000 \\
 &= -65,463 \text{ ton}
 \end{aligned}$$

Perhitungan *uplift* pada kondisi normal maupun pada kondisi banjir disajikan pada Tabel 4.18 dan 4.19.

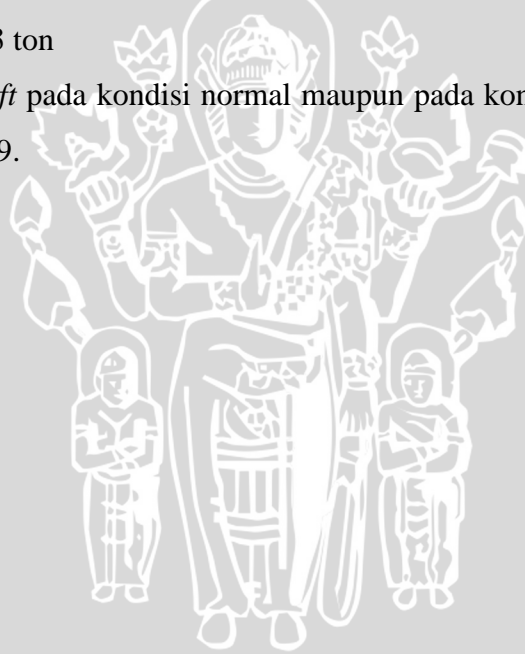

**Tabel 4.18. Perhitungan Gaya Uplift tiap titik pada Dinding Penahan Tanah Kondisi Muka Air Normal**

Panjang Creep = 7,167  
 Tinggi air di hulu = 9,700  
 Tinggi air di hilir = 4,500

Titik	Garis	Panjang Rembesan				$\Delta H$	Hx	Uplift
		Vertikal	Horizont al	1/3.Horiz ontal	Jarak			
		[ 1 ]	[ 2 ]	[ 3 ]	[ 4 ]			
A					0,000	0,000	8,200	8,200
	A-B	1,500						
B					1,500	1,088	9,700	8,612
	B-C		11,000	3,667				
C					5,167	3,749	9,700	5,951
	C-D	2,000						
D					7,167	5,200	7,700	2,500

Sumber: Hasil Perhitungan

$$\begin{aligned}
 C_w (\text{Lane}) &= \frac{L_w}{H_w} \\
 &= \frac{7,167}{5,200} \\
 &= 1,378
 \end{aligned}$$

Keterangan:

- [ 1 ] = panjang rembesan vertikal tiap garis (m)  
 [ 2 ] = panjang rembesan horizontal tiap garis (m)  
 [ 3 ] = [ 2 ] \* 1/3  
 [ 4 ] = jarak komulatif di tiap titik (m)  
 = [ 1 ]<sub>n</sub> + [ 3 ]<sub>n-1</sub>  
 [ 5 ] = pengurangan tekanan air (t/m)  
 =  $L_w/C_w$   
 [ 6 ] = jarak muka air ke titik x (t/m)  
 [ 7 ] = gaya uplift (t/m)  
 = [ 6 ] - [ 5 ]

$$\begin{aligned}
 H_w &= \text{Tinggi Energi hulu} - \text{tinggi energi di hilir} \\
 &= 5,200
 \end{aligned}$$

**Tabel 4.19. Perhitungan Gaya Uplift tiap titik pada Dinding Penahan Tanah Kondisi Muka Air Banjir**

Panjang Creep = 7,167  
 Tinggi air di hulu = 10,070  
 Tinggi air di hilir = 4,500

Titik	Garis	Panjang Rembesan				$\Delta H$	Hx	Uplift
		Vertikal	Horizont al	1/3.Horiz ontal	Jarak			
		[ 1 ]	[ 2 ]	[ 3 ]	[ 4 ]			
A					0,000	0,000	8,570	8,570
B	A-B	1,500			1,500	1,166	10,070	8,904
C	B-C		11,000	3,667	5,167	4,016	10,070	6,054
D	C-D	2,000			7,167	5,570	8,070	2,500

Sumber: Hasil Perhitungan

$$\begin{aligned}
 Cw \text{ (Lane)} &= \frac{Lw}{Hw} \\
 &= \frac{7,167}{5,570} \\
 &= 1,287
 \end{aligned}$$

Keterangan:

Keterangan:

- [ 1 ] = panjang rembesan vertikal tiap garis (m)  
 [ 2 ] = panjang rembesan horizontal tiap garis (m)  
 [ 3 ] = [ 2 ] \* 1/3  
 [ 4 ] = jarak kumulatif di tiap titik (m)  
 = [ 1 ]<sub>n</sub> + [ 3 ]<sub>n-1</sub>  
 [ 5 ] = pengurangan tekanan air (t/m)  
 = Lw/Cw  
 [ 6 ] = jarak muka air ke titik x (t/m)  
 [ 7 ] = gaya uplift (t/m)  
 = [ 6 ] - [ 5 ]

$$\begin{aligned}
 Hw &= \text{Tinggi Energi hulu} - \text{tinggi energi di hilir} \\
 &= 5,570
 \end{aligned}$$

Analisis stabilitas konstruksi untuk kondisi normal dapat dilihat dari nilai stabilitas geser, stabilitas guling, eksentrisitas dan daya dukung. Perhitungan nilai eksentrisitas sesuai dengan persamaan (2-4) dan perhitungan daya dukung adalah sebagai berikut:

1. Stabilitas terhadap Guling:

$$\begin{aligned} SF &= \frac{M_v}{M_h} \\ &= \frac{982,592}{271,816} \\ &= 3,61 \end{aligned}$$

Syarat stabilitas terhadap guling:

$$\begin{aligned} SF &> 1,5 \quad (\text{SF dalam keadaan normal}) \\ \text{maka, } 3,61 &> 1,5 \quad \dots\dots\dots \text{memenuhi syarat} \end{aligned}$$

2. Stabilitas terhadap Geser:

Dengan:  $f = 0,7$

$$\begin{aligned} SF &= \frac{\sum V \cdot f}{\sum H} \\ &= \frac{153,803 \cdot 0,7}{53,944} \\ &= 1,99 \end{aligned}$$

Syarat stabilitas terhadap guling:

$$\begin{aligned} SF &> 1,5 \quad (\text{SF dalam keadaan gempa}) \\ \text{maka } 1,99 &> 1,5 \quad \dots\dots\dots \text{memenuhi syarat} \end{aligned}$$

3. Nilai eksentrisitas:

$$\begin{aligned} e &= \left| \frac{\sum M_v - \sum M_h}{\sum V} - \frac{B}{2} \right| \\ &= \left| \frac{982,592 - 271,816}{153,008} - \frac{11,00}{2} \right| \\ &= 0,855 \end{aligned}$$

Syarat eksentrisitas:

$$\begin{aligned} e &\leq \frac{B}{6} \\ \text{maka, } e &\leq \frac{11,000}{6} \\ 0,855 &\leq 1,833 \quad \dots\dots\dots \text{memenuhi syarat} \end{aligned}$$

## 4. Daya Dukung:

$$\begin{aligned}\sigma_{\max} &= \frac{\Sigma V}{A} \left(1 + \frac{6 \cdot e}{B}\right) \\ &= \frac{153,008}{11,000 \times 1,000} \left(1 + \frac{6 \cdot 0,855}{11,000}\right) \\ &= 20,33 \text{ t/m}^2 \\ \sigma_{\min} &= \frac{\Sigma V}{A} \left(1 - \frac{6 \cdot e}{B}\right) \\ &= \frac{153,008}{11,000 \times 1,000} \left(1 - \frac{6 \cdot 0,855}{11,000}\right) \\ &= 7,43 \text{ t/m}^2\end{aligned}$$

Syarat daya dukung:

$$\begin{aligned}\sigma_{\max} \text{ dan } \sigma_{\min} &< \text{ Daya dukung izin tanah} \\ \sigma_{\max} = 20,33 \text{ t/m}^2 &> 18,26 \text{ ton/m}^2 \text{ ..... tidak memenuhi syarat} \\ \sigma_{\min} = 7,43 \text{ t/m}^2 &> 18,26 \text{ ton/m}^2 \text{ ..... memenuhi syarat}\end{aligned}$$

Pada perhitungan di atas dapat dilihat bahwa tegangan yang terjadi pada konstruksi melebihi daya dukung izin tanah sehingga diperlukan satu perlakuan untuk mengatasi masalah tersebut, yaitu dengan menggunakan alternatif berupa pondasi tiang pancang.

Perhitungan analisis stabilitas pada berbagai kondisi disajikan pada Tabel 4.20 sampai dengan Tabel 4.23. Diagram gaya yang bekerja pada dinding penahan tanah sesuai dengan kondisi yang dianalisis disajikan pada Gambar 4.18. sampai dengan Gambar 4.21. Rekapitulasi hasil perhitungan stabilitas dinding penahan bagian hulu dengan berbagai kondisi yang telah dianalisis pada halaman sebelumnya, disajikan pada Tabel 4.24.

**Tabel 4.20. Analisis Stabilitas Dinding Penahan Hulu Kondisi Muka Air Normal (Tanpa Gempa)**

Notasi	Nilai						Gaya		Lengan Momen		Momen		
	Lebar (m)	Tinggi (m)	Panjang (m)	Ratio			$\gamma$ (t/m <sup>3</sup> )	Pv (ton)	Ph (ton)	x (m)	y (m)	Mx (ton.m)	My (ton.m)
	[1]	[2]	[3]	[4]			[5]	[6]	[7]	[8]	[9]	[10]	[11]
Wc1	0,500	x	9,570	x	1,000	x	1,000						
Wc2	1,500	x	9,570	x	1,000	x	0,500						
Wc3	7,000	x	0,500	x	1,000	x	0,500						
Wc4	2,000	x	0,500	x	1,000	x	1,000						
Wc5	2,000	x	0,500	x	1,000	x	1,000						
Wc6	11,000	x	1,500	x	1,000	x	1,000						
Ws1	0,293	x	1,870	x	1,000	x	0,500						
Ws2	1,207	x	1,870	x	1,000	x	1,000						
Ws3	7,000	x	1,870	x	1,000	x	1,000						
Ws4	1,207	x	7,700	x	1,000	x	0,500						
Ws5	7,000	x	7,700	x	1,000	x	1,000						
Ws6	7,000	x	0,500	x	1,000	x	0,500						
q	8,500	x	1,000										
Pu1	11,000	x	5,951	x	1,000								
	11,000	x	2,660	x	1,000	x	0,500						
Pa1	Ka	x	q	x	h <sub>1</sub>								
	0,398	x	1,000	x	1,870								
Pa2	Ka	x	0,5	x	h <sub>1</sub>	x	h <sub>1</sub>	x	v				
	0,398	x	0,500	x	1,870	x	1,870	x	1,800				
Pa3	(Ka	x	q	+ Ka	x	v	x	h <sub>1</sub> )	x	h <sub>2</sub>			
	(0,398	x	1,000	+ 0,398	x	1,800	x	1,870)	x	9,700			
Pa4	Ka	x	0,5	x	h <sub>2</sub>	x	h <sub>2</sub>	x	ysub				
	0,398	x	0,500	x	9,700	x	9,700	x	0,976				
Pw1	0,500	x	h <sub>2</sub>	x	h <sub>2</sub>								
	0,500	x	9,700	x	9,700								
Pp	Kp	x	0,500	x	h <sub>2</sub>	x	h <sub>2</sub>	x	ysub				
	2,574	x	0,500	x	4,000	x	4,000	x	0,976				
Pw3	0,500	x	h <sub>1</sub>	x	h <sub>1</sub>								
	0,500	x	4,500	x	4,500								
<b>TOTAL</b>								<b>Σ V</b>	<b>153,008</b>			<b>Σ Mv</b>	<b>982,592</b>
								<b>Σ H</b>	<b>53,944</b>			<b>Σ Mh</b>	<b>271,816</b>
Angka keamanan terhadap guling dan geser kondisi tanpa gempa :													
SF Guling = $\Sigma M v / \Sigma M h =$									3,61			> 1,5 Aman	
SF Geser = $(f \cdot \Sigma V) / \Sigma H =$									1,99			> 1,5 Aman	
Kontrol terhadap eksentrisitas dan daya dukung izin tanah :													
Eksentrisitas :													
L = 11,000 m													
e = 0,855													
f = 0,70													
Ø = 27,5 °													
Tegangan maksimum dan minimum yang terjadi di bawah dasar pondasi :													
Tegangan izin tanah =									18,26	ton/m <sup>2</sup>			
Tegangan maks =									20,39	ton/m <sup>2</sup>		> Tegangan izin tanah, Tidak aman	
Tegangan min =									7,43	ton/m <sup>2</sup>		< Tegangan izin tanah , Aman	

Sumber: Hasil Perhitungan

Keterangan:

- [ 1 ] = lebar tiap bagian (m)
- [ 2 ] = tinggi tiap bagian (m)
- [ 3 ] = panjang konstruksi, tiap 1 meter panjang (m)
- [ 4 ] = 1 digunakan untuk penampang persegi atau persegi panjang  
= 0,5 digunakan untuk penampang segitiga
- [ 5 ] = berat jenis beton bertulang = 2,4 (t/m<sup>3</sup>)  
= berat jenis tanah timbunan = 1,8 (t/m<sup>3</sup>)  
= berat jenis tanah jenuh = 1,976 (t/m<sup>3</sup>)  
= berat jenis air = 1,000 (t/m<sup>3</sup>)
- [ 6 ] = gaya vertikal (ton)  
= [ 1 ] \* [ 2 ] \* [ 3 ] \* [ 4 ] \* [ 5 ]  
(untuk bangunan, timbunan dan uplift)  
nilai (+) untuk arah gaya ke bawah  
nilai (-) untuk arah gaya ke atas
- [ 7 ] = gaya horizontal (ton)  
= [ 6 ] \* kh , dengan kh = 0,15 (untuk berat bangunan)  
= 7/12 \* [ 2 ]<sup>2</sup> \* [ 5 ] \* kh (untuk tekanan air dinamis)  
nilai (+) untuk arah gaya ke hilir  
nilai (-) untuk arah gaya ke hulu
- [ 8 ] = lengan momen gaya vertikal (m)
- [ 9 ] = lengan momen gaya horizontal (m)
- [ 10 ] = momen (ton.m)  
= [ 6 ] \* [ 8 ]
- [ 11 ] = momen (ton.m)  
= [ 7 ] \* [ 9 ]



**Tabel 4.21. Analisis Stabilitas Dinding Penahan Hulu Kondisi Muka Air Normal (Gempa)**

Notasi	Nilai								Gaya		Lengan Momen		Momen	
	Lebar (m)	Tinggi (m)	Panjang (m)	Ratio			$\gamma$ (t/m <sup>3</sup> )	Pv (ton)	Ph (ton)	x (m)	y (m)	Mx (ton.m)	My (ton.m)	
	[1]	[2]	[3]	[4]			[5]	[6]	[7]	[8]	[9]	[10]	[11]	
Wc1	0,500	x 9,570	x 1,000	x 1,000			2,400	=	11,484	1,723	2,250	6,785	25,839	11,688
Wc2	1,500	x 9,570	x 1,000	x 0,500			2,400	=	17,226	2,584	3,000	5,190	51,678	13,410
Wc3	7,000	x 0,500	x 1,000	x 0,500			2,400	=	4,200	0,630	6,333	1,667	26,600	1,050
Wc4	2,000	x 0,500	x 1,000	x 1,000			2,400	=	2,400	0,360	3,000	1,750	7,200	0,630
Wc5	2,000	x 0,500	x 1,000	x 1,000			2,400	=	2,400	0,360	4,000	1,750	9,600	0,630
Wc6	11,000	x 1,500	x 1,000	x 1,000			2,400	=	39,600	5,940	5,500	0,750	217,800	4,455
Ws1	0,293	x 1,870	x 1,000	x 0,500			1,800	=	0,493				1,329	
Ws2	1,207	x 1,870	x 1,000	x 1,000			1,800	=	4,063				3,397	13,799
Ws3	7,000	x 1,870	x 1,000	x 1,000			1,800	=	23,562				7,500	176,715
Ws4	1,207	x 7,700	x 1,000	x 0,500			1,976	=	9,185				3,598	33,043
Ws5	7,000	x 7,700	x 1,000	x 1,000			1,976	=	106,532				7,500	798,988
Ws6	7,000	x 0,500	x 1,000	x 0,500			1,976	=	3,459				8,667	29,976
Pu1	11,000	x 5,951	x 1,000				1,000	=	-65,463			5,500		-360,045
	11,000	x 2,660	x 1,000	x 0,500			1,000	=	-14,633			7,333		-107,305
Pae1	Kae	x 0,500	x h <sub>1</sub>	x h <sub>1</sub>	x $\gamma$			=						
	0,408	x 0,500	x 1,870	x 1,870	x 1,800			=		1,283		10,323		13,246,0039
Pae2	Kae	x h <sub>1</sub>	x h <sub>2</sub>	x $\gamma$				=						
	0,408	x 1,870	x 9,700	x 1,800				=		13,311		4,850		64,560
Pae3	Kae	x 0,500	x h <sub>2</sub>	x h <sub>2</sub>	x $\gamma_{sub}$			=						
	0,408	x 0,500	x 9,700	x 9,700	x 0,976			=		18,729		3,233		60,557
Pw1	0,500	x h <sub>2</sub>	x h <sub>2</sub>				1,000	=						
	0,500	x 9,700	x 9,700				1,000	=		47,045		3,233		152,112
Ppe	Kpe	x 0,500	x h <sub>3</sub>	x h <sub>3</sub>	x $\gamma_{sub}$			=						
	1,536	x 0,500	x 4,000	x 4,000	x 0,976			=		-11,996		1,333		-15,995
Pw2	0,500	x h <sub>4</sub>	x h <sub>4</sub>				1,000	=						
	0,500	x 4,500	x 4,500				1,000	=		-10,125		1,500		-15,188
Pd1	7/12	x Kh	x h <sub>4</sub>	x h <sub>4</sub>				=						
	0,583	x 0,150	x 4,500	x 4,500			1,000	=		-1,772		1,500		-2,658
<b>TOTAL</b>							<b><math>\Sigma V</math></b>		<b>144,508</b>			<b><math>\Sigma Mv</math></b>	<b>925,217</b>	
							<b><math>\Sigma H</math></b>		<b>68,072</b>			<b><math>\Sigma Mh</math></b>	<b>288,498</b>	

Angka keamanan terhadap guling dan geser kondisi gempa :  
 SF Guling =  $\Sigma M v / \Sigma M h = 3,21 > 1,2$  Aman  
 SF Geser =  $(f \cdot \Sigma V) / \Sigma H = 1,49 > 1,2$  Aman

Kontrol terhadap eksentrisitas dan daya dukung izin tanah :  
 Eksentrisitas :  
 $L = 11,000$  m  
 $e = 1,094$  <  $L/6 = 1,83$  Aman

$f = 0,70$   
 $\phi = 27,5^\circ$

Tegangan maksimum dan minimum yang terjadi di bawah dasar pondasi :  
 Tegangan izin tanah = 18,26 ton/m<sup>2</sup>  
 Tegangan maks = 20,98 ton/m<sup>2</sup> > Tegangan izin tanah, Tidak aman  
 Tegangan min = 5,30 ton/m<sup>2</sup> < Tegangan izin tanah, Aman

Sumber: Hasil Perhitungan

**Keterangan:**

- [ 1 ] = lebar tiap bagian (m)
- [ 2 ] = tinggi tiap bagian (m)
- [ 3 ] = panjang konstruksi, tiap 1 meter panjang (m)
- [ 4 ] = 1 digunakan untuk penampang persegi atau persegi panjang  
 = 0,5 digunakan untuk penampang segitiga
- [ 5 ] = berat jenis beton bertulang = 2,4 (t/m<sup>3</sup>)  
 = berat jenis timbunan = 1,8 (t/m<sup>3</sup>)  
 = berat jenis tanah jenuh = 1,976 (t/m<sup>3</sup>)  
 = berat jenis air = 1,000 (t/m<sup>3</sup>)
- [ 6 ] = gaya vertikal (ton)  
 = [ 1 ] \* [ 2 ] \* [ 3 ] \* [ 4 ] \* [ 5 ]  
 (untuk bangunan, timbunan dan uplift)  
 nilai (+) untuk arah gaya ke bawah  
 nilai (-) untuk arah gaya ke atas
- [ 7 ] = gaya horizontal (ton)  
 = [ 6 ] \* kh, dengan kh = 0,15 (untuk berat bangunan)  
 = 7/12 \* [ 2 ]<sup>2</sup> \* [ 5 ] \* kh (untuk tekanan air dinamis)
- [ 8 ] = lengan momen gaya vertikal (m)
- [ 9 ] = lengan momen gaya horizontal (m)
- [ 10 ] = momen (ton.m)  
 = [ 6 ] \* [ 8 ]
- [ 11 ] = momen (ton.m)  
 = [ 7 ] \* [ 9 ]





**Tabel 4.22. Analisis Stabilitas Dinding Penahan Hulu Kondisi Muka Air Banjir (Tanpa Gempa)**

Notasi	Nilai							Gaya		Lengan Momen		Momen			
	Lebar (m)	Tinggi (m)	Panjang (m)	Ratio			$\gamma$ (t/m <sup>3</sup> )	Pv (ton)	Ph (ton)	x (m)	y (m)	Mx (ton.m)	My (ton.m)		
	[1]	[2]	[3]	[4]			[5]	[6]	[7]	[8]	[9]	[10]	[11]		
Wc1	0,500	x	9,570	x	1,000	x	1,000	2,400	=	11,484		2,250	25,839		
Wc2	1,500	x	9,570	x	1,000	x	0,500	2,400	=	17,226		3,000	51,678		
Wc3	7,000	x	0,500	x	1,000	x	0,500	2,400	=	4,200		6,333	26,600		
Wc4	2,000	x	0,500	x	1,000	x	1,000	2,400	=	2,400		3,000	7,200		
Wc5	2,000	x	0,500	x	1,000	x	1,000	2,400	=	2,400		1,000	2,400		
Wc6	11,000	x	1,500	x	1,000	x	1,000	2,400	=	39,600		5,500	217,800		
Ws1	0,235	x	1,500	x	1,000	x	0,500	1,800	=	0,317		2,657	0,843		
Ws2	1,265	x	1,500	x	1,000	x	1,000	1,800	=	3,416		3,368	11,502		
Ws3	7,000	x	1,500	x	1,000	x	1,000	1,800	=	18,900		7,500	141,750		
Ws4	1,265	x	8,070	x	1,000	x	0,500	1,976	=	10,088		3,578	36,100		
Ws5	7,000	x	8,070	x	1,000	x	1,000	1,976	=	111,651		7,500	837,381		
Ws6	7,000	x	0,500	x	1,000	x	0,500	1,976	=	3,459		8,667	29,976		
q	8,500	x	1,000						=	8,500		6,750	57,375		
Pu1	11,000	x	6,054	x	1,000			1,000	=	-66,599		5,500	-366,292		
	11,000	x	2,850	x	1,000	x	0,500	1,000	=	-15,674		7,333	-114,941		
Pa1	Ka	x	q	x	h <sub>1</sub>				=						
	0,398	x	1,000	x	1,500				=		0,597	10,820	6,459		
Pa2	Ka	x	0,5	x	h <sub>1</sub>	x	h <sub>1</sub>	x	$\gamma$						
	0,398	x	0,500	x	1,500	x	1,500	x	1,800			0,806	10,570	8,519	
Pa3	(Ka	x	q	+ Ka	x	$\gamma$	x	h <sub>1</sub> )	x	h <sub>2</sub>					
	(0,398	x	1,000	+ 0,398	x	1,800	x	1,870)	x	10,070			14,829	5,035	74,662
Pa4	Ka	x	0,5	x	h <sub>2</sub>	x	h <sub>2</sub>	x	$\gamma$ sub						
	0,398	x	0,500	x	10,070	x	10,070	x	0,976				19,704	3,357	66,140
Pw1	0,500	x	h <sub>2</sub>	x	h <sub>2</sub>				1,000	=					
	0,500	x	10,070	x	10,070				1,000	=			50,702	3,357	170,191
Pp	Kp	x	0,500	x	h <sub>3</sub>	x	h <sub>3</sub>	x	$\gamma$ sub						
	2,574	x	0,500	x	4,000	x	4,000	x	0,976				-20,110	1,333	-26,814
Pw2	0,500	x	h <sub>4</sub>	x	h <sub>4</sub>				1,000	=					
	0,500	x	4,500	x	4,500				1,000	=			-10,125	1,500	-15,188
<b>TOTAL</b>								<b><math>\Sigma V</math></b>		<b>151,369</b>		<b><math>\Sigma Mv</math></b>	<b>965,211</b>		
								<b><math>\Sigma H</math></b>		<b>56,402</b>		<b><math>\Sigma Mh</math></b>	<b>283,969</b>		
Angka keamanan terhadap guling dan geser kondisi tanpa gempa :															
SF Guling = $\Sigma M v / \Sigma M h =$											3,40		> 1,5 Aman		
SF Geser = $(f \cdot \Sigma V) / \Sigma H =$											1,88		> 1,5 Aman		
Kontrol terhadap eksentrisitas dan daya dukung izin tanah :															
Eksentrisitas :															
L = 11,000 m															
e = 0,999 <											L / 6 = 1,83		Aman		
f = 0,70															
Tegangan maksimum dan minimum yang terjadi di bawah dasar pondasi :															
$\phi = 27,5^\circ$															
Tegangan izin tanah = 18,26 ton/m <sup>2</sup>															
Tegangan maks = 21,26 ton/m <sup>2</sup>													> Tegangan izin tanah, Tidak aman		
Tegangan min = 6,26 ton/m <sup>2</sup>													< Tegangan izin tanah , Aman		

Sumber: Hasil Perhitungan

Keterangan:

- [ 1 ] = lebar tiap bagian (m)
- [ 2 ] = tinggi tiap bagian (m)
- [ 3 ] = panjang konstruksi, tiap 1 meter panjang (m)
- [ 4 ] = 1 digunakan untuk penampang persegi atau persegi panjang  
= 0,5 digunakan untuk penampang segitiga
- [ 5 ] = berat jenis beton bertulang = 2,4 (t/m<sup>3</sup>)  
= berat jenis tanah timbunan = 1,8 (t/m<sup>3</sup>)  
= berat jenis tanah jenuh = 1,976 (t/m<sup>3</sup>)  
= berat jenis air = 1,000 (t/m<sup>3</sup>)
- [ 6 ] = gaya vertikal (ton)  
= [ 1 ] \* [ 2 ] \* [ 3 ] \* [ 4 ] \* [ 5 ]  
(untuk bangunan, timbunan dan uplift)  
nilai (+) untuk arah gaya ke bawah  
nilai (-) untuk arah gaya ke atas
- [ 7 ] = gaya horizontal (ton)  
= [ 6 ] \* kh, dengan kh = 0,15 (untuk berat bangunan)  
=  $7/12 * [ 2 ]^2 * [ 5 ] * kh$  (untuk tekanan air dinamis)  
nilai (+) untuk arah gaya ke hilir  
nilai (-) untuk arah gaya ke hulu
- [ 8 ] = lengan momen gaya vertikal (m)
- [ 9 ] = lengan momen gaya horizontal (m)
- [ 10 ] = momen (ton.m)
- [ 11 ] = momen (ton.m)  
= [ 6 ] \* [ 8 ]  
= [ 7 ] \* [ 9 ]

**Tabel 4.23. Analisis Stabilitas Dinding Penahan Hulu Kondisi Muka Air Banjir (Gempa)**

Notasi	Nilai							$\gamma$ ( $t/m^3$ )	Gaya		Lengan Momen		Momen						
	Lebar (m)	Tinggi (m)	Panjang (m)	Ratio			Pv (ton)		Ph (ton)	x (m)	y (m)	Mx (ton.m)	My (ton.m)						
	[1]	[2]	[3]	[4]			[6]		[7]	[8]	[9]	[10]	[11]						
Wc1	0,500	x	9,570	x	1,000	x	1,000					2,400	=	11,484	1,723	2,250	6,785	25,839	11,688
Wc2	1,500	x	9,570	x	1,000	x	0,500					2,400	=	17,226	2,584	3,000	5,190	51,678	13,410
Wc3	7,000	x	0,500	x	1,000	x	0,500					2,400	=	4,200	0,630	6,333	1,667	26,600	1,050
Wc4	2,000	x	0,500	x	1,000	x	1,000					2,400	=	2,400	0,360	3,000	1,750	7,200	0,630
Wc5	2,000	x	0,500	x	1,000	x	1,000					2,400	=	2,400	0,360	1,000	1,667	2,400	0,600
Wc6	11,000	x	1,500	x	1,000	x	1,000					2,400	=	39,600	5,940	5,500	0,750	217,800	4,455
Ws1	0,235	x	1,500	x	1,000	x	0,500					1,800	=	0,317					0,843
Ws2	1,265	x	1,500	x	1,000	x	1,000					1,800	=	3,416					11,502
Ws3	7,000	x	1,500	x	1,000	x	1,000					1,800	=	18,900					141,750
Ws4	1,265	x	8,070	x	1,000	x	0,500					1,976	=	10,088					36,100
Ws5	7,000	x	8,070	x	1,000	x	1,000					1,976	=	111,651					837,381
Ws6	7,000	x	0,500	x	1,000	x	0,500					1,976	=	3,459					29,976
Pu1	11,000	x	6,054	x	1,000							1,000	=	-66,599					-366,292
	11,000	x	2,850	x	1,000	x	0,500					1,000	=	-15,674					-114,941
Pae1	Kae	x	0,500	x	h <sub>1</sub>	x	h <sub>1</sub>	x	$\gamma$				=						
	0,408	x	0,500	x	1,500	x	1,500	x	1,800				=		0,826				10,570
Pae2	Kae	x	h <sub>1</sub>	x	h <sub>2</sub>	x	$\gamma$						=						
	0,408	x	1,500	x	10,070	x	1,800						=		11,085				5,035
Pae3	Kae	x	0,500	x	h <sub>2</sub>	x	h <sub>2</sub>	x	$\gamma_{sub}$				=						
	0,408	x	0,500	x	10,070	x	10,070	x	0,976				=		20,185				3,357
Pw1	0,500	x	h <sub>2</sub>	x	h <sub>2</sub>							1,000	=						
	0,500	x	10,070	x	10,070							1,000	=		50,702				3,357
Ppe	Kpe	x	0,500	x	h <sub>3</sub>	x	h <sub>3</sub>	x	$\gamma_{sub}$				=						
	1,536	x	0,500	x	4,000	x	4,000	x	0,976				=		-11,996				1,333
Pw2	0,500	x	h <sub>4</sub>	x	h <sub>4</sub>							1,000	=						
	0,500	x	4,500	x	4,500							1,000	=		-10,125				1,500
Pd1	(7/12	x	Kh	x	h <sub>4</sub>	x	h <sub>4</sub>						=						
	0,583	x	0,150	x	4,500	x	4,500						=		-1,772				1,500
<b>TOTAL</b>												$\Sigma V$	=	<b>142,869</b>					$\Sigma Mv$
												$\Sigma H$	=	<b>70,501</b>					$\Sigma Mh$
													=						<b>907,836</b>
													=						<b>300,477</b>

Angka keamanan terhadap guling dan geser kondisi gempa :  
 SF Guling =  $\Sigma M v / \Sigma M h = 3,02 > 1,2$  Aman  
 SF Geser =  $-(f \cdot \Sigma V) / \Sigma H = 1,52 > 1,2$  Aman

Kontrol terhadap eksentrisitas dan daya dukung izin tanah :  
 Eksentrisitas :  
 $L = 11,000$  m  
 $e = 1,249$  <  
 $L / 6 = 1,83$  Aman

$f = 0,75$   
 $\phi = 27,5^\circ$

Tegangan maksimum dan minimum yang terjadi di bawah dasar pondasi :  
 Tegangan izin tanah = 18,26 ton/m<sup>2</sup>  
 Tegangan maks = 21,84 ton/m<sup>2</sup> > Tegangan izin tanah, Tidak aman  
 Tegangan min = 4,14 ton/m<sup>2</sup> < Tegangan izin tanah , Aman

Sumber: Hasil Perhitungan

**Keterangan:**

- [ 1 ] = lebar tiap bagian (m)
- [ 2 ] = tinggi tiap bagian (m)
- [ 3 ] = panjang konstruksi, tiap 1 meter panjang (m)
- [ 4 ] = 1 digunakan untuk penampang persegi atau persegi panjang  
= 0,5 digunakan untuk penampang segitiga
- [ 5 ] = berat jenis beton bertulang = 2,4 ( $t/m^3$ )  
= berat jenis tanah timbunan = 1,8 ( $t/m^3$ )  
= berat jenis tanah jenuh = 1,976 ( $t/m^3$ )  
= berat jenis air = 1,000 ( $t/m^3$ )
- [ 6 ] = gaya vertikal (ton)  
= [ 1 ] \* [ 2 ] \* [ 3 ] \* [ 4 ] \* [ 5 ]  
(untuk bangunan, timbunan dan uplift)  
nilai (+) untuk arah gaya ke bawah  
nilai (-) untuk arah gaya ke atas
- [ 7 ] = gaya horizontal (ton)  
= [ 6 ] \* kh , dengan kh = 0,15 (untuk berat bangunan)  
= 7/12 \* [ 2 ]<sup>2</sup> \* [ 5 ] \* kh (untuk tekanan air dinamis)  
nilai (+) untuk arah gaya ke hilir  
nilai (-) untuk arah gaya ke hulu
- [ 8 ] = lengan momen gaya vertikal (m)
- [ 9 ] = lengan momen gaya horizontal (m)
- [ 10 ] = momen (ton.m)  
= [ 6 ] \* [ 8 ]
- [ 11 ] = momen (ton.m)  
= [ 7 ] \* [ 9 ]



**Tabel 4.24. Rekapitulasi Stabilitas Dinding Penahan Bagian Hulu**

No.	Tinjauan analisa stabilitas	Angka keamanan terhadap guling		Angka keamanan terhadap geser		Eksentrisitas	L/6	Kontrol Eksentrisitas	Tegangan maks	Tegangan min	Tegangan izin	Kontrol Daya dukung
		SF Guling		SF Geser								
<b>A</b>	<b>Tinjauan Kondisi Normal</b>	SF > 1,5		SF > 1,5				$e \leq L/6$				$< \sigma$ izin
1	Muka Air Normal	3,615	Aman	1,986	Aman	0,855	1,833	Aman	20,394	7,426	18,258	Tidak Aman
2	Muka Air Banjir	3,399	Aman	1,879	Aman	0,999	1,833	Aman	21,263	6,259	18,258	Tidak Aman
<b>B</b>	<b>Tinjauan Kondisi Gempa</b>	SF > 1,2		SF > 1,2				$e \leq L/6$				
1	Muka Air Normal	3,207	Aman	1,486	Aman	1,094	1,833	Aman	20,975	5,299	18,258	Tidak Aman
2	Muka Air Banjir	3,021	Aman	1,520	Aman	1,249	1,833	Aman	21,835	4,141	18,258	Tidak Aman

Sumber: Hasil Perhitungan

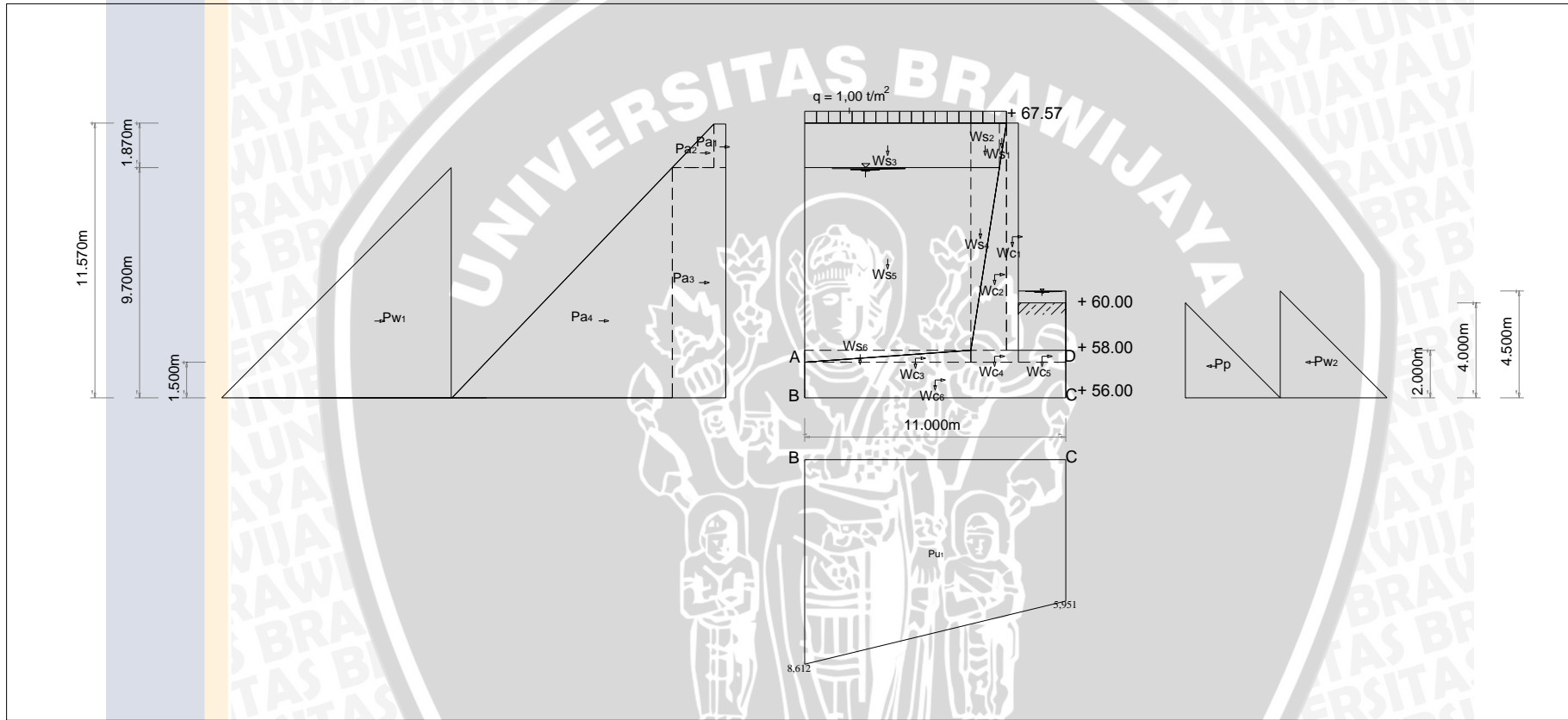

Gambar 4.18. Diagram Gaya Pada Dinding Penahan Hulu Kondisi Muka Air Normal (Tanpa Gempa)

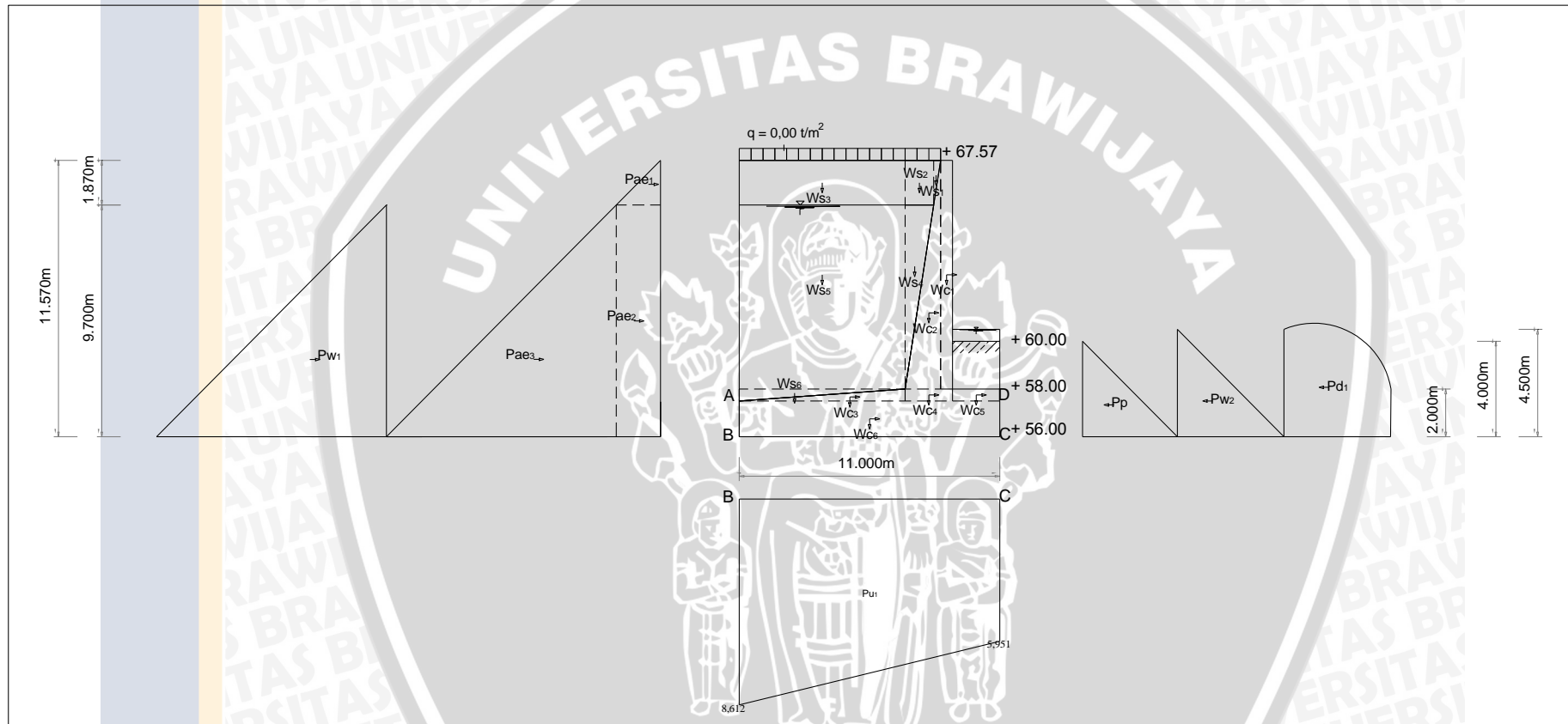

Gambar 4.19. Diagram Gaya Pada Dinding Penahan Hulu Kondisi Muka Air Normal (Gempa)

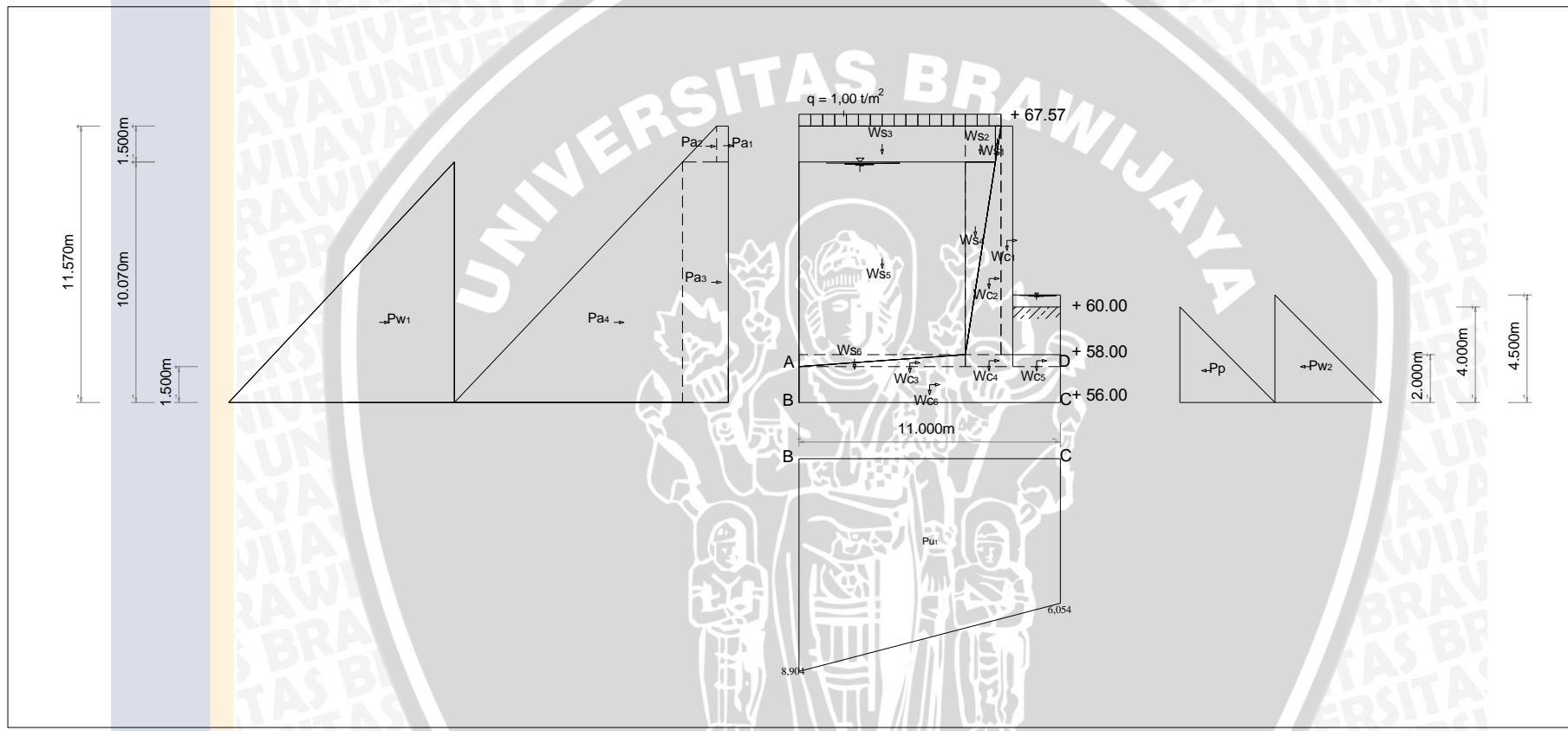

Gambar 4.20. Diagram Gaya Pada Dinding Penahan Hulu Kondisi Muka Air Banjir (Tanpa Gempa)

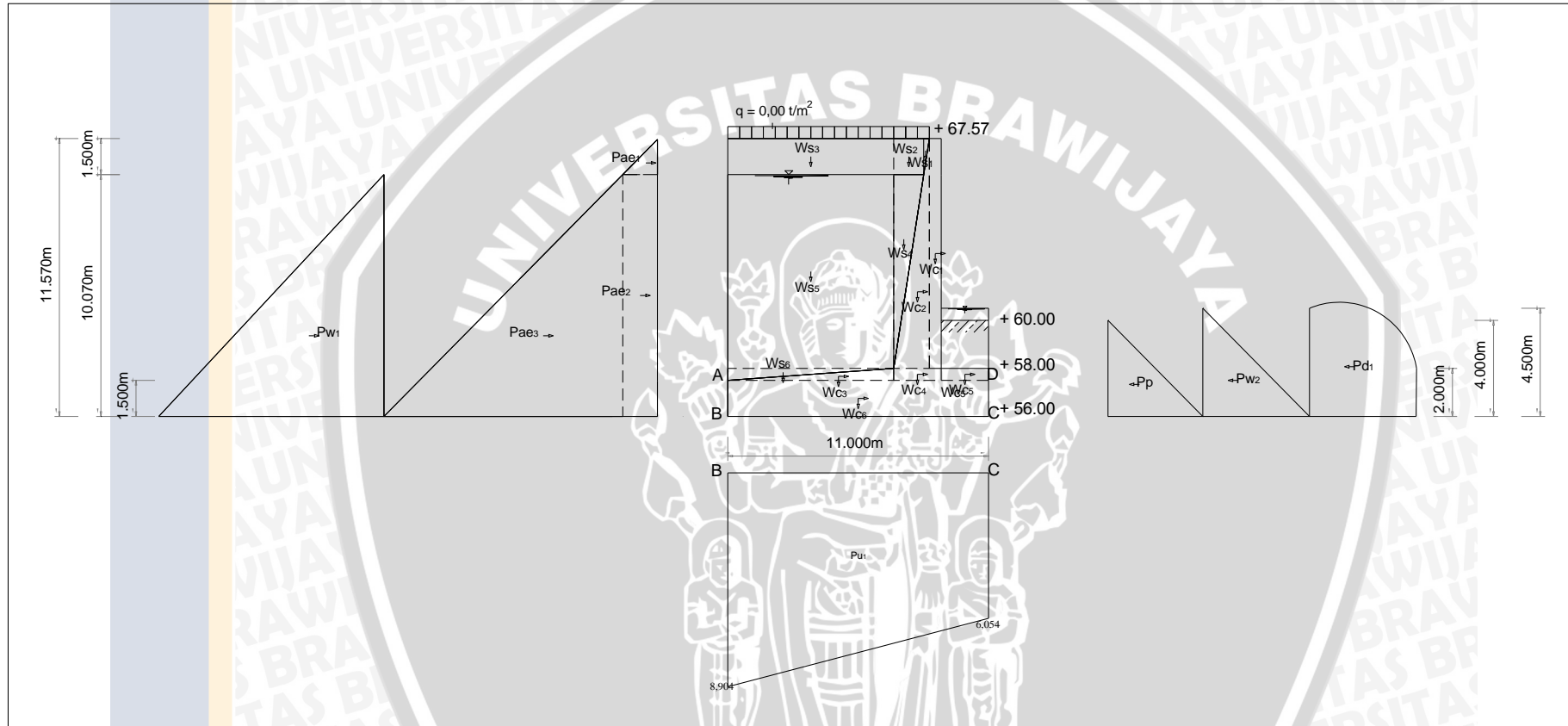

Gambar 4.21. Diagram Gaya Pada Dinding Penahan Hulu Kondisi Muka Air Banjir (Tanpa Gempa)

#### 4.3.4. Dinding Penahan Tanah Bagian Jembatan

Gaya berat dari dinding penahan disesuaikan dengan dimensi dari bangunan tersebut. Untuk mempermudah dalam perhitungan beban vertikal maka bangunan perlu dibagi menjadi bagian-bagian kecil yang disajikan secara visual seperti pada Gambar 4.22. dan Gambar 4.23. Perhitungan gaya berat pada dinding penahan tanah menggunakan persamaan (2-12) dapat dilihat pada Tabel 4.25.

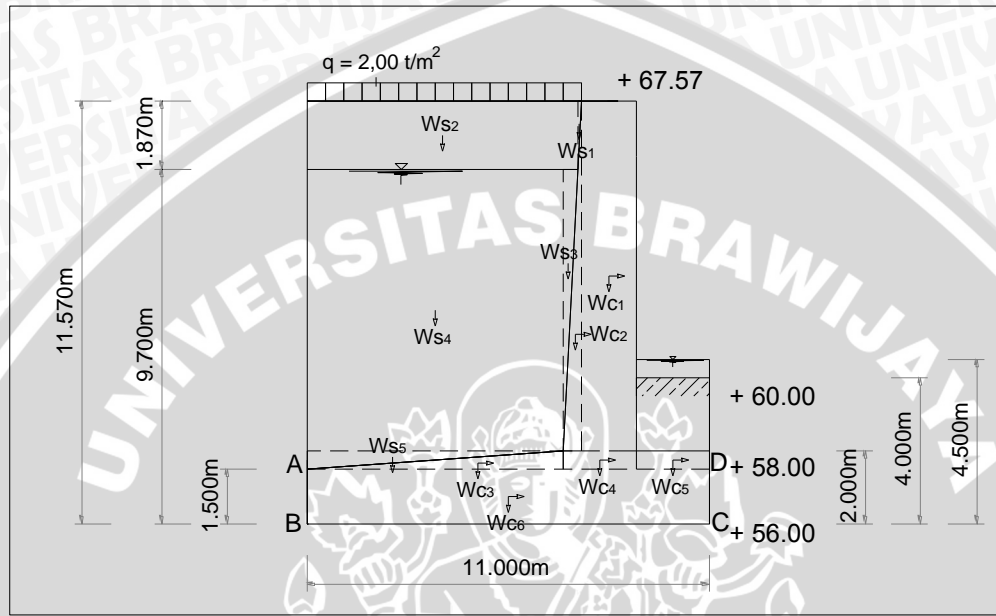

**Gambar 4.22. Gaya Berat pada Dinding Penahan Tanah Bagian Jembatan Kondisi Muka Air Normal**

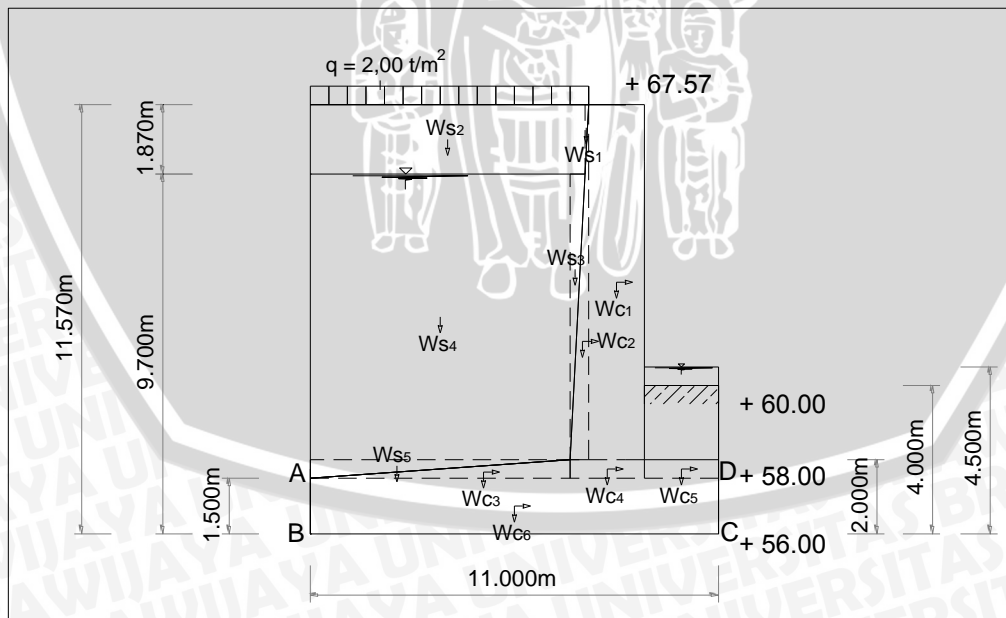

**Gambar 4.23. Gaya Berat pada Dinding Penahan Tanah Bagian Jembatan Kondisi Muka Air Banjir**



**Tabel 4.25. Perhitungan Gaya Berat pada Dinding Penahan Tanah Bagian Jembatan**

Notasi	Nilai				Volume m <sup>3</sup>	$\gamma$ (t/m <sup>3</sup> )	Gaya Berat (t)
	Lebar	Tinggi	Panjang	Ratio			
	[ 1 ]	[ 2 ]	[ 3 ]	[ 4 ]	[ 5 ]	[ 6 ]	[ 7 ]
Wc <sub>1</sub>	1,500	9,570	1,000	1,000	14,355	2,400	34,452
Wc <sub>2</sub>	0,500	9,570	1,000	0,500	2,393	2,400	5,742
Wc <sub>3</sub>	7,000	0,500	1,000	0,500	1,750	2,400	4,200
Wc <sub>4</sub>	2,000	0,500	1,000	1,000	1,000	2,400	2,400
Wc <sub>5</sub>	2,000	0,500	1,000	1,000	1,000	2,400	2,400
Wc <sub>6</sub>	11,000	1,500	1,000	1,000	16,500	2,400	39,600
Total							88,794

Sumber: Hasil Perhitungan

Keterangan:

[ 1 ] = lebar tiap bagian (m)

[ 2 ] = tinggi tiap bagian (m)

[ 3 ] = panjang konstruksi, tiap 1 meter panjang (m)

[ 4 ] = 1 digunakan untuk penampang persegi atau persegi panjang  
= 0,5 digunakan untuk penampang segitiga

[ 5 ] = volume (m<sup>3</sup>)  
= [ 1 ] \* [ 2 ] \* [ 3 ] \* [ 4 ]

[ 6 ] = berat jenis beton bertulang = 2,4 (t/m<sup>3</sup>)

[ 7 ] = gaya berat konstruksi (ton)  
= [ 5 ] \* [ 6 ]

Perhitungan *uplift* pada kondisi normal maupun pada kondisi banjir disajikan pada Tabel 4.26 dan 4.27. Perhitungan analisis stabilitas pada berbagai kondisi disajikan pada Tabel 4.28 sampai dengan Tabel 4.31. Diagram gaya yang bekerja pada dinding penahan tanah sesuai dengan kondisi yang dianalisis disajikan pada Gambar 4.24. sampai dengan Gambar 4.27. Rekapitulasi hasil perhitungan stabilitas dinding penahan bagian jembatan dengan berbagai kondisi yang telah dianalisis pada halaman sebelumnya, disajikan pada Tabel 4.32.

**Tabel 4.26. Perhitungan Gaya Uplift tiap titik pada Dinding Penahan Tanah Kondisi Muka Air Normal**

Panjang Creep = 7,167  
 Tinggi air di hulu = 9,700  
 Tinggi air di hilir = 4,500

Titik	Garis	Panjang Rembesan				$\Delta H$	Hx	Uplift
		Vertikal	Horizont al	1/3.Horiz ontal	Jarak			
		[ 1 ]	[ 2 ]	[ 3 ]	[ 4 ]			
A					0,000	0,000	8,200	8,200
	A-B	1,500						
B					1,500	1,088	9,700	8,612
	B-C		11,000	3,667				
C					5,167	3,749	9,700	5,951
	C-D	2,000						
D					7,167	5,200	7,700	2,500

Sumber: Hasil Perhitungan

$$\begin{aligned}
 C_w (\text{Lane}) &= \frac{L_w}{H_w} \\
 &= \frac{7,167}{5,200} \\
 &= 1,378
 \end{aligned}$$

Keterangan:

Keterangan:

- [ 1 ] = panjang rembesan vertikal tiap garis (m)  
 [ 2 ] = panjang rembesan horizontal tiap garis (m)  
 [ 3 ] = [ 2 ] \* 1/3  
 [ 4 ] = jarak kumulatif di tiap titik (m)  
 = [ 1 ]<sub>n</sub> + [ 3 ]<sub>n-1</sub>  
 [ 5 ] = pengurangan tekanan air (t/m)  
 =  $L_w/C_w$   
 [ 6 ] = jarak muka air ke titik x (t/m)  
 [ 7 ] = gaya uplift (t/m)  
 = [ 6 ] - [ 5 ]  
 Hw = Tinggi Energi hulu - tinggi energi di hilir  
 = 5,200

**Tabel 4.27. Perhitungan Gaya Uplift tiap titik pada Dinding Penahan Tanah Kondisi Muka Air Banjir**

Panjang Creep = 7,167  
 Tinggi air di hulu = 10,070  
 Tinggi air di hilir = 4,500

Titik	Garis	Panjang Rembesan				$\Delta H$	Hx	Uplift
		Vertikal	Horizont al	1/3.Horiz ontal	Jarak			
		[ 1 ]	[ 2 ]	[ 3 ]	[ 4 ]			
A					0,000	0,000	8,570	8,570
B	A-B	1,500						
	B-C		11,000	3,667				
C					5,167	4,016	10,070	6,054
	C-D	2,000						
D					7,167	5,570	8,070	2,500

Sumber: Hasil Perhitungan

$$\begin{aligned}
 Cw (\text{Lane}) &= \frac{Lw}{Hw} \\
 &= \frac{7,167}{5,570} \\
 &= 1,287
 \end{aligned}$$

Keterangan:

Keterangan:

- [ 1 ] = panjang rembesan vertikal tiap garis (m)  
 [ 2 ] = panjang rembesan horizontal tiap garis (m)  
 [ 3 ] = [ 2 ] \* 1/3  
 [ 4 ] = jarak kumulatif di tiap titik (m)  
 = [ 1 ]<sub>n</sub> + [ 3 ]<sub>n-1</sub>  
 [ 5 ] = pengurangan tekanan air (t/m)  
 = Lw/Cw  
 [ 6 ] = jarak muka air ke titik x (t/m)  
 [ 7 ] = gaya uplift (t/m)  
 = [ 6 ] - [ 5 ]  
 Hw = Tinggi Energi hulu - tinggi energi di hilir  
 = 5,570

**Tabel 4.28. Analisis Stabilitas Dinding Penahan Tanah Jembatan Kondisi Muka Air Normal (Tanpa Gempa)**

Notasi	Nilai								Gaya		Lengan Momen		Momen		
	Lebar (m)	Tinggi (m)	Panjang (m)	Ratio				$\gamma$ ( $t/m^3$ )	Pv (ton)	Ph (ton)	x (m)	y (m)	Mx (ton.m)	My (ton.m)	
	[1]	[2]	[3]	[4]				[5]	[6]	[7]	[8]	[9]	[10]	[11]	
Wc1	1,500	x	9,570	x	1,000	x	1,000		2,400	=	34,452		2,750		94,743
Wc2	0,500	x	9,570	x	1,000	x	0,500		2,400	=	5,742		3,667		21,054
Wc3	7,000	x	0,500	x	1,000	x	0,500		2,400	=	4,200		6,333		26,600
Wc4	2,000	x	0,500	x	1,000	x	1,000		2,400	=	2,400		3,000		7,200
Wc5	2,000	x	0,500	x	1,000	x	1,000		2,400	=	2,400		1,000		2,400
Wc6	11,000	x	1,500	x	1,000	x	1,000		2,400	=	39,600		5,500		217,800
Ws1	0,098	x	1,870	x	1,000	x	0,500		1,800	=	0,165		3,565		0,588
Ws2	7,402	x	1,870	x	1,000	x	1,000		1,800	=	24,915		7,299		181,856
Ws3	0,402	x	7,700	x	1,000	x	0,500		1,976	=	3,059		3,866		11,826
Ws4	7,000	x	7,700	x	1,000	x	1,000		1,976	=	106,532		7,500		798,988
Ws5	7,000	x	0,500	x	1,000	x	0,500		1,976	=	3,459		8,667		29,976
q	7,500	x	2,000							=	15,000		7,250		108,750
Pu1	11,000	x	5,951	x	1,000				1,000	=	-65,463		5,500		-360,045
	11,000	x	2,660	x	1,000	x	0,500		1,000	=	-14,633		7,333		-107,305
Pa1	Ka	x	q	x	h1					=					
	0,354	x	2,000	x	1,870					=			1,324		10,635
Pa2	Ka	x	0,5	x	h1	x	h1	x	$\gamma$						
	0,354	x	0,500	x	1,870	x	1,870	x	1,800					1,114	10,323
Pa3	(Ka	x	q	+	Ka	x	$\gamma$	x	h1)	x	h2				
	(0,354	x	2,000	+	0,354	x	1,800	x	1,870)	x	9,700				18,421
Pa4	Ka	x	0,5	x	h2	x	h2	x	$\gamma_{sub}$					4,850	89,342
	0,354	x	0,500	x	9,700	x	9,700	x	0,976					16,258	3,233
Pw1	0,500	x	h2	x	h2				1,000	=					
	0,500	x	9,700	x	9,700				1,000	=				47,045	3,233
Pp	Kp	x	0,500	x	h3	x	h3	x	$\gamma_{sub}$						
	2,833	x	0,500	x	4,000	x	4,000	x	0,976						-22,133
Pw2	0,500	x	h4	x	h4				1,000	=					
	0,500	x	4,500	x	4,500				1,000	=				-10,125	1,500
<b>TOTAL</b>									<b><math>\Sigma V</math></b>		<b>161,828</b>		<b><math>\Sigma Mv</math></b>		<b>1034,431</b>
									<b><math>\Sigma H</math></b>		<b>51,903</b>		<b><math>\Sigma Mh</math></b>		<b>274,898</b>

Angka keamanan terhadap guling dan geser kondisi tanpa gempa :  
 SF Guling =  $\Sigma M v / \Sigma M h = 3,76 > 1,5$  Aman  
 SF Geser =  $(f \cdot \Sigma V) / \Sigma H = 2,18 > 1,5$  Aman

Kontrol terhadap eksentrisitas dan daya dukung izin tanah :  
 Eksentrisitas :  
 $L = 11,000$  m  
 $e = 0,807$  <  $L / 6 = 1,83$  Aman

f = 0,70  
 $\phi = 27,5^\circ$

Tegangan maksimum dan minimum yang terjadi di bawah dasar pondasi :  
 Tegangan izin tanah = 18,26  $ton/m^2$   
 Tegangan maks = 21,18  $ton/m^2$  > Tegangan izin tanah, Tidak aman  
 Tegangan min = 8,24  $ton/m^2$  < Tegangan izin tanah, Aman

Sumber: Hasil Perhitungan

Keterangan:

- [ 1 ] = lebar tiap bagian (m)
- [ 2 ] = tinggi tiap bagian (m)
- [ 3 ] = panjang konstruksi, tiap 1 meter panjang (m)
- [ 4 ] = 1 digunakan untuk penampang persegi atau persegi panjang  
= 0,5 digunakan untuk penampang segitiga
- [ 5 ] = berat jenis beton bertulang = 2,4 ( $t/m^3$ )  
= berat jenis timbunan = 1,8 ( $t/m^3$ )  
= berat jenis tanah jenuh = 1,976 ( $t/m^3$ )  
= berat jenis air = 1,000 ( $t/m^3$ )
- [ 6 ] = gaya vertikal (ton)  
= [ 1 ] \* [ 2 ] \* [ 3 ] \* [ 4 ] \* [ 5 ]  
(untuk bangunan, timbunan dan uplift)  
nilai (+) untuk arah gaya ke bawah  
nilai (-) untuk arah gaya ke atas
- [ 7 ] = gaya horizontal (ton)  
= [ 6 ] \* kh, dengan kh = 0,15 (untuk berat bangunan)  
=  $7/12 * [ 2 ]^2 * [ 5 ] * kh$  (untuk tekanan air dinamis)  
nilai (+) untuk arah gaya ke hilir  
nilai (-) untuk arah gaya ke hulu
- [ 8 ] = lengan momen gaya vertikal (m)
- [ 9 ] = lengan momen gaya horizontal (m)
- [ 10 ] = momen (ton.m)  
= [ 6 ] \* [ 8 ]
- [ 11 ] = momen (ton.m)  
= [ 7 ] \* [ 9 ]



**Tabel 4.29. Analisis Stabilitas Dinding Penahan Tanah Jembatan Kondisi Muka Air Normal (Gempa)**

Notasi	Nilai							$\gamma$ (t/m <sup>3</sup> )	Gaya		Lengan Momen		Momen			
	Lebar (m)	Tinggi (m)	Panjang (m)	Ratio			Pv (ton)		Ph (ton)	x (m)	y (m)	Mx (ton.m)	My (ton.m)			
	[1]	[2]	[3]	[4]			[6]		[7]	[8]	[9]	[10]	[11]			
Wc1	1,500	x	9,570	x	1,000	x	1,000		2,400	=	34,452	5,168	2,750	6,785	94,743	35,064
Wc2	0,500	x	9,570	x	1,000	x	0,500		2,400	=	5,742	0,861	3,667	5,190	21,054	4,470
Wc3	7,000	x	0,500	x	1,000	x	0,500		2,400	=	4,200	0,630	6,333	1,667	26,600	1,050
Wc4	2,000	x	0,500	x	1,000	x	1,000		2,400	=	2,400	0,360	3,000	1,750	7,200	0,630
Wc5	2,000	x	0,500	x	1,000	x	1,000		2,400	=	2,400	0,360	1,000	1,750	2,400	0,630
Wc6	11,000	x	1,500	x	1,000	x	1,000		2,400	=	39,600	5,940	5,500	0,750	217,800	4,455
Ws1	0,098	x	1,870	x	1,000	x	0,500		1,800	=	0,165		3,565			0,588
Ws2	7,402	x	1,870	x	1,000	x	1,000		1,800	=	24,915		7,299			181,856
Ws3	0,402	x	7,700	x	1,000	x	0,500		1,976	=	3,059		3,866			11,826
Ws4	7,000	x	7,700	x	1,000	x	1,000		1,976	=	106,532		7,500			798,988
Ws5	7,000	x	0,500	x	1,000	x	0,500		1,976	=	3,459		8,667			29,976
Pu1	11,000	x	5,951	x	1,000				1,000	=	-65,463		5,500			-360,045
	11,000	x	2,660	x	1,000	x	0,500		1,000	=	-14,633		7,333			-107,305
Pae1	Kae	x	0,500	x	h <sub>1</sub>	x	h <sub>1</sub>	x	$\gamma$	=						
	0,408	x	0,500	x	1,870	x	1,870	x	1,800	=		1,283		10,323		13,246
Pae2	Kae	x	h <sub>1</sub>	x	h <sub>2</sub>	x	$\gamma$			=						
	0,408	x	1,870	x	9,700	x	1,800			=		13,311		4,850		64,5605
Pae3	Kae	x	0,500	x	h <sub>2</sub>	x	h <sub>2</sub>	x	$\gamma_{sub}$	=						
	0,408	x	0,500	x	9,700	x	9,700	x	0,976	=		18,729		3,233		60,5567
Pw1	0,500	x	h <sub>2</sub>	x	h <sub>2</sub>				1,000	=						
	0,500	x	9,700	x	9,700				1,000	=		47,045		3,233		152,112
Ppe	Kpe	x	0,500	x	h <sub>3</sub>	x	h <sub>3</sub>	x	$\gamma_{sub}$	=						
	1,536	x	0,500	x	4,000	x	4,000	x	0,976	=		-11,996		1,333		-15,9952
Pw2	0,500	x	h <sub>4</sub>	x	h <sub>4</sub>				1,000	=						
	0,500	x	4,500	x	4,500				1,000	=		-10,125		1,500		-15,1875
Pd1	(7/12	x	Kh	x	h <sub>4</sub>	x	h <sub>4</sub>			=						
	0,583	x	0,150	x	4,500	x	4,500		1,000	=		-1,772		1,500		-2,65781
<b>TOTAL</b>									<b><math>\Sigma V</math></b>		<b>146,828</b>		<b><math>\Sigma Mv</math></b>		<b>925,681</b>	
									<b><math>\Sigma H</math></b>		<b>69,794</b>		<b><math>\Sigma Mh</math></b>		<b>302,934</b>	

Angka keamanan terhadap guling dan geser kondisi gempa :  
 SF Guling =  $\frac{\Sigma Mv}{\Sigma Mh} = \frac{3,06}{1,47} > 1,2$  Aman  
 SF Geser =  $\frac{\Sigma V}{\Sigma H} = \frac{146,828}{69,794} > 1,2$  Aman  
 Kontrol terhadap eksentrisitas dan daya dukung izin tanah :  
 Eksentrisitas :  
 $L = 11,000$  m  
 $e = 1,259$  <  $L/6 = 1,833$  Aman  
 $f = 0,70$   
 $\phi = 27,5^\circ$   
 Tegangan maksimum dan minimum yang terjadi di bawah dasar pondasi :  
 Tegangan izin tanah = 18,26 ton/m<sup>2</sup>  
 Tegangan maks = 22,51 ton/m<sup>2</sup> > Tegangan izin tanah, Tidak aman  
 Tegangan min = 4,18 ton/m<sup>2</sup> < Tegangan izin tanah, Aman

Sumber: Hasil Perhitungan

Keterangan:

- [ 1 ] = lebar tiap bagian (m)
- [ 2 ] = tinggi tiap bagian (m)
- [ 3 ] = panjang konstruksi, tiap 1 meter panjang (m)
- [ 4 ] = 1 digunakan untuk penampang persegi atau persegi panjang  
= 0,5 digunakan untuk penampang segitiga
- [ 5 ] = berat jenis beton bertulang = 2,4 (t/m<sup>3</sup>)  
= berat jenis tanah timbunan = 1,8 (t/m<sup>3</sup>)  
= berat jenis tanah jenuh = 1,976 (t/m<sup>3</sup>)  
= berat jenis air = 1,000 (t/m<sup>3</sup>)
- [ 6 ] = gaya vertikal (ton)  
= [ 1 ] \* [ 2 ] \* [ 3 ] \* [ 4 ] \* [ 5 ]  
(untuk bangunan, timbunan dan uplift)  
nilai (+) untuk arah gaya ke bawah  
nilai (-) untuk arah gaya ke atas
- [ 7 ] = gaya horizontal (ton)  
= [ 6 ] \* kh, dengan kh = 0,15 (untuk berat bangunan)  
= 7/12 \* [ 2 ]<sup>2</sup> \* [ 5 ] \* kh (untuk tekanan air dinamis)  
nilai (+) untuk arah gaya ke hilir  
nilai (-) untuk arah gaya ke hulu
- [ 8 ] = lengan momen gaya vertikal (m)
- [ 9 ] = lengan momen gaya horizontal (m)
- [ 10 ] = momen (ton.m)  
= [ 6 ] \* [ 8 ]
- [ 11 ] = momen (ton.m)  
= [ 7 ] \* [ 9 ]



**Tabel 4.30. Analisis Stabilitas Dinding Penahan Tanah Jembatan Kondisi Muka Air Banjir (Tanpa Gempa)**

Notasi	Nilai								Gaya		Lengan Momen		Momen	
	Lebar (m)	Tinggi (m)	Panjang (m)		Ratio		$\gamma$ (t/m <sup>3</sup> )	Pv (ton)	Ph (ton)	x (m)	y (m)	Mx (ton.m)	My (ton.m)	
	[1]	[2]	[3]	[4]	[5]	[6]	[7]	[8]	[9]	[10]	[11]			
Wc1	1,500	x	9,570	x	1,000	x	1,000		2,400	=	34,452	2,750		94,743
Wc2	0,500	x	9,570	x	1,000	x	0,500		2,400	=	5,742	3,667		21,054
Wc3	7,000	x	0,500	x	1,000	x	0,500		2,400	=	4,200	6,333		26,600
Wc4	2,000	x	0,500	x	1,000	x	1,000		2,400	=	2,400	3,000		7,200
Wc5	2,000	x	0,500	x	1,000	x	1,000		2,400	=	2,400	1,000		2,400
Wc6	11,000	x	1,500	x	1,000	x	1,000		2,400	=	39,600	5,500		217,800
Wsi	0,078	x	1,500	x	1,000	x	0,500		1,800	=	0,105	3,552		0,374
Ws2	7,422	x	1,500	x	1,000	x	1,000		1,800	=	20,039	7,289		146,067
Ws3	0,422	x	8,070	x	1,000	x	0,500		1,800	=	3,065	3,859		11,829
Ws4	7,000	x	8,070	x	1,000	x	1,000		1,976	=	111,651	7,500		837,381
Ws5	7,000	x	0,500	x	1,000	x	0,500		1,976	=	3,459	8,667		29,976
q	7,500	x	2,000							=	15,000	7,250		108,750
Pu1	11,000	x	6,054	x	1,000				1,000	=	-66,599	5,500		-366,292
	11,000	x	2,850	x	1,000	x	0,500		1,000	=	-15,674	7,333		-114,941
Pa1	Ka	x	q	x	h <sub>1</sub>									
	0,354	x	2,000	x	1,500					=	1,062	10,820		11,488
Pa2	Ka	x	0,5	x	h <sub>1</sub>	x	h <sub>1</sub>	x	y					
	0,354	x	0,500	x	1,500	x	1,500	x	1,800	=	0,717	10,570		7,575
Pa3	(Ka	x	q	+ Ka	x	y	x	h <sub>1</sub>	x	h <sub>2</sub>				
	(0,354	x	2,000	+ 0,354	x	1,800	x	1,500)	x	10,070	=	16,750	5,035	84,337
Pa4	Ka	x	0,5	x	h <sub>2</sub>	x	h <sub>2</sub>	x	ysub					
	0,354	x	0,500	x	10,070	x	10,070	x	0,976	=	17,522	3,357		58,815
Pw1	0,500	x	h <sub>2</sub>	x	h <sub>2</sub>					1,000	=			
	0,500	x	10,070	x	10,070					1,000	=	50,702	3,357	170,191
Pp	Kp	x	0,500	x	h <sub>3</sub>	x	h <sub>3</sub>	x	ysub					
	2,833	x	0,500	x	4,000	x	4,000	x	0,976	=	-22,133	1,333		-29,511
Pw2	0,500	x	h <sub>4</sub>	x	h <sub>4</sub>					1,000	=			
	0,500	x	4,500	x	4,500					1,000	=	-10,125	1,500	-15,188
<b>TOTAL</b>									<b>Σ V</b>	<b>159,841</b>		<b>Σ Mv</b>	<b>1022,942</b>	
									<b>Σ H</b>	<b>54,495</b>		<b>Σ Mh</b>	<b>287,708</b>	
Angka keamanan terhadap guling dan geser kondisi tanpa gempa : SF Guling = $\Sigma M v / \Sigma M h =$ 3,56 > 1,5 Aman SF Geser = $=(f \cdot \Sigma V) / \Sigma H =$ 2,05 > 1,5 Aman Kontrol terhadap eksentrisitas dan daya dukung izin tanah : Eksentrisitas : $L = 11,000$ m $e = 0,900$ < $L / 6 = 1,83$ Aman Tegangan maksimum dan minimum yang terjadi di bawah dasar pondasi : Tegangan izin tanah = 18,26 ton/m <sup>2</sup> Tegangan maks = 21,67 ton/m <sup>2</sup> > Tegangan izin tanah, Tidak aman Tegangan min = 7,40 ton/m <sup>2</sup> < Tegangan izin tanah , Aman														

Sumber: Hasil Perhitungan

**Keterangan:**

- [ 1 ] = lebar tiap bagian (m)
- [ 2 ] = tinggi tiap bagian (m)
- [ 3 ] = panjang konstruksi, tiap 1 meter panjang
- [ 4 ] = 1 digunakan untuk penampang persegi atau persegi panjang  
= 0,5 digunakan untuk penampang segitiga
- [ 5 ] = berat jenis beton bertulang = 2,4 (t/m<sup>3</sup>)  
= berat jenis tanah timbunan = 1,8 (t/m<sup>3</sup>)  
= berat jenis tanah jenuh = 1,976 (t/m<sup>3</sup>)  
= berat jenis air = 1,000 (t/m<sup>3</sup>)
- [ 6 ] = gaya vertikal (ton)  
= [ 1 ] \* [ 2 ] \* [ 3 ] \* [ 4 ] \* [ 5 ]  
(untuk bangunan, timbunan dan uplift)  
nilai (+) untuk arah gaya ke bawah  
nilai (-) untuk arah gaya ke atas
- [ 7 ] = gaya horizontal (ton)  
= [ 6 ] \* kh , dengan kh = 0,15 (untuk berat bangunan)  
= 7/12 \* [ 2 ]<sup>2</sup> \* [ 5 ] \* kh (untuk tekanan air dinamis)  
nilai (+) untuk arah gaya ke hilir  
nilai (-) untuk arah gaya ke hulu
- [ 8 ] = lengan momen gaya vertikal (m)
- [ 9 ] = lengan momen gaya horizontal (m)
- [ 10 ] = momen (ton.m)  
= [ 6 ] \* [ 8 ]
- [ 11 ] = momen (ton.m)  
= [ 7 ] \* [ 9 ]



**Tabel 4.31. Analisis Stabilitas Dinding Penahan Tanah Jembatan Kondisi Muka Air Banjir (Gempa)**

Notasi	Nilai						$\gamma$ ( $t/m^3$ )	Gaya		Lengan Momen		Momen	
	Lebar (m)	Tinggi (m)	Panjang (m)	Ratio				Pv (ton)	Ph (ton)	x (m)	y (m)	Mx (ton.m)	My (ton.m)
	[1]	[2]	[3]	[4]				[5]	[6]	[7]	[8]	[9]	[10]
Wc1	1,500	x 9,570	x 1,000	x 1,000			2,400	= 34,452	5,168	2,750	6,785	94,743	35,064
Wc2	0,500	x 9,570	x 1,000	x 0,500			2,400	= 5,742	0,861	3,667	5,190	21,054	4,470
Wc3	7,000	x 0,500	x 1,000	x 0,500			2,400	= 4,200	0,630	6,333	1,667	26,600	1,050
Wc4	2,000	x 0,500	x 1,000	x 1,000			2,400	= 2,400	0,360	3,000	1,750	7,200	0,630
Wc5	2,000	x 0,500	x 1,000	x 1,000			2,400	= 2,400	0,360	1,000	1,750	2,400	0,630
Wc6	11,000	x 1,500	x 1,000	x 1,000			2,400	= 39,600	5,940	5,500	0,750	217,800	4,455
Wsi	0,078	x 1,500	x 1,000	x 0,500			1,800	= 0,105			3,552		0,374
Ws2	7,422	x 1,500	x 1,000	x 1,000			1,800	= 20,039			7,289		146,067
Ws3	0,422	x 8,070	x 1,000	x 0,500			1,800	= 3,065			3,859		11,829
Ws4	7,000	x 8,070	x 1,000	x 1,000			1,976	= 111,651			7,500		837,381
Wss	7,000	x 0,500	x 1,000	x 0,500			1,976	= 3,459			8,667		29,976
Pu1	11,000	x 6,054	x 1,000				1,000	= -66,599			5,500		-366,292
	11,000	x 2,850	x 1,000	x 0,500			1,000	= -15,674			7,333		-114,941
Paei	Kae	x 0,500	x h <sub>1</sub>	x h <sub>1</sub>	x y			=					
	0,408	x 0,500	x 1,500	x 1,500	x 1,800			=			0,826		10,570
Pae2	Kae	x h <sub>1</sub>	x h <sub>2</sub>	x y				=					
	0,408	x 1,500	x 10,070	x 1,800				=			11,085		55,8126
Paes	Kae	x 0,500	x h <sub>2</sub>	x h <sub>2</sub>	x ysub			=					
	0,408	x 0,500	x 10,070	x 10,070	x 0,976			=			20,185		3,357
Pw1	0,500	x h <sub>2</sub>	x h <sub>2</sub>				1,000	=					
	0,500	x 10,070	x 10,070				1,000	=			50,702		3,357
Ppe	Kpe	x 0,500	x h <sub>3</sub>	x h <sub>3</sub>	x ysub			=					
	1,536	x 0,500	x 4,000	x 4,000	x 0,976			=			-11,996		1,333
Pw2	0,500	x h <sub>4</sub>	x h <sub>4</sub>				1,000	=					
	0,500	x 4,500	x 4,500				1,000	=			-10,125		1,500
Pdi	(7/12	x Kh	x h <sub>4</sub>	x h <sub>4</sub>				=					
	0,583	x 0,150	x 4,500	x 4,500			1,000	=			-1,772		1,500
<b>TOTAL</b>							<b>Σ V</b>	<b>144,841</b>			<b>Σ Mv</b>	<b>914,192</b>	
							<b>Σ H</b>		<b>72,224</b>		<b>Σ Mh</b>		<b>314,943</b>

Angka keamanan terhadap guling dan geser kondisi gempa :  
 SF Guling =  $\Sigma M v / \Sigma M h = 2,90 > 1,2$  Aman  
 SF Geser =  $-(f \cdot \Sigma V) / \Sigma H = 1,40 > 1,2$  Aman

Kontrol terhadap eksentrisitas dan daya dukung izin tanah :  
 Eksentrisitas :  
 $L = 11,000$  m  
 $e = 1,363$  <  $L/6 = 1,83$  Aman

f = 0,70  
 $\phi = 27,5^\circ$

Tegangan maksimum dan minimum yang terjadi di bawah dasar pondasi :  
 Tegangan izin tanah = 18,26 ton/m<sup>2</sup>  
 Tegangan maks = 22,95 ton/m<sup>2</sup> > Tegangan izin tanah, Tidak aman  
 Tegangan min = 3,38 ton/m<sup>2</sup> < Tegangan izin tanah , Aman

Sumber: Hasil Perhitungan

Keterangan:

- [ 1 ] = lebar tiap bagian (m)
- [ 2 ] = tinggi tiap bagian (m)
- [ 3 ] = panjang konstruksi, tiap 1 meter panjang (m)
- [ 4 ] = 1 digunakan untuk penampang persegi atau persegi panjang  
= 0,5 digunakan untuk penampang segitiga
- [ 5 ] = berat jenis beton bertulang = 2,4 ( $t/m^3$ )  
= berat jenis tanah timbunan = 1,8 ( $t/m^3$ )  
= berat jenis tanah jenuh = 1,976 ( $t/m^3$ )  
= berat jenis air = 1,000 ( $t/m^3$ )
- [ 6 ] = gaya vertikal (ton)  
= [ 1 ] \* [ 2 ] \* [ 3 ] \* [ 4 ] \* [ 5 ]  
(untuk bangunan, timbunan dan uplift)  
nilai (+) untuk arah gaya ke bawah  
nilai (-) untuk arah gaya ke atas
- [ 7 ] = gaya horizontal (ton)  
= [ 6 ] \* kh , dengan kh = 0,15 (untuk tekanan air dinamis)  
=  $7/12 * [ 2 ]^2 * [ 5 ] * kh$  (untuk tekanan air dinamis)  
nilai (+) untuk arah gaya ke hilir  
nilai (-) untuk arah gaya ke hulu
- [ 8 ] = lengan momen gaya vertikal (m)
- [ 9 ] = lengan momen gaya horizontal (m)
- [ 10 ] = momen (ton.m)  
= [ 6 ] \* [ 8 ]
- [ 11 ] = momen (ton.m)  
= [ 7 ] \* [ 9 ]



Tabel 4.32. Rekapitulasi Stabilitas Dinding Penahan Bagian Jembatan

No.	Tinjauan analisa stabilitas	Angka keamanan terhadap guling		Angka keamanan terhadap geser		Eksentrisitas	L/6	Kontrol Eksentrisitas	Tegangan maks	Tegangan min	Tegangan izin	Kontrol Daya dukung
		SF Guling		SF Geser								
<b>A</b>	<b>Tinjauan Kondisi Normal</b>	SF > 1,5		SF > 1,5				$e \leq L/6$				< $\sigma$ izin
1	Muka Air Normal	3,763	Aman	2,183	Aman	0,807	1,833	Aman	21,184	8,239	18,258	Tidak Aman
2	Muka Air Banjir	3,555	Aman	2,053	Aman	0,900	1,833	Aman	21,666	7,396	18,258	Tidak Aman
<b>B</b>	<b>Tinjauan Kondisi Gempa</b>	SF > 1,2		SF > 1,2								
1	Muka Air Normal	3,056	Aman	1,473	Aman	1,259	1,833	Aman	22,512	4,184	18,258	Tidak Aman
2	Muka Air Banjir	2,903	Aman	1,404	Aman	1,363	1,833	Aman	22,955	3,380	18,258	Tidak Aman

Sumber: Hasil Perhitungan



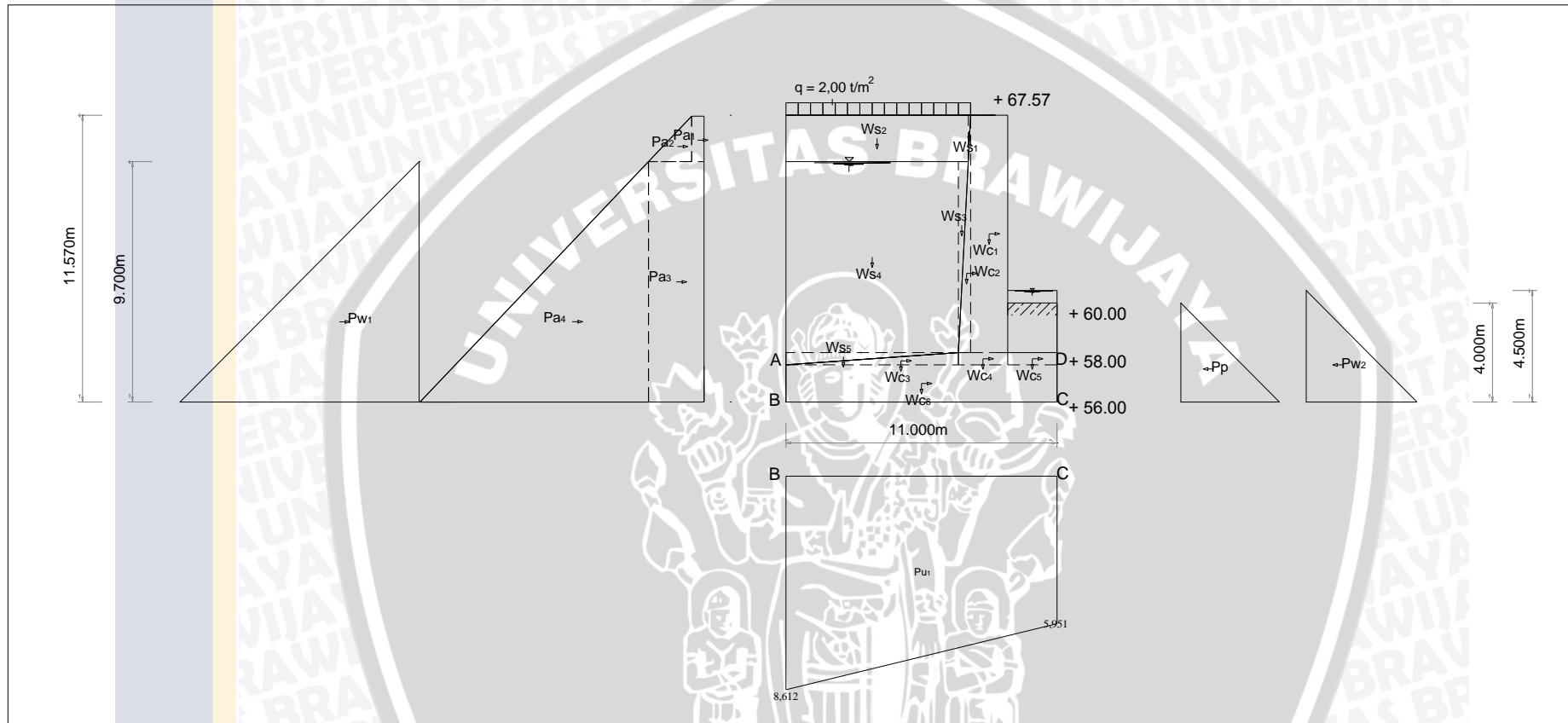

Gambar 4.24. Diagram Gaya Pada Dinding Penahan Tanah Jembatan Kondisi Muka Air Normal (Tanpa Gempa)

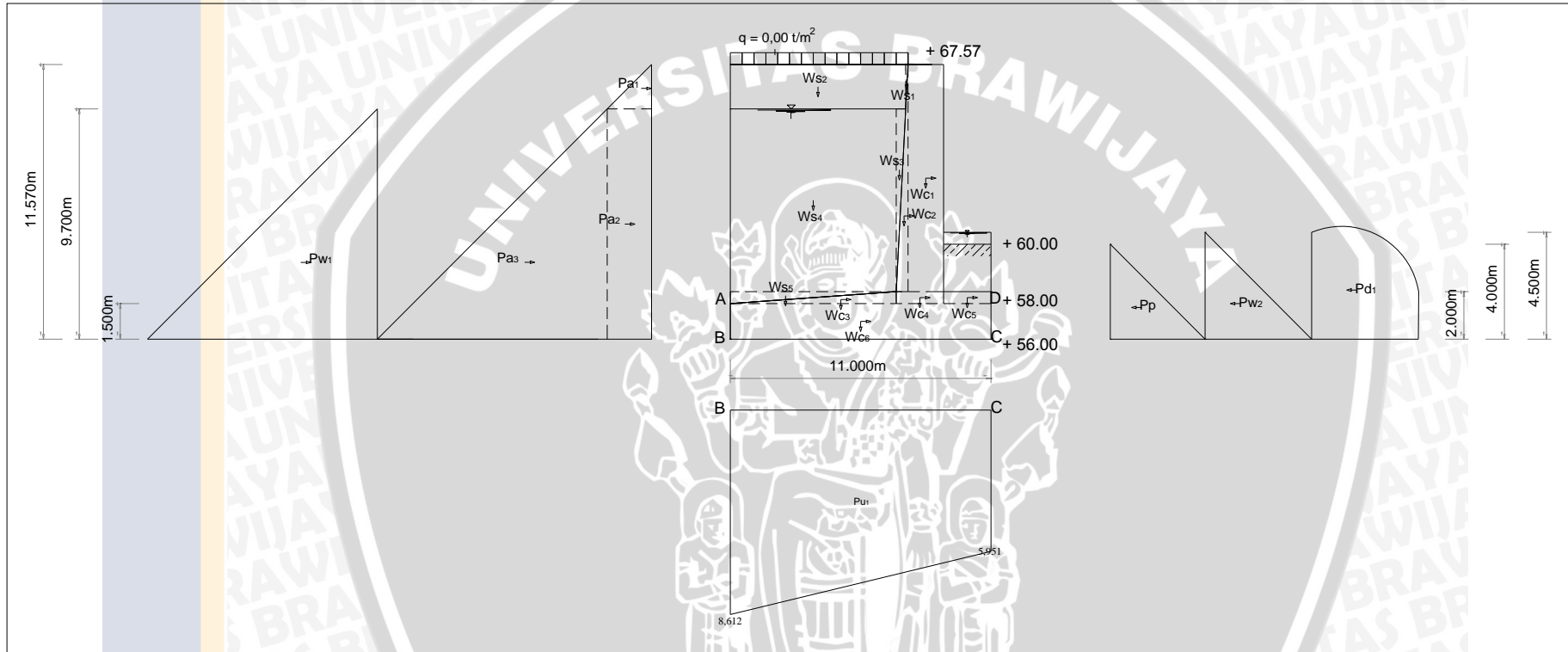

Gambar 4.25. Diagram Gaya Pada Dinding Penahan Tanah Jembatan Kondisi Muka Air Normal (Gempa)

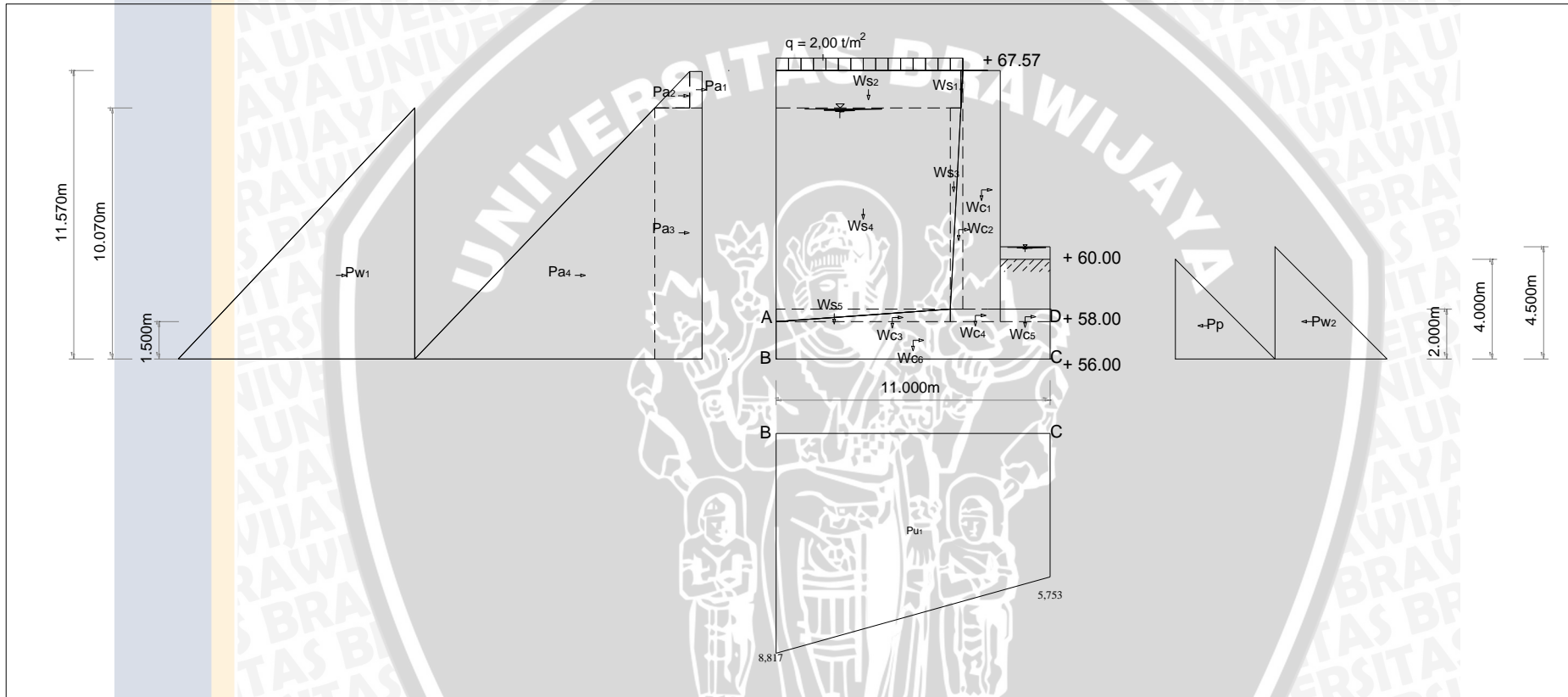

Gambar 4.26. Diagram Gaya Pada Dinding Penahan Tanah Jembatan Kondisi Muka Air Banjir (Tanpa Gempa)

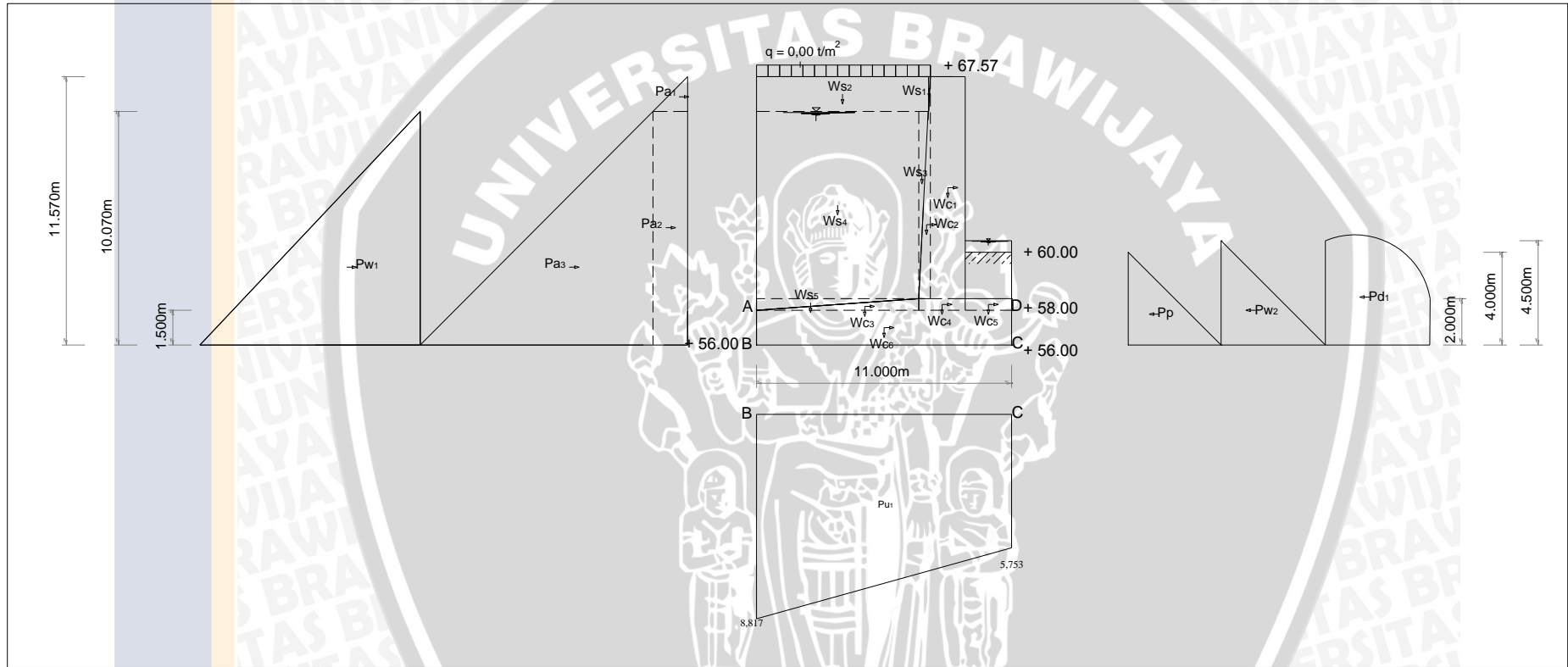

Gambar 4.27. Diagram Gaya Pada Dinding Penahan Tanah Jembatan Muka Air Banjir (Gempa)

#### 4.3.5. Dinding Penahan Tanah Bagian Hilir

Gaya berat dari dinding penahan disesuaikan dengan dimensi dari bangunan tersebut. Untuk mempermudah dalam perhitungan beban vertikal maka bangunan perlu dibagi menjadi bagian-bagian kecil yang disajikan secara visual seperti pada Gambar 4.28. dan Gambar 4.29. Perhitungan gaya berat pada dinding penahan tanah menggunakan persamaan (2-12) dapat dilihat pada Tabel 4.33.

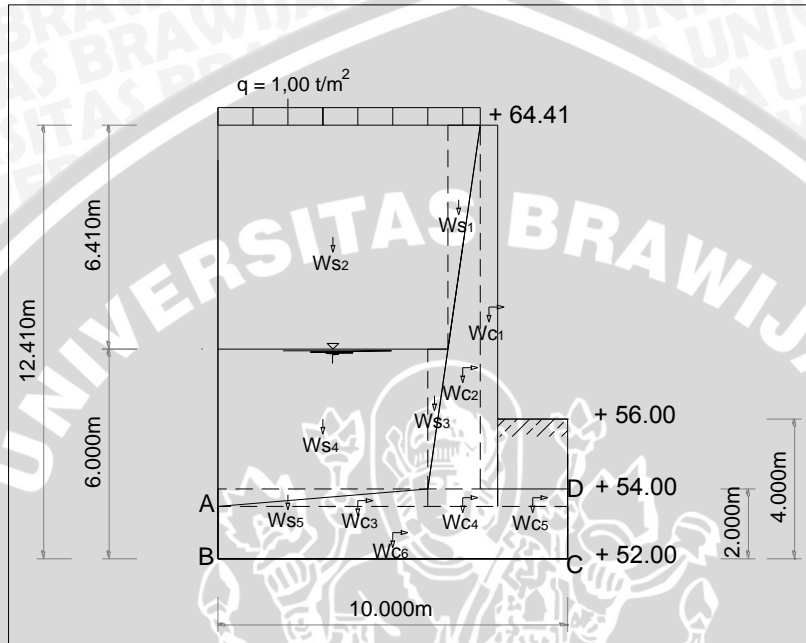

Gambar 4.28. Gaya Berat pada Dinding Penahan Tanah Bagian Hilir Kondisi Muka Air Normal

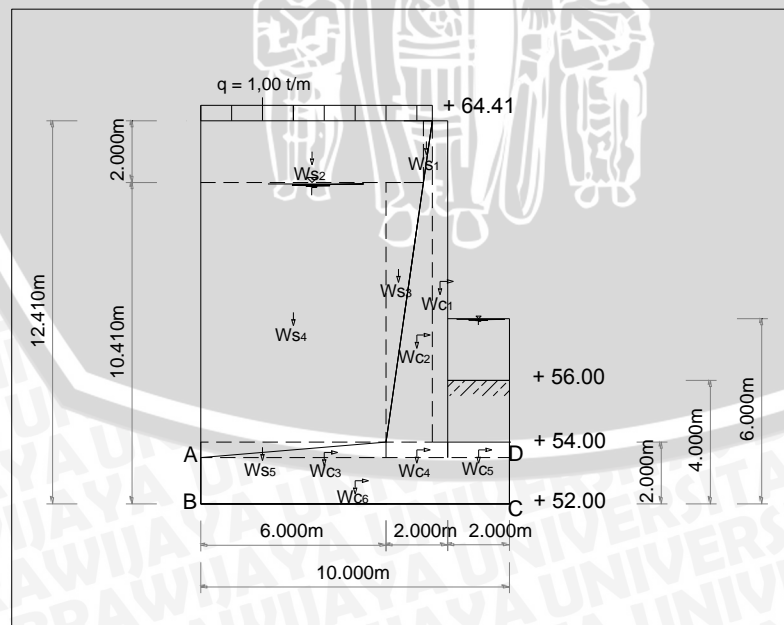

Gambar 4.29. Gaya Berat pada Dinding Penahan Tanah Bagian Hilir Kondisi Muka Air Banjir

**Tabel 4.33. Perhitungan Gaya Berat pada Dinding Penahan Tanah Bagian Hilir**

Notasi	Nilai				Volume	$\gamma$	Gaya Berat	
	Lebar	Tinggi	Panjang	Ratio				
		m	m	m	$m^3$	$(t/m^3)$	(t)	
	[ 1 ]	[ 2 ]	[ 3 ]	[ 4 ]	[ 5 ]	[ 6 ]	[ 7 ]	
$W_{c_1}$	0,500	10,410	1,000	1,000	5,205	2,400	12,492	
$W_{c_2}$	1,500	10,410	1,000	0,500	7,808	2,400	18,738	
$W_{c_3}$	6,000	0,500	1,000	0,500	1,500	2,400	3,600	
$W_{c_4}$	2,000	0,500	1,000	1,000	1,000	2,400	2,400	
$W_{c_5}$	2,000	0,500	1,000	1,000	1,000	2,400	2,400	
$W_{c_6}$	10,000	1,500	1,000	1,000	15,000	2,400	36,000	
Total								75,630

Sumber: Hasil Perhitungan

Keterangan:

[ 1 ] = lebar tiap bagian (m)

[ 2 ] = tinggi tiap bagian (m)

[ 3 ] = panjang konstruksi, tiap 1 meter panjang (m)

[ 4 ] = 1 digunakan untuk penampang persegi atau persegi panjang  
= 0,5 digunakan untuk penampang segitiga

[ 5 ] = volume ( $m^3$ )  
= [ 1 ] \* [ 2 ] \* [ 3 ] \* [ 4 ]

[ 6 ] = berat jenis beton bertulang = 2,4 ( $t/m^3$ )

[ 7 ] = gaya berat konstruksi (ton)  
= [ 5 ] \* [ 6 ]

Perhitungan *uplift* pada kondisi normal maupun pada kondisi banjir disajikan pada Tabel 4.34 dan 4.35. Perhitungan analisis stabilitas pada berbagai kondisi disajikan pada Tabel 4.36 sampai dengan Tabel 4.39. Diagram gaya yang bekerja pada dinding penahan tanah sesuai dengan kondisi yang dianalisis disajikan pada Gambar 4.30. sampai dengan Gambar 4.33. Rekapitulasi hasil perhitungan stabilitas dinding penahan bagian jembatan dengan berbagai kondisi yang telah dianalisis pada halaman sebelumnya, disajikan pada Tabel 4.40.

**Tabel 4.34. Perhitungan Gaya Uplift tiap titik pada Dinding Penahan Tanah Hilir Kondisi Muka Air Normal**

Panjang Creep = 6,833  
 Tinggi air di hulu = 6,000  
 Tinggi air di hilir = 4,000

Titik	Garis	Panjang Rembesan				$\Delta H$	Hx	Uplift
		Vertikal	Horizontal	1/3.Horiz ontal	Jarak			
		[ 1 ]	[ 2 ]	[ 3 ]	[ 4 ]			
A					0,000	0,000	4,500	4,500
	A-B	1,500						
B					1,500	0,439	6,000	5,561
	B-C		10,000	3,333				
C					4,833	1,415	6,000	4,585
	C-D	2,000						
D					6,833	2,000	4,000	2,000

Sumber: Hasil Perhitungan

$$\begin{aligned}
 C_w (\text{Lane}) &= \frac{L_w}{H_w} \\
 &= \frac{6,833}{2,000} \\
 &= 3,417
 \end{aligned}$$

Keterangan:

- [ 1 ] = panjang rembesan vertikal tiap garis (m)
  - [ 2 ] = panjang rembesan horizontal tiap garis (m)
  - [ 3 ] = [ 2 ] \* 1/3
  - [ 4 ] = jarak kumulatif di tiap titik (m)  
= [ 1 ]<sub>n</sub> + [ 3 ]<sub>n-1</sub>
  - [ 5 ] = pengurangan tekanan air (t/m)  
= Lw/Cw
  - [ 6 ] = jarak muka air ke titik x (t/m)
  - [ 7 ] = gaya uplift (t/m)  
= [ 6 ] - [ 5 ]
- Hw = Tinggi Energi hulu - tinggi energi di hilir  
= 2,000

**Tabel 4.35. Perhitungan Gaya Uplift tiap titik pada Dinding Penahan Tanah Hilir Kondisi Muka Air Banjir**

Panjang Creep = 6,833  
 Tinggi air di hulu = 10,410  
 Tinggi air di hilir = 6,000

Titik	Garis	Panjang Rembesan				$\Delta H$	Hx	Uplift
		Vertikal	Horizont al	1/3.Horiz ontal	Jarak			
		[ 1 ]	[ 2 ]	[ 3 ]	[ 4 ]			
A					0,000	0,000	8,910	8,910
	A-B	1,500						
B					1,500	0,968	10,410	9,442
	B-C		10,000	3,333				
C					4,833	3,119	10,410	7,291
	C-D	2,000						
D					6,833	4,410	8,410	4,000

Sumber: Hasil Perhitungan

$$\begin{aligned}
 C_w (\text{Lane}) &= \frac{L_w}{H_w} \\
 &= \frac{6,833}{4,410} \\
 &= 1,550
 \end{aligned}$$

Keterangan:

Keterangan:

- [ 1 ] = panjang rembesan vertikal tiap garis (m)  
 [ 2 ] = panjang rembesan horizontal tiap garis (m)  
 [ 3 ] = [ 2 ] \* 1/3  
 [ 4 ] = jarak komulatif di tiap titik (m)  
 = [ 1 ]<sub>n</sub> + [ 3 ]<sub>n-1</sub>  
 [ 5 ] = pengurangan tekanan air (t/m)  
 =  $L_w/C_w$   
 [ 6 ] = jarak muka air ke titik x (t/m)  
 [ 7 ] = gaya uplift (t/m)  
 = [ 6 ] - [ 5 ]

$$\begin{aligned}
 H_w &= \text{Tinggi Energi hulu} - \text{tinggi energi di hilir} \\
 &= 4,410
 \end{aligned}$$



**Tabel 4.36. Analisis Stabilitas Dinding Penahan Tanah Hilir Kondisi Muka Air Normal (Tanpa Gempa)**

Notasi	Nilai								Gaya		Lengan Momen		Momen			
	Lebar (m)		Tinggi (m)		Panjang (m)		Ratio		$\gamma$ (t/m <sup>3</sup> )	Pv (ton)	Ph (ton)	x (m)	y (m)	Mx (ton.m)	My (ton.m)	
	[1]		[2]		[3]		[4]		[5]	[6]	[7]	[8]	[9]	[10]	[11]	
Wc1	0,500	x	10,410	x	1,000	x	1,000		2,400	=	12,492		2,250		28,107	
Wc2	1,500	x	10,410	x	1,000	x	0,500		2,400	=	18,738		3,000		56,214	
Wc3	6,000	x	0,500	x	1,000	x	0,500		2,400	=	3,600		6,000		21,600	
Wc4	2,000	x	0,500	x	1,000	x	1,000		2,400	=	2,400		3,000		7,200	
Wc5	2,000	x	0,500	x	1,000	x	1,000		2,400	=	2,400		1,000		2,400	
Wc6	10,000	x	1,500	x	1,000	x	1,000		2,400	=	36,000		5,000		180,000	
Ws1	0,924	x	6,410	x	1,000	x	0,500		1,800	=	5,331		3,116		16,610	
Ws2	6,576	x	6,410	x	1,000	x	1,000		1,800	=	75,874		6,712		509,266	
Ws3	0,576	x	4,000	x	1,000	x	0,500		1,800	=	2,074		3,808		7,896	
Ws4	6,000	x	4,000	x	1,000	x	1,000		1,976	=	47,435		7,000		332,047	
Ws5	6,000	x	0,500	x	1,000	x	0,500		1,976	=	2,965		8,000		23,718	
q	7,500	x	1,000							=	7,500		6,250		46,875	
Pu1	10,000	x	4,585	x	1,000				1,000	=	-45,854		5,000		-229,268	
	10,000	x	0,976	x	1,000	x	0,500		1,000	=	-4,878		6,667		-32,520	
Pa1	Ka	x	q	x	h1					=						
	0,392	x	1,000	x	6,410					=		2,515	9,205		23,155	
Pa2	Ka	x	0,5	x	h1	x	h1	x	$\gamma$							
	0,392	x	0,500	x	6,410	x	6,410	x	1,800			14,512	8,137		118,078	
Pa3	(Ka	x	q	+	Ka	x	y	x	h1)	x	h2					
	(0,392	x	1,000	+	0,392	x	1,800	x	6,410)	x	6,000			29,522	3,000	88,565
Pa4	Ka	x	0,5	x	h2	x	h2	x	ysub							
	0,392	x	0,500	x	6,000	x	6,000	x	0,976			6,898	2,000		13,795	
Pw1	0,500	x	h2	x	h2				1,000	=						
	0,500	x	6,000	x	6,000				1,000	=		18,000	2,000		36,000	
Pp	Kp	x	0,500	x	h3	x	h3	x	ysub							
	2,601	x	0,500	x	4,000	x	4,000	x	0,976			-20,319	1,333		-27,092	
Pw2	0,500	x	h4	x	h4				1,000	=						
	0,500	x	4,000	x	4,000				1,000	=		-8,000	1,333		-10,667	
<b>TOTAL</b>									<b><math>\Sigma V</math></b>	<b>166,076</b>			<b><math>\Sigma Mv</math></b>	<b>970,144</b>		
									<b><math>\Sigma H</math></b>		<b>43,127</b>		<b><math>\Sigma Mh</math></b>		<b>241,834</b>	

Angka keamanan terhadap guling dan geser kondisi tanpa gempa :  
 SF Guling =  $\Sigma M v / \Sigma M h = 4,01 > 1,5$  Aman  
 SF Geser =  $=(f \cdot \Sigma V) / \Sigma H = 2,70 > 1,5$  Aman

Kontrol terhadap eksentrisitas dan daya dukung izin tanah :  
 Eksentrisitas :  
 $L = 10,000$  m  
 $e = 0,615 < L / 6 = 1,67$  Aman

$f = 0,70$   
 $\phi = 27,5^\circ$

Tegangan maksimum dan minimum yang terjadi di bawah dasar pondasi :  
 Tegangan izin tanah = 15,60 ton/m<sup>2</sup>  
 Tegangan maks = 22,73 ton/m<sup>2</sup> > Tegangan izin tanah, Tidak aman  
 Tegangan min = 10,48 ton/m<sup>2</sup> < Tegangan izin tanah, Aman

Sumber: Hasil Perhitungan

**Keterangan:**

- [ 1 ] = lebar tiap bagian (m)
- [ 2 ] = tinggi tiap bagian (m)
- [ 3 ] = panjang konstruksi, tiap 1 meter panjang (m)
- [ 4 ] = 1 digunakan untuk penampang persegi atau persegi panjang  
= 0,5 digunakan untuk penampang segitiga
- [ 5 ] = berat jenis beton bertulang = 2,4 (t/m<sup>3</sup>)  
= berat jenis tanah timbunan = 1,8 (t/m<sup>3</sup>)  
= berat jenis tanah jenuh = 1,976 (t/m<sup>3</sup>)  
= berat jenis air = 1,000 (t/m<sup>3</sup>)
- [ 6 ] = gaya vertikal (ton)  
= [ 1 ] \* [ 2 ] \* [ 3 ] \* [ 4 ] \* [ 5 ]  
(untuk bangunan, timbunan dan uplift)  
nilai (+) untuk arah gaya ke bawah  
nilai (-) untuk arah gaya ke atas
- [ 7 ] = gaya horizontal (ton)  
= [ 6 ] \* kh, dengan kh = 0,15 (untuk berat bangunan)  
=  $7/12 * [ 2 ]^2 * [ 5 ] * kh$  (untuk tekanan air dinamis)  
nilai (+) untuk arah gaya ke hilir  
nilai (-) untuk arah gaya ke hulu
- [ 8 ] = lengan momen gaya vertikal (m)
- [ 9 ] = lengan momen gaya horizontal (m)
- [ 10 ] = momen (ton.m)
- [ 11 ] = [ 6 ] \* [ 8 ]  
= [ 7 ] \* [ 9 ]



**Tabel 4.37. Analisis Stabilitas Dinding Penahan Tanah Hilir Kondisi Muka Air Normal (Gempa)**

Notasi	Nilai								Gaya		Lengan Momen		Momen			
	Lebar (m)	Tinggi (m)	Panjang (m)		Ratio			$\gamma$ (t/m <sup>3</sup> )	Pv (ton)	Ph (ton)	x (m)	y (m)	Mx (ton.m)	My (ton.m)		
	[1]	[2]	[3]	[4]				[5]	[6]	[7]	[8]	[9]	[10]	[11]		
Wc1	0,500	x	10,410	x	1,000	x	1,000		2,400	=	12,492	1,874	2,250	7,205	28,107	13,501
Wc2	1,500	x	10,410	x	1,000	x	0,500		2,400	=	18,738	2,811	3,000	5,470	56,214	15,375
Wc3	6,000	x	0,500	x	1,000	x	0,500		2,400	=	3,600	0,540	6,000	1,667	21,600	0,900
Wc4	2,000	x	0,500	x	1,000	x	1,000		2,400	=	2,400	0,360	3,000	1,750	7,200	0,630
Wc5	2,000	x	0,500	x	1,000	x	1,000		2,400	=	2,400	0,360	1,000	1,750	2,400	0,630
Wc6	10,000	x	1,500	x	1,000	x	1,000		2,400	=	36,000	5,400	5,000	0,750	180,000	4,050
Ws1	0,924	x	6,410	x	1,000	x	0,500		1,800	=	5,331		3,116		16,610	
Ws2	6,576	x	6,410	x	1,000	x	1,000		1,800	=	75,874		6,712		509,266	
Ws3	0,576	x	4,000	x	1,000	x	0,500		1,800	=	2,074		3,808		7,896	
Ws4	6,000	x	4,000	x	1,000	x	1,000		1,976	=	47,435		7,000		332,047	
Ws5	6,000	x	0,500	x	1,000	x	0,500		1,976	=	2,965		8,000		23,718	
Pu1	10,000	x	4,585	x	1,000				1,000	=	-45,854		5,000		-229,268	
	10,000	x	0,976	x	1,000	x	0,500		1,000	=	-4,878		6,667		-32,520	
Pae1	Kae	x	0,500	x	h <sub>1</sub>	x	h <sub>1</sub>	x	$\gamma$	=						
	0,408	x	0,500	x	6,410	x	6,410	x	1,800	=		15,076	8,137		122,67168	
Pae2	Kae	x	h <sub>1</sub>	x	h <sub>2</sub>	x	$\gamma$			=						
	0,408	x	6,410	x	6,000	x	1,800			=		28,224	3,000		84,672473	
Pae3	Kae	x	0,500	x	h <sub>2</sub>	x	h <sub>2</sub>	x	$\gamma_{sub}$	=						
	0,408	x	0,500	x	6,000	x	6,000	x	0,976	=		7,166	2,000		14,331804	
Pw1	0,500	x	h <sub>2</sub>	x	h <sub>2</sub>				1,000	=						
	0,500	x	6,000	x	6,000				1,000	=		18,000	2,000		36,000	
Ppe	Kpe	x	0,500	x	h <sub>3</sub>	x	h <sub>3</sub>	x	$\gamma_{sub}$	=						
	1,536	x	0,500	x	4,000	x	4,000	x	0,976	=		-11,996	1,333		-15,995	
Pw2	0,500	x	h <sub>4</sub>	x	h <sub>4</sub>				1,000	=						
	0,500	x	4,000	x	4,000				1,000	=		-8,000	1,333		-10,667	
Pd1	(7/12)	x	Kh	x	h	x	h			=						
	0,583	x	0,150	x	4,000	x	4,000		1,000	=		-1,400	1,333		-1,867	
<b>TOTAL</b>									<b><math>\Sigma V</math></b>		<b>158,576</b>		<b><math>\Sigma Mv</math></b>		<b>923,269</b>	
									<b><math>\Sigma H</math></b>		<b>58,415</b>		<b><math>\Sigma Mh</math></b>		<b>264,233</b>	

Angka keamanan terhadap guling dan geser kondisi gempa :  
 SF Guling =  $\Sigma M v / \Sigma M h = 3,49 > 1,2$  Aman  
 SF Geser =  $=(f \cdot \Sigma V) / \Sigma H = 1,90 > 1,2$  Aman  
 Kontrol terhadap eksentrisitas dan daya dukung izin tanah :  
 Eksentrisitas :  
 $L = 10,000$  m  
 $e = 0,844$  <  $L/6 = 1,67$  Aman  
 Tegangan maksimum dan minimum yang terjadi di bawah dasar pondasi :  
 Tegangan izin tanah = 15,60 ton/m<sup>2</sup>  
 Tegangan maks = 23,89 ton/m<sup>2</sup> > Tegangan izin tanah, Tidak aman  
 Tegangan min = 7,83 ton/m<sup>2</sup> < Tegangan izin tanah, Aman

Sumber: Hasil Perhitungan

**Keterangan:**

- [ 1 ] = lebar tiap bagian (m)
- [ 2 ] = tinggi tiap bagian (m)
- [ 3 ] = panjang konstruksi, tiap 1 meter panjang
- [ 4 ] = 1 digunakan untuk penampang persegi atau persegi panjang  
= 0,5 digunakan untuk penampang segitiga
- [ 5 ] = berat jenis beton bertulang = 2,4 (t/m<sup>3</sup>)  
= berat jenis tanah timbunan = 1,8 (t/m<sup>3</sup>)  
= berat jenis tanah jenuh = 1,976 (t/m<sup>3</sup>)  
= berat jenis air = 1,000 (t/m<sup>3</sup>)
- [ 6 ] = gaya vertikal (ton)  
= [ 1 ] \* [ 2 ] \* [ 3 ] \* [ 4 ] \* [ 5 ]  
(untuk bangunan, timbunan dan uplift)  
nilai (+) untuk arah gaya ke bawah  
nilai (-) untuk arah gaya ke atas
- [ 7 ] = gaya horizontal (ton)  
= [ 6 ] \* kh, dengan kh = 0,15 (untuk berat bangunan)  
= 7/12 \* [ 2 ]<sup>2</sup> \* [ 5 ] \* kh (untuk tekanan air dinamis)  
nilai (+) untuk arah gaya ke hilir  
nilai (-) untuk arah gaya ke hulu
- [ 8 ] = lengan momen gaya vertikal (m)
- [ 9 ] = lengan momen gaya horizontal (m)
- [ 10 ] = momen (ton.m)
- [ 11 ] = momen (ton.m)  
= [ 6 ] \* [ 8 ]  
= [ 7 ] \* [ 9 ]



**Tabel 4.38. Analisis Stabilitas Dinding Penahan Tanah Hilir Kondisi Muka Air Banjir (Tanpa Gempa)**

Notasi	Nilai						Gaya			Lengan Momen		Momen					
	Lebar (m)	Tinggi (m)	Panjang (m)	Ratio	Sudut $\theta$	$\gamma$ (t/m <sup>3</sup> )	Pv (ton)	Ph (ton)	x (m)	y (m)	Mx (ton.m)	My (ton.m)					
	[1]	[2]	[3]	[4]		[5]	[6]	[7]	[8]	[9]	[10]	[11]					
Wc1	0,500	x	10,410	x	1,000	x	1,000		2,400	=	12,492		2,250		28,107		
Wc2	1,500	x	10,410	x	1,000	x	0,500		2,400	=	18,738		3,000		56,214		
Wc3	6,000	x	0,500	x	1,000	x	0,500		2,400	=	3,600		6,000		21,600		
Wc4	2,000	x	0,500	x	1,000	x	1,000		2,400	=	2,400		3,000		7,200		
Wc5	2,000	x	0,500	x	1,000	x	1,000		2,400	=	2,400		1,000		2,400		
Wc6	10,000	x	1,500	x	1,000	x	1,000		2,400	=	36,000		5,000		180,000		
Ws1	0,288	x	2,000	x	1,000	x	0,500		1,800	=	0,518		2,692		1,396		
Ws2	7,212	x	2,000	x	1,000	x	1,000		1,800	=	25,963		6,394		166,009		
Ws3	1,212	x	8,410	x	1,000	x	0,500		1,800	=	9,174		3,596		32,988		
Ws4	6,000	x	8,410	x	1,000	x	1,000		1,976	=	99,733		7,000		698,129		
Ws5	6,000	x	0,500	x	1,000	x	0,500		1,976	=	2,965		8,000		23,718		
q	7,500	x	1,000							=	7,500		6,250		46,875		
Pu1	10,000	x	7,291	x	1,000				1,000	=	-72,907		5,000		-364,537		
	10,000	x	2,151	x	1,000	x	0,500		1,000	=	-10,756		6,667		-71,707		
Pa1	Ka	x	q	x	h <sub>1</sub>												
	0,392	x	1,000	x	2,000								0,785		11,410	8,955	
Pa2	Ka	x	0,5	x	h <sub>1</sub>	x	h <sub>1</sub>	x	$\gamma$								
	0,392	x	0,500	x	2,000	x	2,000	x	1,800				1,413		11,077	15,649	
Pa3	(Ka	x	q	+ Ka	x	$\gamma$	x	h <sub>1</sub> )	x	h <sub>2</sub>							
	(0,392	x	1,000	+ 0,392	x	1,800	x	2,000)	x	10,410					18,792	5,205	97,812
Pa4	Ka	x	0,5	x	h <sub>2</sub>	x	h <sub>2</sub>	x	$\gamma_{sub}$								
	0,392	x	0,500	x	10,410	x	10,410	x	0,976				20,763		3,470	72,048	
Pw1	0,500	x	h <sub>2</sub>	x	h <sub>2</sub>				1,000	=							
	0,500	x	10,410	x	10,410				1,000	=			54,184		3,470	188,019	
Pp	Kp	x	0,500	x	h <sub>3</sub>	x	h <sub>3</sub>	x	$\gamma_{sub}$								
	2,601	x	0,500	x	4,000	x	4,000	x	0,976				-20,319		1,333	-27,092	
Pw2	0,500	x	h <sub>4</sub>	x	h <sub>4</sub>				1,000	=							
	0,500	x	6,000	x	6,000				1,000	=			-18,000		2,000	-36,000	
<b>TOTAL</b>									<b><math>\Sigma V</math></b>		<b>137,819</b>		<b><math>\Sigma Mv</math></b>		<b>828,391</b>		
									<b><math>\Sigma H</math></b>		<b>57,617</b>		<b><math>\Sigma Mh</math></b>		<b>245,829</b>		
<p>Angka keamanan terhadap guling dan geser kondisi tanpa gempa :</p> <p>SF Guling = <math>\Sigma Mv / \Sigma Mh = 3,37 &gt; 1,5</math> Aman</p> <p>SF Geser = <math>=(f \cdot \Sigma V) / \Sigma H = 1,67 &gt; 1,5</math> Aman</p> <p>Kontrol terhadap eksentrisitas dan daya dukung izin tanah :</p> <p>Eksentrisitas :</p> <p>L = 10,000 m</p> <p>e = 0,773 &lt; L / 6 = 1,67 Aman</p> <p>f = 0,70</p> <p><math>\theta = 27,5^\circ</math></p> <p>Tegangan maksimum dan minimum yang terjadi di bawah dasar pondasi :</p> <p>Tegangan izin tanah = 15,60 ton/m<sup>2</sup></p> <p>Tegangan maks = 20,17 ton/m<sup>2</sup> &gt; Tegangan izin tanah, Tidak aman</p> <p>Tegangan min = 7,39 ton/m<sup>2</sup> &lt; Tegangan izin tanah, Aman</p>																	

Sumber: Hasil Perhitungan

Keterangan:

- |  |   |
|--|---|
| [ 1 ] = lebar tiap bagian (m)                                    | [ 7 ] = gaya horizontal (ton)                               |
| [ 2 ] = tinggi tiap bagian (m)                                   | = [ 6 ] * kh , dengan kh = 0,15 (untuk berat bangunan)      |
| [ 3 ] = panjang konstruksi, tiap 1 meter panjang (m)             | = $7/12 * [ 2 ]^2 * [ 5 ] * kh$ (untuk tekanan air dinamis) |
| [ 4 ] = 1 digunakan untuk penampang persegi atau persegi panjang | nilai (+) untuk arah gaya ke hilir                          |
| = 0,5 digunakan untuk penampang segitiga                         | nilai (-) untuk arah gaya ke hulu                           |
| [ 5 ] = berat jenis beton bertulang = 2,4 (t/m <sup>3</sup> )    | [ 8 ] = lengan momen gaya vertikal (m)                      |
| = berat jenis tanah timbunan = 1,8 (t/m <sup>3</sup> )           | [ 9 ] = lengan momen gaya horizontal (m)                    |
| = berat jenis tanah jenuh = 1,976 (t/m <sup>3</sup> )            | [ 10 ] = momen (ton.m)                                      |
| = berat jenis air = 1,000 (t/m <sup>3</sup> )                    | = [ 6 ] * [ 8 ]   |
| [ 6 ] = gaya vertikal (ton)                                      | [ 11 ] = momen (ton.m)                                      |
| = [ 1 ] * [ 2 ] * [ 3 ] * [ 4 ] * [ 5 ]                          | = [ 7 ] * [ 9 ]   |
| (untuk bangunan, timbunan dan uplift)                            |   |
| nilai (+) untuk arah gaya ke bawah                               |   |
| nilai (-) untuk arah gaya ke atas                                |   |

**Tabel 4.39. Analisis Stabilitas Dinding Penahan Tanah Hilir Kondisi Muka Air Banjir (Gempa)**

Notasi	Nilai								Gaya		Lengan Momen		Momen				
	Lebar (m)	Tinggi (m)	Panjang (m)		Ratio	Sudut $\theta$	$\gamma$ (t/m <sup>3</sup> )	Pv (ton)	Ph (ton)	x (m)	y (m)	Mx (ton.m)	My (ton.m)				
	[1]	[2]	[3]	[4]			[5]	[6]	[7]	[8]	[9]	[10]	[11]				
Wc1	0,500	x	10,410	x	1,000	x	1,000			2,400	=	12,492	1,874	2,250	7,205	28,107	13,501
Wc2	1,500	x	10,410	x	1,000	x	0,500			2,400	=	18,738	2,811	3,000	5,470	56,214	15,375
Wc3	6,000	x	0,500	x	1,000	x	0,500			2,400	=	3,600	0,540	6,000	1,667	21,600	0,900
Wc4	2,000	x	0,500	x	1,000	x	1,000			2,400	=	2,400	0,360	3,000	1,750	7,200	0,630
Wc5	2,000	x	0,500	x	1,000	x	1,000			2,400	=	2,400	0,360	1,000	1,750	2,400	0,630
Wc6	10,000	x	1,500	x	1,000	x	1,000			2,400	=	36,000	5,400	5,000	0,750	180,000	4,050
Ws1	0,288	x	2,000	x	1,000	x	0,500			1,800	=	0,518		2,692		1,396	
Ws2	7,212	x	2,000	x	1,000	x	1,000			1,800	=	25,963		6,394		166,009	
Ws3	1,212	x	8,410	x	1,000	x	0,500			1,800	=	9,174		3,596		32,988	
Ws4	6,000	x	8,410	x	1,000	x	1,000			1,976	=	99,733		7,000		698,129	
Ws5	6,000	x	0,500	x	1,000	x	0,500			1,976	=	2,965		8,000		23,718	
Pu1	10,000	x	7,291	x	1,000					1,000	=	-72,907		5,000		-364,537	
	10,000	x	2,151	x	1,000	x	0,500			1,000	=	-10,756		6,667		-71,707	
Paer	Kae	x	0,500	x	h <sub>1</sub>	x	h <sub>1</sub>	x	$\gamma$		=						
	0,408	x	0,500	x	2,000	x	2,000	x	1,800		=		1,468		11,077		16,257389
Paer2	Kae	x	h <sub>1</sub>	x	h <sub>2</sub>	x	h <sub>2</sub>	x	$\gamma$		=						
	0,408	x	2,000	x	10,410	x	1,800				=		15,279		5,205		79,526738
Paer3	Kae	x	0,500	x	h <sub>2</sub>	x	h <sub>2</sub>	x	$\gamma_{sub}$		=						
	0,408	x	0,500	x	10,410	x	10,410	x	0,976		=		21,571		3,470		74,851294
Pw1	0,500	x	h <sub>2</sub>	x	h <sub>2</sub>					1,000	=						
	0,500	x	10,410	x	10,410					1,000	=		54,184		3,470		188,01865
Ppe	Kpe	x	0,500	x	h <sub>3</sub>	x	h <sub>3</sub>	x	$\gamma_{sub}$		=						
	1,536	x	0,500	x	4,000	x	4,000	x	0,976		=		-11,996		1,333		-15,99517
Pw2	0,500	x	h <sub>4</sub>	x	h <sub>4</sub>					1,000	=						
	0,500	x	6,000	x	6,000					1,000	=		-18,000		2,000		-36
Pd1	(7/12	x	Kh	x	h <sub>4</sub>	x	h <sub>4</sub>				=						
	0,583	x	0,150	x	6,000	x	6,000			1,000	=		-3,150		2,000		-6,3
<b>TOTAL</b>										<b><math>\Sigma V</math></b>		<b>130,319</b>	<b>70,700</b>		<b><math>\Sigma Mv</math></b>	<b>781,516</b>	<b>335,444</b>
										<b><math>\Sigma H</math></b>					<b><math>\Sigma Mh</math></b>		

Angka keamanan terhadap guling dan geser kondisi gempa :  
 SF Guling =  $\Sigma M_v / \Sigma M_h = 2,33 > 1,2$  Aman  
 SF Geser =  $-(f \cdot \Sigma V) / \Sigma H = 1,29 > 1,2$  Aman  
 Kontrol terhadap eksentrisitas dan daya dukung izin tanah :  
 Eksentrisitas :  
 $L = 10,000$  m  
 $e = 1,577$  <  $L/6 = 1,67$  Aman  
 $f = 0,70$   
 $\phi = 27,5^\circ$   
 Tegangan maksimum dan minimum yang terjadi di bawah dasar pondasi :  
 Tegangan izin tanah = 15,60 ton/m<sup>2</sup>  
 Tegangan maks = 25,36 ton/m<sup>2</sup> > Tegangan izin tanah, Tidak aman  
 Tegangan min = 0,70 ton/m<sup>2</sup> < Tegangan izin tanah, Aman

Sumber: Hasil Perhitungan

Keterangan:

- [ 1 ] = lebar tiap bagian (m)
- [ 2 ] = tinggi tiap bagian (m)
- [ 3 ] = panjang konstruksi, tiap 1 meter panjang (m)
- [ 4 ] = 1 digunakan untuk penampang persegi atau persegi panjang  
= 0,5 digunakan untuk penampang segitiga
- [ 5 ] = berat jenis beton bertulang = 2,4 (t/m<sup>3</sup>)  
= berat jenis tanah timbunan = 1,8 (t/m<sup>3</sup>)  
= berat jenis tanah jenuh = 1,976 (t/m<sup>3</sup>)  
= berat jenis air = 1,000 (t/m<sup>3</sup>)
- [ 6 ] = gaya vertikal (ton)  
= [ 1 ] \* [ 2 ] \* [ 3 ] \* [ 4 ] \* [ 5 ]  
(untuk bangunan, timbunan dan uplift)  
nilai (+) untuk arah gaya ke bawah  
nilai (-) untuk arah gaya ke atas
- [ 7 ] = gaya horizontal (ton)  
= [ 6 ] \* kh, dengan kh = 0,15 (untuk berat bangunan)  
=  $7/12 * [ 2 ]^2 * [ 5 ] * kh$  (untuk tekanan air dinamis)  
nilai (+) untuk arah gaya ke hilir  
nilai (-) untuk arah gaya ke hulu
- [ 8 ] = lengan momen gaya vertikal (m)
- [ 9 ] = lengan momen gaya horizontal (m)
- [ 10 ] = momen (ton.m)
- [ 11 ] = momen (ton.m)  
= [ 7 ] \* [ 9 ]

Tabel 4.40. Rekapitulasi Stabilitas Dinding Penahan Bagian Hilir

No.	Tinjauan analisa stabilitas	Angka keamanan terhadap guling		Angka keamanan terhadap geser		Eksentrisitas	L/6	Kontrol Eksentrisitas	Tegangan maks	Tegangan min	Tegangan izin	Kontrol Daya dukung
		SF Guling		SF Geser								
<b>A</b>	<b>Tinjauan Kondisi Normal</b>	SF > 1,5		SF > 1,5				$e \leq L/6$				
1	Muka Air Normal	4,012	Aman	2,696	Aman	0,615	1,667	Aman	22,732	10,483	15,595	Tidak Aman
2	Muka Air Banjir	3,370	Aman	1,674	Aman	0,773	1,667	Aman	20,174	7,390	15,595	Tidak Aman
<b>B</b>	<b>Tinjauan Kondisi Gempa</b>	SF > 1,2		SF > 1,2								
1	Muka Air Normal	3,494	Aman	1,900	Aman	0,844	1,667	Aman	23,888	7,827	15,595	Tidak Aman
2	Muka Air Banjir	2,330	Aman	1,290	Aman	1,577	1,667	Aman	25,363	0,700	15,595	Tidak Aman

Sumber. Hasil Perhitungan

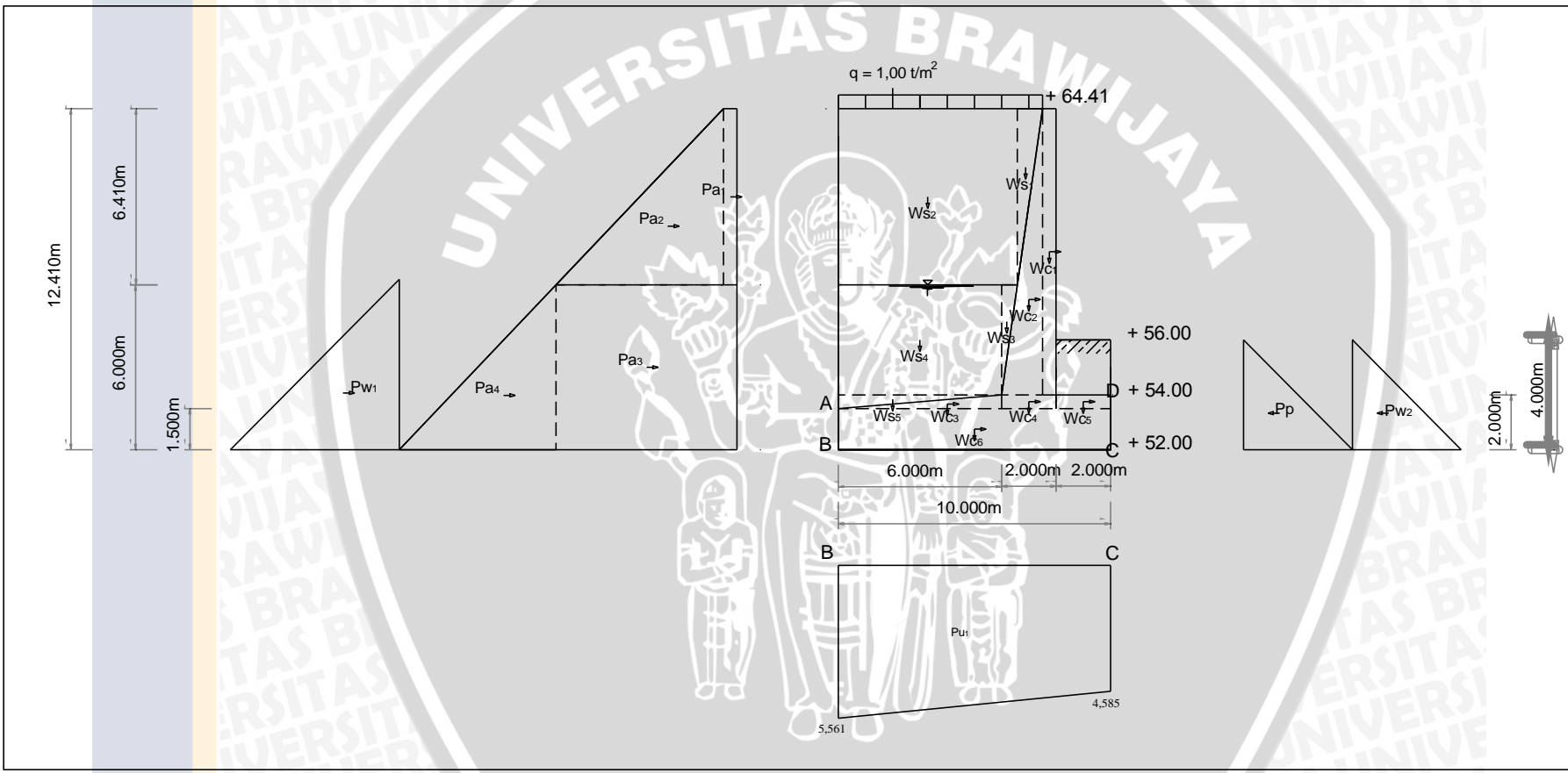

Gambar 4.30. Diagram Gaya Pada Dinding Penahan Tanah Jembatan Kondisi Muka Air Normal (Tanpa Gempa)

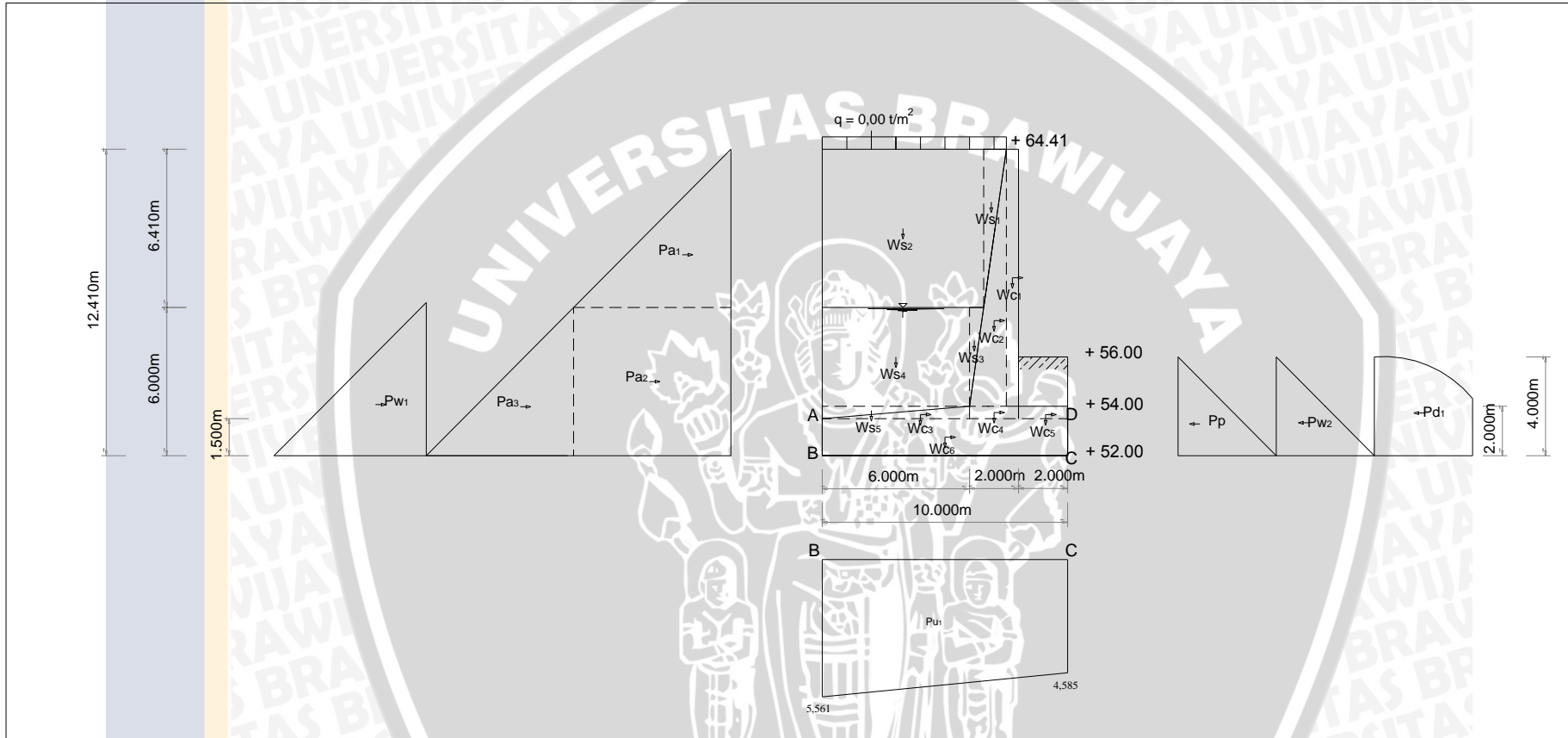

Gambar 4.31. Diagram Gaya Pada Dinding Penahan Tanah Jembatan Kondisi Muka Air Normal (Gempa)

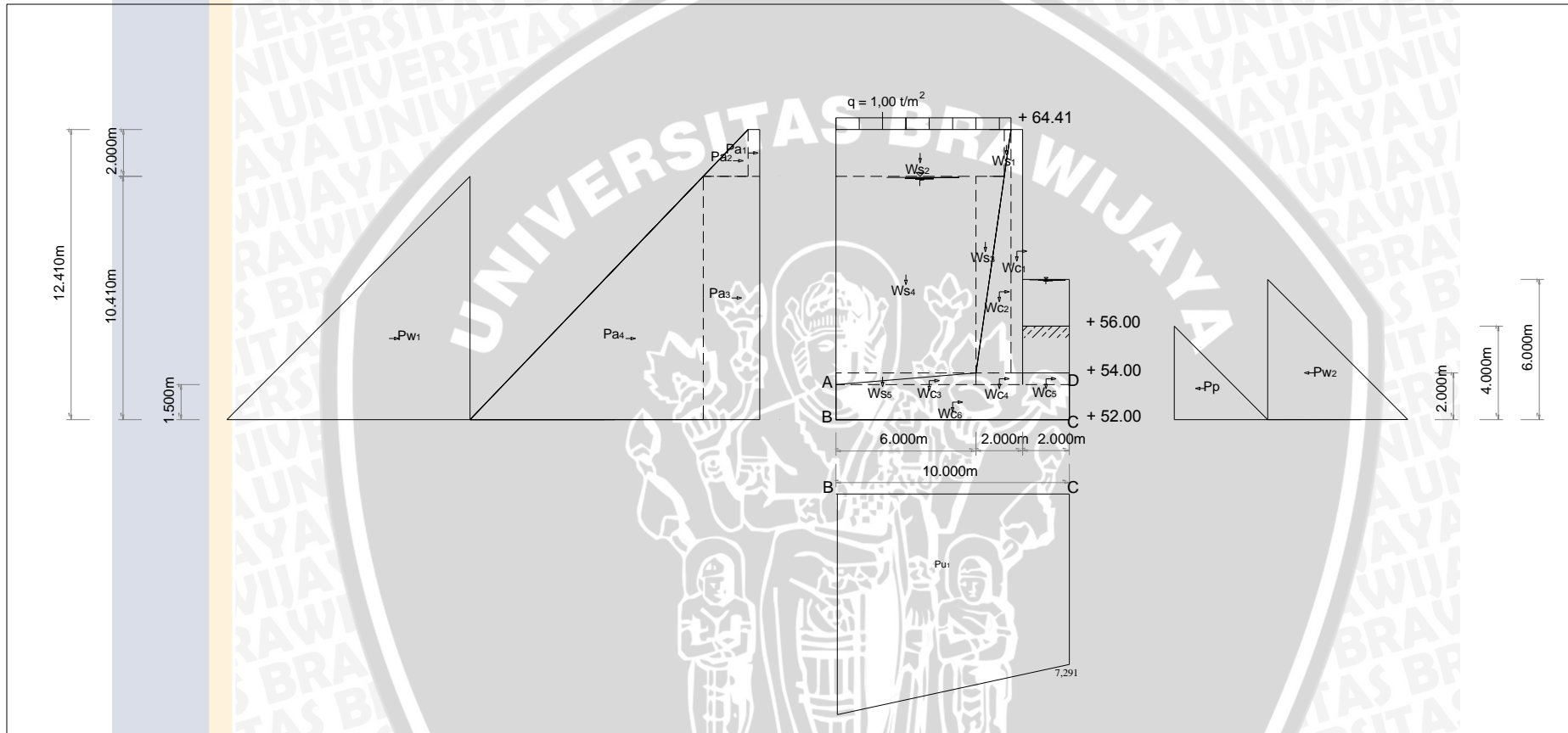

Gambar 4.32. Diagram Gaya Pada Dinding Penahan Tanah Jembatan Kondisi Muka Air Banjir (Tanpa Gempa)



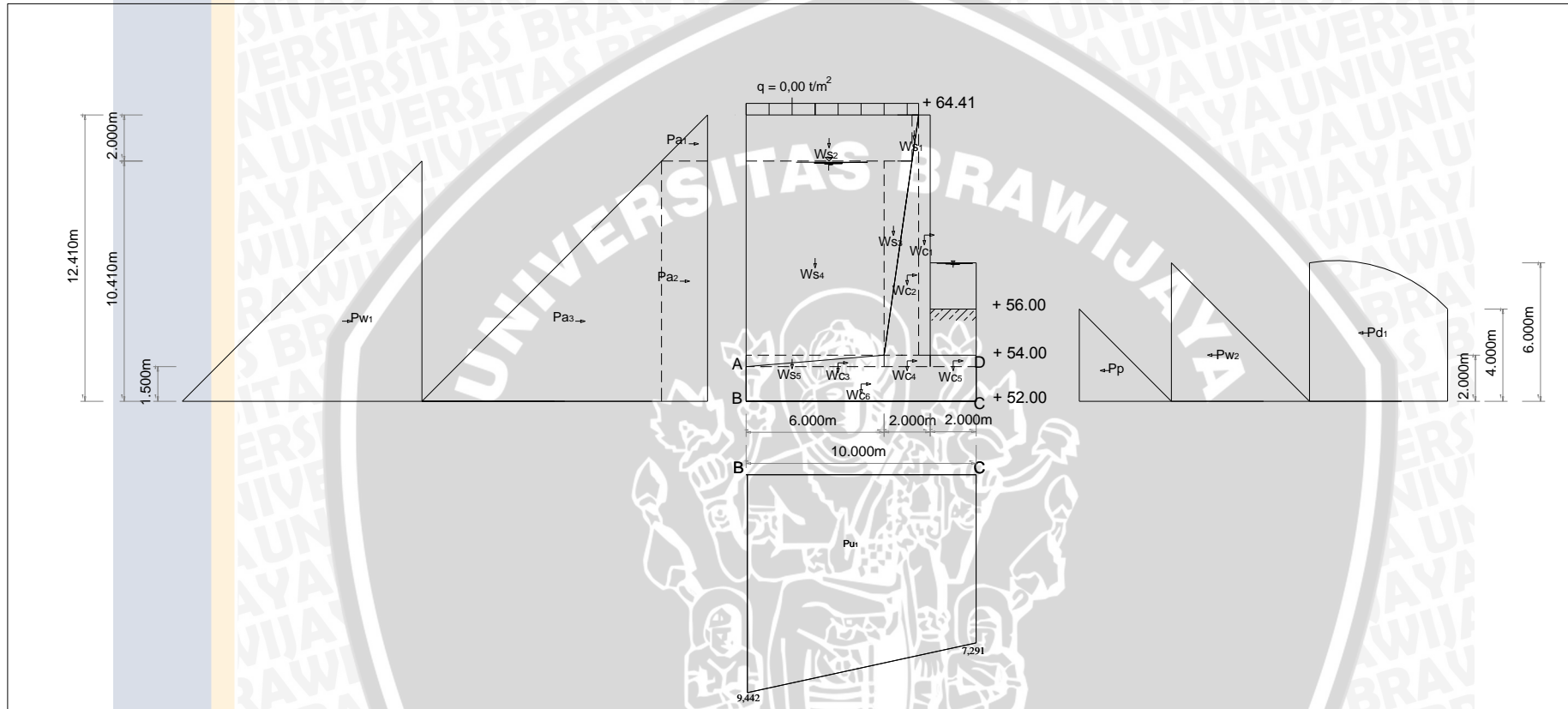

Gambar 4.33. Diagram Gaya Pada Dinding Penahan Tanah Jembatan Kondisi Muka Air Banjir (Gempa)

#### 4.3.6. Keamanan Tebal Lantai Bendung Gerak (*Barrage*)

Tebal lantai pada peredam energi bendung gerak (*barrage*) perlu diperhatikan keamanannya untuk menghindari terjadi kerusakan pada lantai tersebut. Ketebalan lantai dapat dikontrol menggunakan persamaan (2-11). Perhitungan keamanan tebal lantai sebagai berikut:

dimana:

$$\begin{aligned} dx &= \text{tebal lantai pada titik } x \text{ (m)} \\ &= 4,003 \text{ m} \end{aligned}$$

$$\begin{aligned} Px &= \text{gaya angkat pada titik } x \text{ (ton/m}^2\text{)} \\ &= 8,115 \text{ (ton/m}^2\text{)} \end{aligned}$$

$$\begin{aligned} Wx &= \text{kedalaman air pada titik } x \text{ (m)} \\ &= 2,000 \text{ m} \end{aligned}$$

$$\begin{aligned} \gamma &= \text{berat jenis bahan (ton/m}^3\text{)} \\ &= 2,400 \text{ (ton/m}^3\text{)} \end{aligned}$$

$$\begin{aligned} S &= \text{faktor keamanan} \\ &= 1,5 \text{ m} \end{aligned}$$

$$dx \geq S \frac{Px - Wx}{\gamma} :$$

$$4,003 \geq 1,5 \frac{8,115 - 2,000}{2,400}$$

$$4,003 \geq 3,822 \dots\dots\dots \text{memenuhi syarat}$$

Untuk mempermudah dalam perhitungan beban vertikal maka bangunan disajikan secara visual seperti pada Gambar 4.29. dan Gambar 4.30. Sedangkan perhitungan keamanan tebal lantai dapat dilihat pada Tabel.4.41. dan Tabel 4.42.

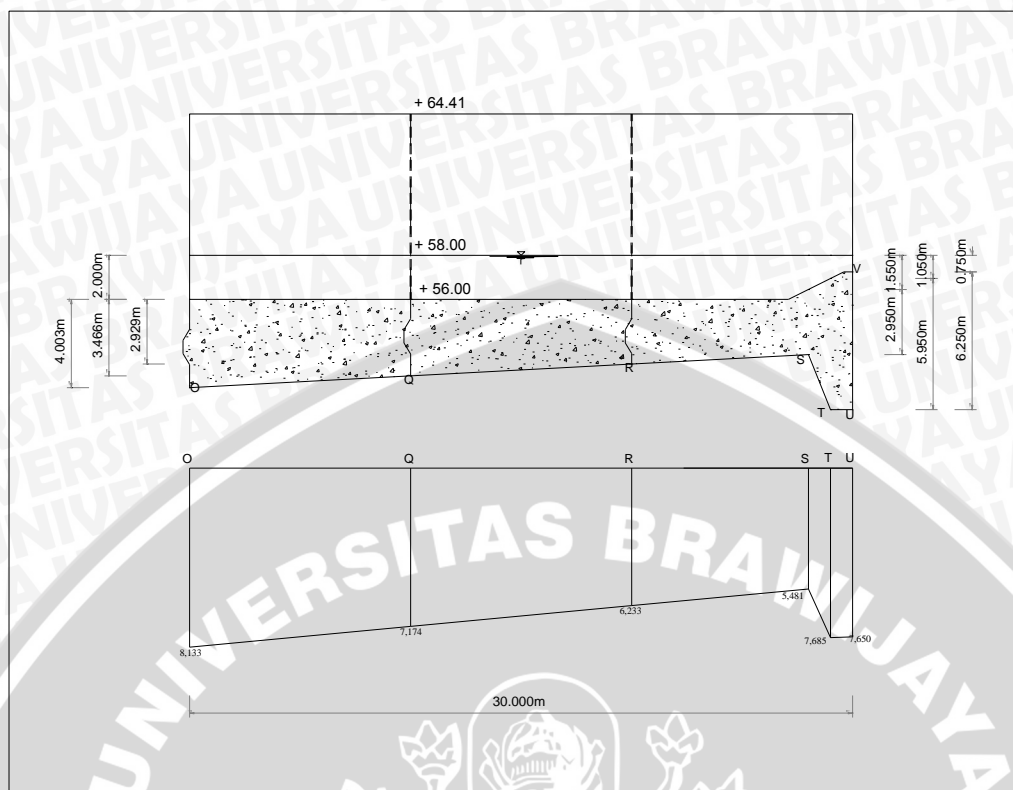

**Gambar 4.34. Tebal Lantai pada Kondisi Muka Air Normal**

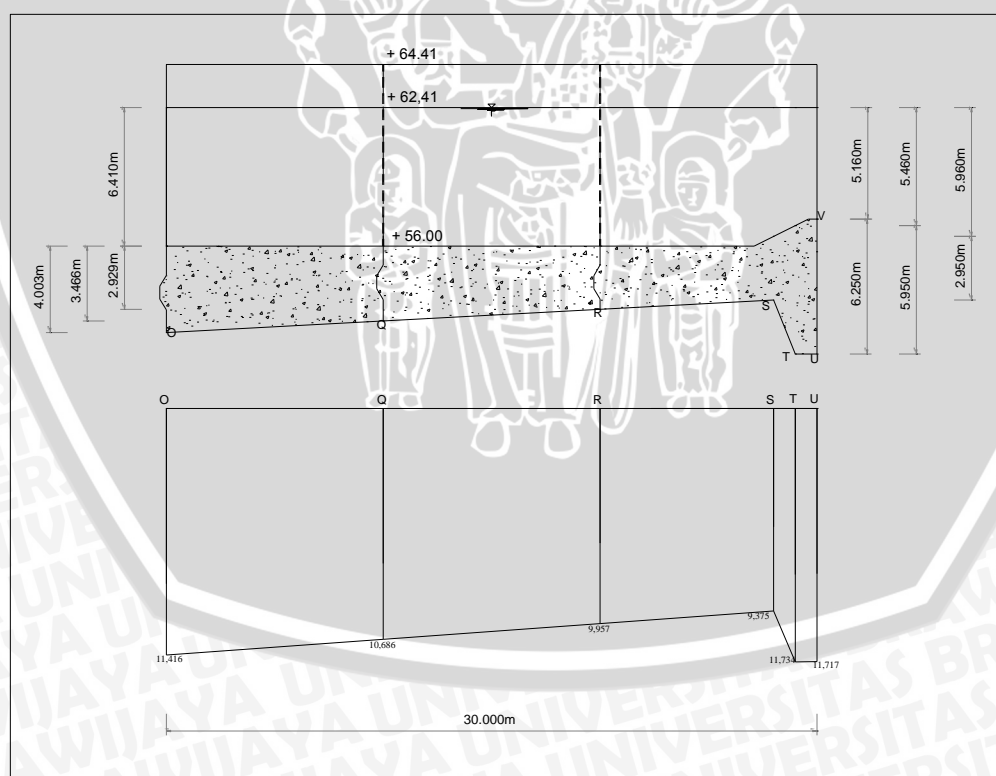

**Gambar 4.35. Tebal Lantai pada Kondisi Muka Air Banjir**

Tabel 4.41. Perhitungan Keamanan Tebal Lantai Kondisi Muka Air Normal

No.	Titik	Px	Wx	$\gamma$	S = 1,5	S . $\frac{Px - Wx}{\gamma}$	dx	Kontrol Keamanan Tebal Lantai
		(ton/m <sup>2</sup> )	(m)	(ton/m <sup>3</sup> )			(ton/m <sup>2</sup> )	
		[1]	[2]	[3]			[4]	
1	O	8,115	2,000	2,400	1,500	3,822	4,003	Aman
2	Q	7,174	2,000	2,400	1,500	3,234	3,466	Aman
3	R	6,233	2,000	2,400	1,500	2,646	2,929	Aman
4	S	5,481	1,550	2,400	1,500	2,457	2,950	Aman
5	T	7,685	1,050	2,400	1,500	4,147	5,950	Aman
6	U	7,650	0,750	2,400	1,500	4,312	6,250	Aman

Sumber: Hasil Perhitungan

Keterangan:

- [ 1 ] = uplift yang timbul pada titik x (ton/m<sup>2</sup>)
- [ 2 ] = kedalaman air pada titik x (m)
- [ 3 ] = berat jenis bahan (ton/m<sup>3</sup>)  
= 2,400 ton/m<sup>3</sup>
- [ 4 ] = faktor keamanan  
= 1,5 (Normal)
- [ 5 ] = [ 4 ](( [ 1 ] - [ 2 ] ) / [ 3 ])
- [ 6 ] = tebal lantai pada titik x (ton/m<sup>2</sup>)
- [ 7 ] = [ 6 ] ≥ [ 5 ] (Aman)

Tabel 4.42. Perhitungan Keamanan Tebal Lantai Kondisi Muka Air Banjir

No.	Titik	Px	Wx	$\gamma$	S = 1,25	S	$\frac{Px - Wx}{\gamma}$	dx	Kontrol Keamanan Tebal Lantai
		(ton/m <sup>2</sup> )	(m)	(ton/m <sup>3</sup> )				(ton/m <sup>2</sup> )	
		[1]	[2]	[3]			[4]	[5]	
1	O	11,416	6,410	2,400	1,250	2,607	4,003	Aman	
2	Q	10,686	6,410	2,400	1,250	2,227	3,466	Aman	
3	R	9,957	6,410	2,400	1,250	1,848	2,929	Aman	
4	S	9,375	5,960	2,400	1,250	1,778	2,950	Aman	
5	T	11,734	5,460	2,400	1,250	3,268	5,950	Aman	
6	U	11,717	5,160	2,400	1,250	3,415	6,250	Aman	

Sumber: Hasil Perhitungan

Keterangan:

- [ 1 ] = Uplift yang timbul pada titik x (ton/m<sup>2</sup>)  
 [ 2 ] = Kedalaman air pada titik x (m)  
 [ 3 ] = Berat jenis bahan (ton/m<sup>3</sup>)  
 = 2,400 ton/m<sup>3</sup>  
 [ 4 ] = Faktor keamanan  
 = 1,25 (Normal)  
 [ 5 ] = [ 4 ](( [ 1 ] - [ 2 ] ) / [ 3 ])  
 [ 6 ] = Tebal lantai pada titik x (ton/m<sup>2</sup>)  
 [ 7 ] = [ 6 ] ≥ [ 5 ] (Aman)

#### 4.3.7. Keamanan Tebal Lantai Bangunan Penguras (*Sluice Gate*)

Tebal lantai pada peredam energi bangunan penguras (*sluice gate*) perlu diperhatikan keamanannya untuk menghindari terjadi kerusakan pada lantai tersebut. Ketebalan lantai dapat dikontrol menggunakan persamaan (2-11). Perhitungan keamanan tebal lantai sebagai berikut:

dimana:

$d_x$  = tebal lantai pada titik x (m)

= 4,003 m

$P_x$  = gaya angkat pada titik x ( $\text{ton/m}^2$ )

= 8,133 ( $\text{ton/m}^2$ )

$W_x$  = kedalaman air pada titik x (m)

= 2,000 m

$\gamma$  = berat jenis bahan ( $\text{ton/m}^3$ )

= 2,400 ( $\text{ton/m}^3$ )

$S$  = faktor keamanan

= 1,5 m

$$d_x \geq S \frac{P_x - W_x}{\gamma} \quad :$$

$$4,003 \geq 1,5 \frac{8,133 - 2,000}{2,400}$$

$$4,003 \geq 3,833 \dots \dots \dots \text{memenuhi syarat}$$

Untuk mempermudah dalam perhitungan beban vertikal maka bangunan disajikan secara visual seperti pada Gambar 4.36 dan Gambar 4.37. Sedangkan perhitungan keamanan tebal lantai dapat dilihat pada Tabel.4.43. dan Tabel 4.44.

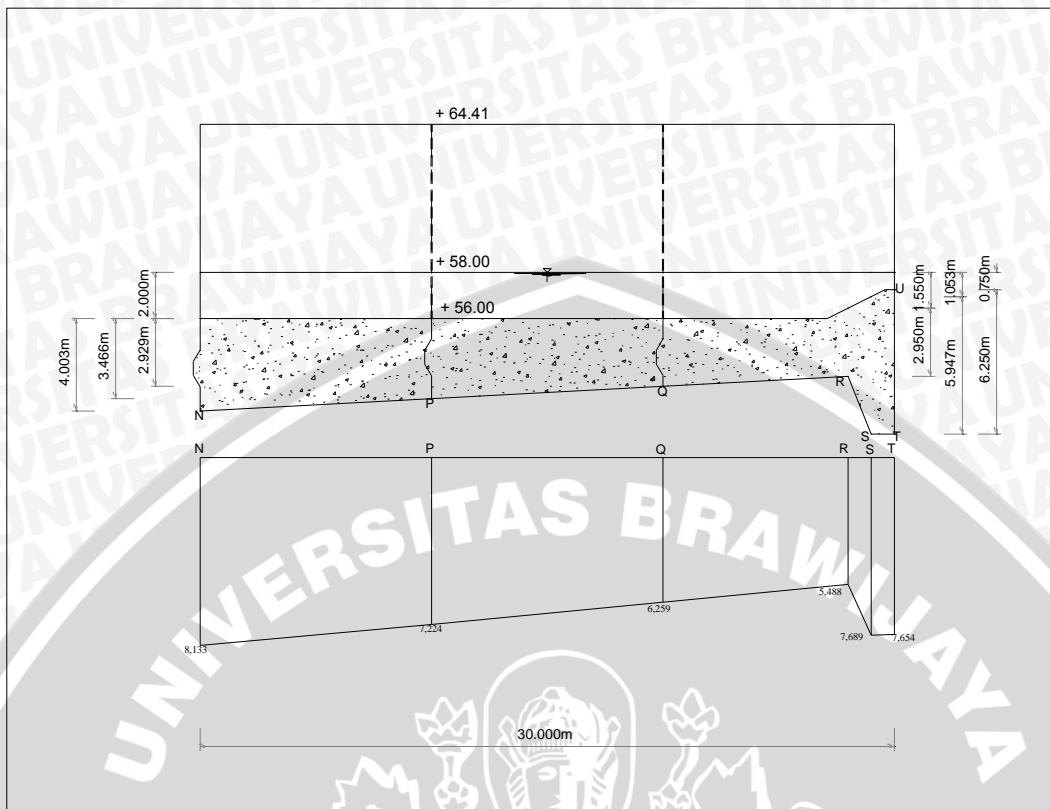

**Gambar 4.36. Tebal Lantai pada Kondisi Muka Air Normal**

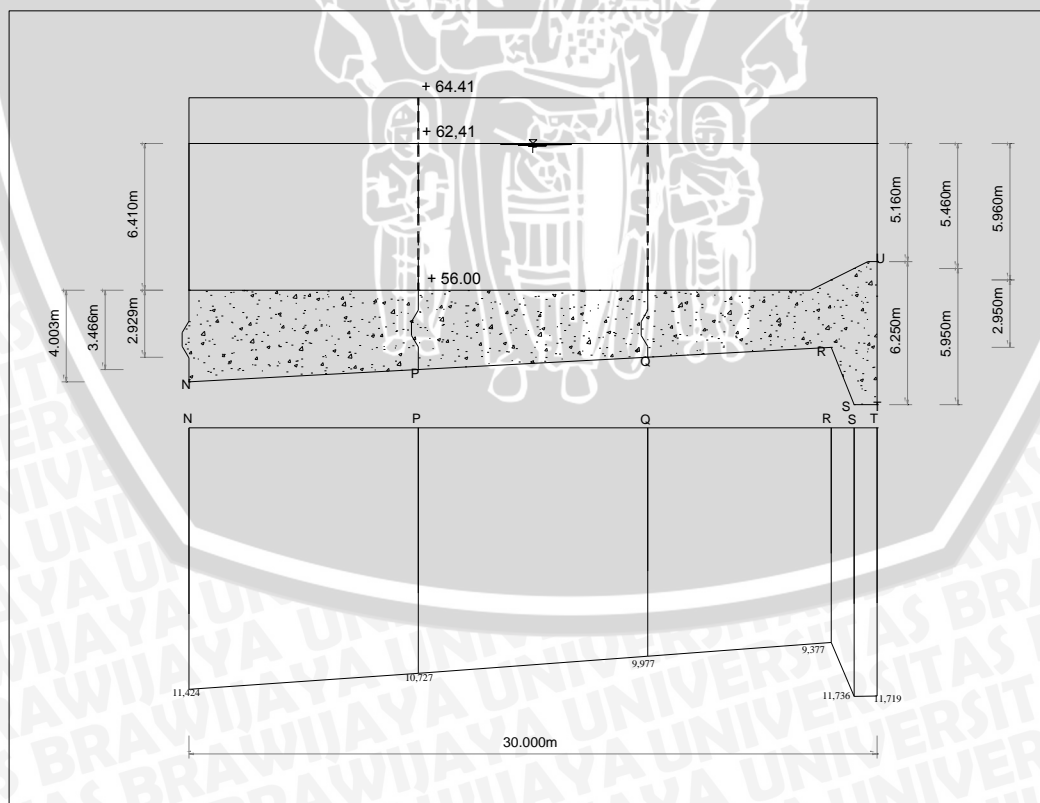

**Gambar 4.37. Tebal Lantai pada Kondisi Muka Air Banjir**

Tabel 4.43. Perhitungan Keamanan Tebal Lantai Kondisi Muka Air Normal

No.	Titik	Px	Wx	$\gamma$	S = 1,5	S	$\frac{Px - Wx}{\gamma}$	dx	Kontrol Keamanan Tebal Lantai
		(ton/m <sup>2</sup> )	(m)	(ton/m <sup>3</sup> )			(ton/m <sup>2</sup> )		
		[1]	[2]	[3]		[4]	[5]	[6]	
1	O	8,133	2,000	2,400	1,500		3,833	4,003	Aman
2	Q	7,224	2,000	2,400	1,500		3,265	3,466	Aman
3	R	6,259	2,000	2,400	1,500		2,662	2,929	Aman
4	S	5,488	1,550	2,400	1,500		2,461	2,950	Aman
5	T	7,689	1,050	2,400	1,500		4,150	5,950	Aman
6	U	7,654	0,750	2,400	1,500		4,315	6,250	Aman

Sumber: Hasil Perhitungan

Keterangan:

- [ 1 ] = Uplift yang timbul pada titik x (ton/m<sup>2</sup>)  
 [ 2 ] = Kedalaman air pada titik x (m)  
 [ 3 ] = Berat jenis bahan (ton/m<sup>3</sup>)  
 = 2,400 ton/m<sup>3</sup>  
 [ 4 ] = Faktor keamanan  
 = 1,5 (Normal)  
 [ 5 ] = [ 4 ](( [ 1 ] - [ 2 ] ) / [ 3 ] )  
 [ 6 ] = Tebal lantai pada titik x (ton/m<sup>2</sup>)  
 [ 7 ] = [ 6 ] ≥ [ 5 ] (Aman)



Tabel 4.44. Perhitungan Keamanan Tebal Lantai Kondisi Muka Air Banjir

No.	Titik	Px	Wx	$\gamma$	S = 1,25	S	$\frac{Px - Wx}{\gamma}$	dx	Kontrol Keamanan Tebal Lantai
		(ton/m <sup>2</sup> )	(m)	(ton/m <sup>3</sup> )			(ton/m <sup>2</sup> )		
		[1]	[2]	[3]			[4]	[5]	
1	O	11,424	6,410	2,400	1,250	2,611	4,003	Aman	
2	Q	10,727	6,410	2,400	1,250	2,248	3,466	Aman	
3	R	9,977	6,410	2,400	1,250	1,858	2,929	Aman	
4	S	9,377	5,960	2,400	1,250	1,780	2,950	Aman	
5	T	11,736	5,460	2,400	1,250	3,269	5,950	Aman	
6	U	11,719	5,160	2,400	1,250	3,416	6,250	Aman	

Sumber: Hasil Perhitungan

Keterangan:

- [ 1 ] = Uplift yang timbul pada titik x (ton/m<sup>2</sup>)  
 [ 2 ] = Kedalaman air pada titik x (m)  
 [ 3 ] = Berat jenis bahan (ton/m<sup>3</sup>)  
 = 2,400 ton/m<sup>3</sup>  
 [ 4 ] = Faktor keamanan  
 = 1,25 (Normal)  
 [ 5 ] = [ 4 ](( [ 1 ] - [ 2 ] ) / [ 3 ] )  
 [ 6 ] = Tebal lantai pada titik x (ton/m<sup>2</sup>)  
 [ 7 ] = [ 6 ] ≥ [ 5 ] (Aman)

#### 4.4. Perencanaan Pondasi Tiang

Dalam analisis stabilitas bendung gerak, bangunan penguras dan dinding penahan sebelumnya didapatkan hasil yang menunjukkan bahwa kemampuan tanah tidak mencukupi untuk menopang bangunan di atasnya. Hal ini dapat dilihat pada perhitungan sebelumnya yang menyatakan bahwa tegangan izin tanah tidak dapat memenuhi tegangan yang terjadi pada bangunan.

Dengan memperhatikan keadaan tanah maka digunakan kelompok tiang yang berupa pondasi tiang pancang sebagai alternatif dalam mengatasi permasalahan kemampuan tanah yang ada.

##### 4.4.1. Desain Pondasi Tiang Pada Bendung Gerak (*Barrage*)

Elevasi dasar pondasi bangunan terletak pada elevasi 54,00 m pada kedalaman 10,50 m dari titik pengeboran awal dengan nilai SPT 31. Adapun spesifikasi tiang adalah sebagai berikut:

$$\begin{aligned} \text{diamater (d)} &= 0,4 \text{ meter} \\ f'c &= 20 \text{ MPa} = 200 \text{ kg/cm}^2 \\ \text{kedalaman tiang (D)} &= 6 \text{ meter (El. +48,00 m)} \\ \text{nilai SPT pada kedalaman tersebut} &= 50 \\ A_{\text{tiang}} &= d^2 \\ &= 0,4^2 \\ &= 0,16 \text{ m}^2 \\ &= 1600 \text{ cm}^2 \\ \text{jarak antar pusat tiang (s)} &= 2,5 \text{ meter} \end{aligned}$$

Persyaratan:

$$\begin{aligned} \text{jarak tiap tiang} &= S \geq 2,5 d \\ &= 2,5 \text{ m} \geq 1,00 \text{ m ( memenuhi syarat)} \end{aligned}$$

##### 4.4.1.1. Analisis Daya Dukung Tiang

###### 4.4.1.1.1. Analisis Terhadap Kekuatan Bahan Tiang

Analisis daya dukung tiang dapat dianalisis dari berbagai cara. Kemampuan tiang dapat dianalisis dengan mempertimbangkan kekuatan bahan tiang. Untuk mengetahui kekuatan yang diizinkan pada tiang maka perlu mengetahui tegangan tekan pada bahan tiang dan luas penampang tiang. Adapun perhitungan kekuatan bahan tiang sebagai berikut:

$$\begin{aligned} \sigma_{\text{bahan}} &= 0,45 \times f'c \\ &= 0,45 \times 200 \text{ kg/cm}^2 \\ &= 90 \text{ kg/cm}^2 \end{aligned}$$

$$\begin{aligned}
 A_{\text{tiang}} &= d^2 \\
 &= 0,40^2 \\
 &= 0,16 \text{ m}^2 \\
 &= 1600 \text{ cm}^2 \\
 P_{\text{tiang}} &= \sigma_{\text{bahan}} \times A_{\text{tiang}} \\
 &= 90 \times 1600 \\
 &= 144000 \text{ kg} \\
 &= 144,00 \text{ ton}
 \end{aligned}$$

#### 4.4.1.1.2. Perhitungan Pembagian Tekanan pada Kelompok Tiang

Beban yang bekerja pada pondasi perlu dianalisis yaitu mengenai pembagian tekanan yang terjadi pada kelompok tiang. Hal ini dilakukan untuk mengetahui kemampuan dari kelompok tiang yang telah didesain dapat menanggung beban yang berada di atasnya. Beban normal yang diterima oleh tiang merupakan beban eksentris sehingga dianalisis menggunakan beban sentris yaitu ditambahkan dengan momen. Beban maksimum yang diterima oleh tiap tiang pada kelompok tiang dapat dihitung.

Analisis digunakan pada bendung gerak pada kondisi muka air normal pada keadaan gempa sebagai berikut:

Tegangan tanah yang terjadi :

$$\sigma_{\text{maks}} = 16,36 \text{ ton/m}^2$$

$$\sigma_{\text{min}} = 9,42 \text{ ton/m}^2$$

Daya dukung tanah pondasi  $\sigma_{\text{izin}} = 12,33 \text{ ton/m}^2$

$$\begin{aligned}
 \text{Kekurangan daya dukung} &= \sigma_{\text{maks}} - \sigma_{\text{izin}} \\
 &= 16,36 \text{ ton/m}^2 - 12,33 \text{ ton/m}^2 \\
 &= 4,04 \text{ ton/m}^2
 \end{aligned}$$

$$\begin{aligned}
 \text{Luas telapak pondasi} &= B \times L \\
 &= 21,60 \text{ m} \times 15,00 \text{ m} \\
 &= 324,00 \text{ m}^2
 \end{aligned}$$

Beban vertikal yang perlu dipikul tiang minimal

$$\begin{aligned}
 &= \text{Luas telapak pondasi} \times \text{Kekurangan daya dukung} \\
 &= 324,00 \text{ m}^2 \times 4,04 \text{ ton/m}^2 \\
 &= 1308,50 \text{ ton}
 \end{aligned}$$

$$\begin{aligned}\text{Proporsi terhadap beban total} &= \frac{1308,50}{4177,317} \\ &= 31,324 \%\end{aligned}$$

$$\begin{aligned}\text{Beban horizontal yang perlu dipikul tiang minimal} &= 31,324 \% \times 1925,08 \text{ ton} \\ &= 577,09 \text{ ton}\end{aligned}$$

$$\Sigma V = 1308,505 \text{ ton (15 meter panjang)}$$

$$e = 0,97$$

$$\begin{aligned}M_y &= \Sigma V \times e \\ &= 1308,505 \times 0,97 \\ &= 1268,459 \text{ ton.m}\end{aligned}$$

$$n = 48 \text{ buah}$$

$$n_y = 6 \text{ buah}$$

$$n_x = 8 \text{ buah}$$

$$X_{\max} = 8,75 \text{ m}$$

$$Y_{\max} = 6,25 \text{ m}$$

Jumlah kuadrat absis-absis tiang pancang:

$$\begin{aligned}\Sigma X^2 &= 6.2.(8,75)^2 + 6.2.(6,25)^2 + 6.2.(3,75)^2 + 6.2.(1,25)^2 \\ &= 1575,15 \text{ m}^2\end{aligned}$$

$$\begin{aligned}\Sigma Y^2 &= 8.2.(6,25)^2 + 8.2.(3,75)^2 + 8.2.(1,25)^2 \\ &= 875,00 \text{ m}^2\end{aligned}$$

Beban yang diterima tiap tiang maksimum adalah:

$$\begin{aligned}P_{\max} &= \frac{\Sigma V}{n} + \frac{M_y \cdot X_{\max}}{n_y \cdot \Sigma X^2} + \frac{M_x \cdot Y_{\max}}{n_x \cdot \Sigma Y^2} \\ &= \frac{1303,587}{48} + \frac{1268,459 \cdot 8,75}{6 \cdot 1575,15} + \frac{1268,459 \cdot 6,25}{8 \cdot 875,00} \\ &= 30,020 \text{ ton}\end{aligned}$$

Syarat,  $P_{\max} < P_{\text{tiang}} = 30,020 < 144,0 \text{ ton} \dots\dots\dots \text{OK}$

Beban yang diterima oleh tiap tiang terdapat pada Tabel 4.45 adalah sebagai berikut:

**Tabel 4.45. Pembagian Tekanan Pada Kelompok Tiang**

Tiang	Jarak	a	b	c	d	e	f	g	h
1	6,25	27,219	27,554	27,890	28,225	28,561	28,896	29,232	29,567
2	3,75	26,766	27,101	27,437	27,772	28,108	28,443	28,779	29,114
3	1,25	26,313	26,648	26,984	27,319	27,655	27,990	28,326	28,661
4	-1,25	25,860	26,195	26,531	26,866	27,202	27,537	27,873	28,208
5	-3,75	25,407	25,742	26,078	26,413	26,749	27,084	27,420	27,755
6	-6,25	24,954	25,289	25,625	25,960	26,296	26,631	26,967	27,302

Sumber: Hasil Perhitungan

Contoh Perhitungan:

$$\begin{aligned}
 P_{1a} \quad (x_i = -8,75)(y_i = 6,25) &= \frac{\Sigma V}{n} + \frac{M_y \cdot x_1}{n_y \cdot \Sigma X^2} + \frac{M_x \cdot y_1}{n_y \cdot \Sigma Y^2} \\
 &= \frac{1308,505}{48} + \frac{1268,459 \cdot -8,75}{6 \cdot 1575,15} + \frac{1268,459 \cdot 6,25}{8 \cdot 875,00} \\
 &= 27,219 \text{ ton}
 \end{aligned}$$

Karena, beban maksimum yang diterima tiang lebih kecil dari kemampuan tiang maka desain tersebut memenuhi persyaratan.



**4.4.1.1.3. Daya Dukung Vertikal**

Daya dukung tiang tanah pondasi umumnya diperoleh dari jumlah daya dukung terpusat tiang dan tahanan geser pada dinding tiang. Besarnya daya dukung yang diizinkan diperoleh dari persamaan sebagai berikut:

$$R_a = \frac{1}{n} (R_p + R_f)$$

a. Daya dukung terpusat tiang ( $R_p$ )

- Panjang penetrasi ekivalen pada lapisan pendukung

1. Harga  $N$  rata-rata untuk perencanaan tanah pondasi pada ujung tanah

didapatkan dengan persamaan sebagai berikut:  $\bar{N} = \frac{N_1 + \bar{N}_2}{2}$

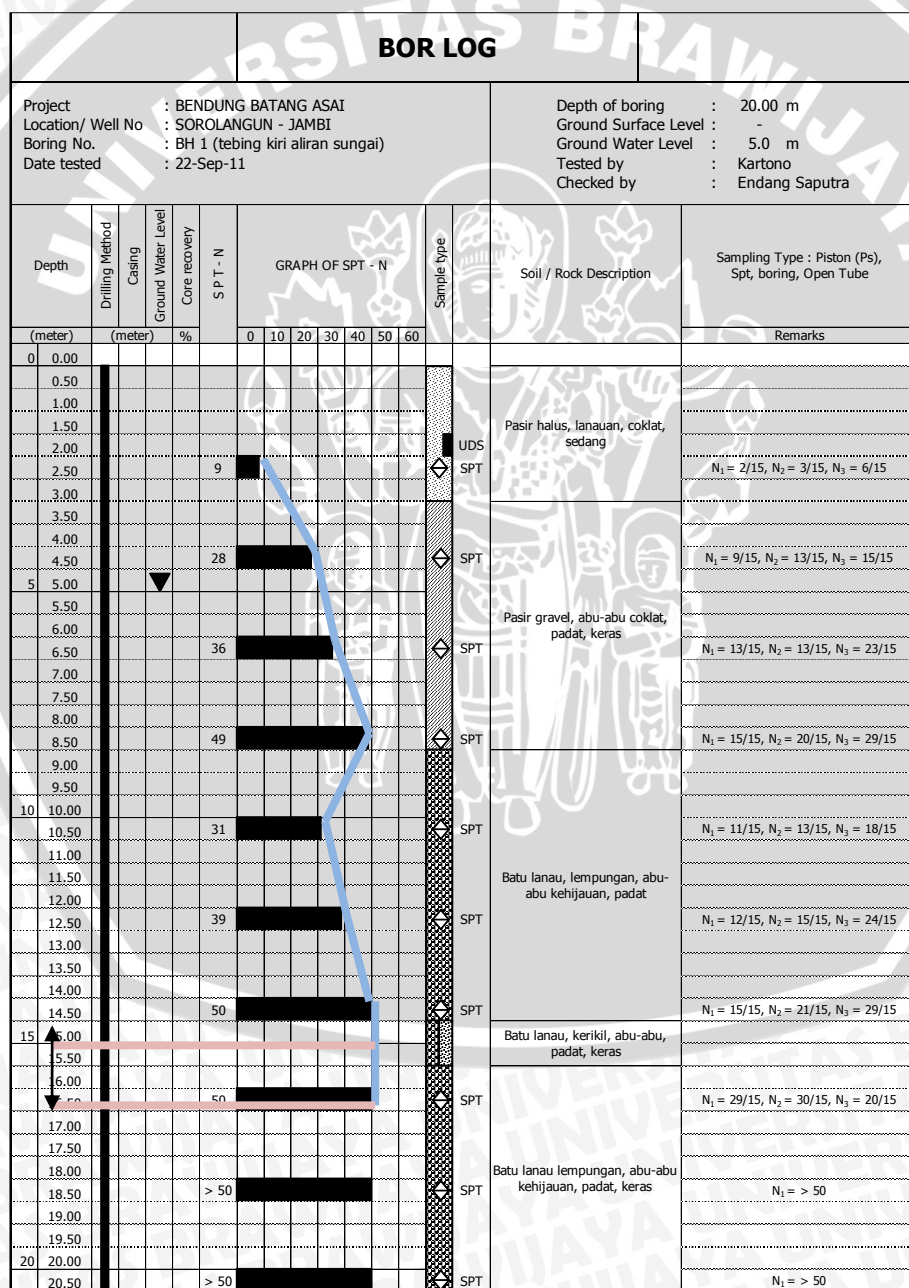

Gambar 4.38. Kalibrasi Harga N

Dari Gambar 4.38. menunjukkan bahwa:

Harga N SPT pada ujung tiang ( $N_1$ ) = 50

Harga N SPT rata-rata pada jarak 4 D dari ujung tiang ( $\bar{N}_2$ ):

$$\begin{aligned}\bar{N}_2 &= \frac{50+50}{2} \\ &= 50\end{aligned}$$

Sehingga, harga N SPT rerata untuk perencanaan tanah pondasi pada ujung tiang adalah:

$$\bar{N} = \frac{50+50}{2} = 50$$

2. Menentukan panjang ekivalensi penetrasi.

Harga nilai N SPT yang telah dirata-rata diletakkan pada tabel *Bor Log*. Titik tersebut dengan titik N SPT akan membentuk segitiga dengan luasan tertentu apabila N SPT yang ada berbeda-beda, namun apabila nilai N SPT sama maka nilai panjang ekivalensi penetrasi sama dengan 4D. Sehingga didapatkan panjang penetrasi sepanjang 1,4 meter. Seperti yang terlihat pada Gambar 4.38.

• Daya dukung pada ujung tiang

1. Diagram perhitungan dari intensitas daya dukung ultimate tanah pondasi pada ujung tiang dapat dilihat pada Gambar 2.4.

$$\frac{1}{D} = \frac{1,60}{0,40} = 4,00$$

Didapatkan nilai  $q_d/N = 18$

2. Daya dukung terpusat tiang:

$$\begin{aligned}q_d &= 18 \times 50 \\ &= 900 \text{ ton/m}^2\end{aligned}$$

$$\begin{aligned}R_p &= q_d \times d^2 \\ &= 144,00 \text{ ton}\end{aligned}$$

b. Gaya geser dinding tiang ( $R_f$ )

Gaya geser dinding tiang dapat dihitung dengan memperhatikan nilai N SPT pada lapisan tanah dengan melihat tabel *Bor Log* dan intensitas gaya geser dinding tiang dengan melihat Tabel 2.3.

Pada tabel *Bor Log*, lapisan tanah pada tiang berupa batu pasir. Intensitas gaya geser pada tanah pasir adalah:

$$F_i = \frac{N}{5} = \frac{50}{5} = 10$$

$$\text{tebal lapisan (li)} = 2 \text{ meter}$$

$$\text{Panjang keliling tiang (U)} = 4.d = 1,6 \text{ m}$$

Gaya geser dinding tiang:

$$\begin{aligned} R_f &= U \cdot f_i \cdot li \\ &= 1,6 \cdot 10 \cdot 2 \\ &= 32,00 \text{ ton} \end{aligned}$$

#### c. Daya Dukung Ulimit

Daya dukung ulimit memperhatikan daya dukung pada ujung tiang dan gaya geser maksimum dinding tiang. Perhitungan daya dukung ultimate sebagai berikut:

$$\begin{aligned} R_u &= R_p + R_f \\ &= 144,00 + 32,00 \\ &= 176,00 \text{ ton} \end{aligned}$$

#### d. Daya Dukung yang Diizinkan

Kondisi normal:

$$R_a = \frac{R_u}{3} = \frac{176,00}{3} = 58,67 \text{ ton}$$

Kondisi gempa:

$$R_a = \frac{R_u}{2} = \frac{176,00}{2} = 88,00 \text{ ton}$$

#### 4.4.1.2. Gaya tarik (*Pull Out Force*)

Gaya tarik tiang yang diizinkan adalah suatu harga yang diperoleh dengan membagi gaya tarik maksimum sebuah tiang dengan suatu faktor keamanan. Gaya tarik yang diizinkan ini dibatasi oleh gaya penahan tarikan dari tanah pondasi dan tegangan pada tubuh tiang (tegangan tarik/*tensile stress*). Gaya tarik yang terjadi dapat dihitung menggunakan persamaan (2-32) sebagai berikut:

$$\begin{aligned} Q_u (\text{tarik}) &= \Sigma f_s \cdot A_s + W_p \\ &= 2/3 \cdot f_s \cdot \text{tekan} \cdot d \cdot H + \rho \cdot V \cdot g \\ &= 2/3 \cdot 0,7 \cdot 40 \cdot 600 + 0,0024 \cdot 40^2 \cdot 600 \cdot 10 \\ &= 34240 \text{ kg} \\ &= 34,24 \text{ ton} \end{aligned}$$

#### 4.4.1.3. Daya Dukung Mendatar

Untuk mengamati gaya penahan mendatar pada tiang dipakai suatu cara untuk menentukan daya dukung yang diizinkan berdasarkan tegangan di dalam tubuh tiang dan besarnya pergeseran pada kepala tiang. Pada cara ini tiang dihitung sebagai suatu gelagar di atas pondasi yang elastis yang dinyatakan dengan tegangan pada tubuh tiang



besarnya pergeseran pada kepala tiang dan koefisien reaksi lapisan tanah di bawahnya, dalam arah yang tegak lurus dengannya. Daya dukung mendatar yang diizinkan untuk 1 tiang yaitu sebagai berikut:

$$k = 34,51 \text{ kg/cm}^2$$

$$E = 4700\sqrt{fc'} \\ = 210190,38 \text{ kg/cm}^2$$

$$I = 1/12 \cdot b \cdot h^3 \\ = 1/12 \cdot 40 \cdot 40^3 \\ = 213333,33 \text{ cm}^4$$

$$\beta = \sqrt[4]{\frac{k \cdot D}{4 \cdot EI}} = 0,009366 \text{ cm}^{-1} = 0,937 \text{ m}^{-1}$$

Anggapan pergeseran normal:  $\delta = 0,1 \text{ cm}$

Kondisi Normal:

$$H_a = \frac{k \cdot B}{\beta} \cdot \delta a \\ = \frac{34,51 \cdot 40}{0,937} \cdot 0,1 \\ = 14739,45 \text{ kg} = 15 \text{ ton}$$

Kondisi gempa:

$$H_a = \frac{k \cdot B}{\beta} \cdot \delta a \\ = \frac{34,51 \cdot 40}{0,937} \cdot 0,15 \\ = 22109,18 \text{ kg} = 22 \text{ ton}$$

#### 4.4.1.3.1. Konstanta Pegas $K_v$ untuk Arak Vertikal dan Koefisien $k$ dari Reaksi Lapisan di Bawah Permukaan Tanah dalam Arah Mendatar

a. Perkiraan konstanta pegas  $K_v$  dalam arah vertikal

Perhitungan secara praktis untuk memperkirakan nilai  $K_v$  dengan memakai konstanta tanah atau secara empiris dengan memakai cara statistik berdasarkan data dari percobaan pembebanan.

$$K_v = a \cdot \frac{A_p + E_p}{l}$$

$$\text{Modulus elastisitas tiang (Ep)} = 210190,39 \text{ kg/cm}^2$$

untuk tiang pratekan (*prestressed concrete*)

$$a = 0,041 \cdot (l/D) - 0,27 \\ = 0,041 \cdot (600/40) - 0,27 \\ = 0,345$$

sehingga, nilai  $K_v$  sebagai berikut:

$$\begin{aligned} K_v &= 0,345 \cdot \frac{1600,00 \times 210190,39}{600} \\ &= 193375,2 \text{ kg/cm} \\ &= 193,38 \text{ ton/cm} \end{aligned}$$

b. Perkiraan koefisien  $k$  dari reaksi tanah di bawah permukaan dalam arah mendatar

koefisien reaksi tanah di bawah permukaan dalam arah mendatar, diperkirakan berdasarkan persamaan berikut:

$$\begin{aligned} k_o &= 0,2 \cdot E_o \cdot D^{-3/4} \\ &= 0,2 \cdot 28N \cdot 600 \cdot 40^{-3/4} \\ &= 0,2 \cdot 28 \cdot 31 \cdot 600 \cdot 40^{-3/4} \\ &= 10,915 \text{ kg/cm}^3 \\ k &= k_o \cdot y^{-1/2} \\ &= 10,914 \cdot (0,1)^{-1/2} \\ &= 34,515 \text{ kg/cm}^3 \end{aligned}$$

#### 4.4.1.3.2. Reaksi Tiang dan Pergeseran pada Tumpuan

Setelah daya tiang yang diizinkan diperoleh, kemudian dihitung banyaknya tiang yang diperlukan dan pembagian beban ke kepala tiang. Perhitungan reaksi pada kepala tiang dilakukan dengan memperkirakan banyaknya tiang dan susunan tiang. Bila reaksi yang diperoleh ternyata melebihi daya dukung yang diizinkan atau melebihi pergeseran yang diizinkan, maka perkiraan di atas harus diperiksa kembali sehingga reaksi yang diperoleh terletak di dalam batas harga yang diizinkan. Gambar dari susunan kelompok tiang dapat dilihat pada Gambar 4.39.

Pada pondasi tiang bekerja gaya vertikal  $V_o$ , gaya mendatar  $H_o$  dan momen putar  $M_o$ , dan gaya-gaya luar ini berada dalam keadaan setimbang dengan gaya-gaya yang menyebabkan perpindahan pada tumpuan yang kaku, misalnya perpindahan mendatar  $\delta_x$  pada pusat gabungan tiang, perpindahan dalam arah vertikal  $\delta_y$ , perpindahan tempat dengan cara berputar (*rotary displacement*)  $\alpha$  dengan anggapan sebagai pegas yang elastis.

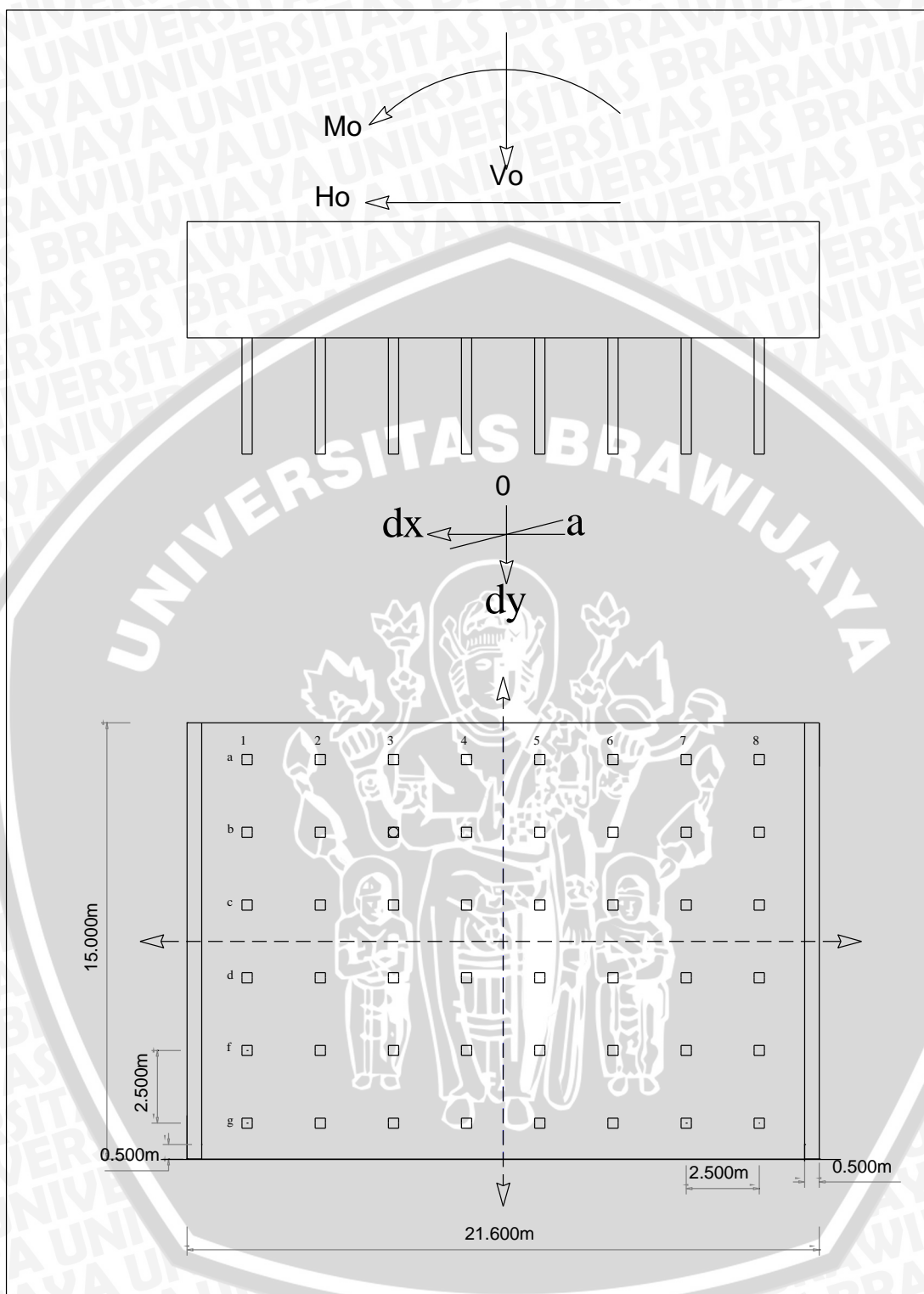

Gambar 4.39. Desain Kelompok Tiang Bendung Gerak (*Barrage*)

#### 4.4.1.3.3. Kondisi Normal

##### a. Gaya Luar pada bangunan

$$\begin{aligned} \text{Beban vertikal (Vo)} &= 830,45 \text{ ton} \\ \text{Beban mendatar (Ho)} &= 177,87 \text{ ton} \\ \text{Momen (Mo)} &= 466,69 \text{ ton.m} \end{aligned}$$

##### b. Daya dukung yang diizinkan

- Daya dukung kekuatan pemancangan yang diizinkan untuk 1 tiang (arah axial)

$$R_a = 58,67 \text{ ton}$$

- Konstanta pegas dalam arah axial untuk tiang

$$\begin{aligned} K_v &= 193375,2 \text{ kg/cm} \\ &= 193,38 \text{ ton/cm} \end{aligned}$$

- Kekuatan tarik (pull out force) yang diizinkan untuk 1 tiang

$$P_a = 34,24 \text{ ton}$$

- Daya dukung mendatar yang diizinkan untuk 1 tiang

$$H_a = 14739,45 \text{ kg} = 15 \text{ ton}$$

##### c. Reaksi pada kepala tiang dengan cara perpindahan (*displacement*)

- Konstanta pegas pada tiang dalam arah sejajar sumbu tiang

$$\begin{aligned} K_1 &= 4.EI.\beta^3 \\ &= 14739 \text{ ton/m} \end{aligned}$$

$$\begin{aligned} K_2 &= 2.EI.\beta^2 \\ &= 7868 \text{ ton/rad} \end{aligned}$$

$$\begin{aligned} K_3 &= 2.EI.\beta^2 \\ &= 7868 \text{ ton/rad} \end{aligned}$$

$$\begin{aligned} K_4 &= 2.EI.\beta \\ &= 8400 \text{ tm/rad} \end{aligned}$$

- Koefisien-koefisien

Karena tidak ada sudut yang dibentuk oleh tiang ke  $i$  dengan sumbu vertikal maka  $\theta_i = 0^\circ$

$$\begin{aligned} A_{xx} &= \Sigma(K_1 \cdot \cos^2 \theta_i + K_v \cdot \sin^2 \theta_i) \\ &= 707494 \end{aligned}$$

$$\begin{aligned} A_{xy} &= A_{yx} = \Sigma((K_v + K_i) \cdot \sin \theta_i \cdot \cos \theta_i) \\ &= 0 \end{aligned}$$

$$\begin{aligned} A_{x\alpha} &= \Sigma((Kv - Ki).xi.\sin \theta_i.\cos \theta_i - K2.\cos \theta_i) \\ &= -377667 \end{aligned}$$

$$\begin{aligned} A_{yy} &= \Sigma(Kv.\cos^2 \theta_i + K_1.\sin^2 \theta_i) \\ &= 928200,76 \end{aligned}$$

$$\begin{aligned} A_{y\alpha} = A_{\alpha y} &= \Sigma((Kv.\cos^2 \theta_i + K_1.\sin^2 \theta_i)xi + K_2.\sin \theta_i) \\ &= 0 \end{aligned}$$

$$\begin{aligned} A_{\alpha\alpha} &= \Sigma((Kv.\cos^2 \theta_i + K_1.\sin^2 \theta_i)xi^2 + (K_2 + K_3)xi.\sin \theta_i + K_4) \\ &= 30859793 \end{aligned}$$

- Pergeseran pada pusat tumpuan

Koefisien yang telah dihitung digunakan untuk menyelesaikan persamaan sehingga didapatkan nilai pergeseran pada pusat tumpuan. Persamaan tersebut adalah:

$$A_{xx} \cdot \delta x + A_{xy} \cdot \delta y + A_{x\alpha} \cdot \alpha = H_0$$

$$A_{yx} \cdot \delta x + A_{yy} \cdot \delta y + A_{y\alpha} \cdot \alpha = V_0$$

$$A_{\alpha x} \cdot \delta x + A_{\alpha y} \cdot \delta y + A_{\alpha\alpha} \cdot \alpha = M_0$$

$$\begin{bmatrix} A_{xx} & A_{yx} & A_{x\alpha} \\ A_{xy} & A_{yy} & A_{y\alpha} \\ A_{\alpha x} & A_{\alpha y} & A_{\alpha\alpha} \end{bmatrix} * \begin{bmatrix} \delta x \\ \delta y \\ \alpha \end{bmatrix} = \begin{bmatrix} H_0 \\ V_0 \\ M_0 \end{bmatrix}$$

$$\begin{bmatrix} 707493,85 & 0 & -377667,30 \\ 0 & 928200,8 & 0 \\ -377667,30 & 0 & 30859792,67 \end{bmatrix} * \begin{bmatrix} \delta x \\ \delta y \\ \alpha \end{bmatrix} = \begin{bmatrix} 177,874 \\ 830,445 \\ 466,787 \end{bmatrix}$$

$$\begin{bmatrix} 0,0000014 & 0 & 0,000000017 \\ 0 & 0,0000011 & 0 \\ 0,0000000174 & 0 & 0,000000033 \end{bmatrix} * \begin{bmatrix} 177,874 \\ 830,445 \\ 466,787 \end{bmatrix} = \begin{bmatrix} \delta x \\ \delta y \\ \alpha \end{bmatrix}$$

Dengan perhitungan di atas didapat pergeseran pada setiap tiang sebagai berikut:

$$\delta x = 0,00026 \text{ cm}$$

$$\delta y = 0,00089 \text{ cm}$$

$$\alpha = 0,00002 \text{ rad}$$

- d. Pergeseran pada setiap kepala tiang

$$\text{Karena, } \delta'x_i = \delta x.\cos \theta_i - (\delta y + \alpha.xi)\sin \theta_i$$

$$\text{Tiang 1- 8, } x_i = 0, \text{ sehingga } \delta'x_i = 0,00026 \text{ cm}$$

$$\text{Karena, } \delta'y_i = \delta x.\sin \theta_i + (\delta y + \alpha.xi)\cos \theta_i$$

- Tiang 1,  $x_i = 8,75$  maka  $\delta'y_i = 0,00106$  cm
- Tiang 2,  $x_i = 6,25$  maka  $\delta'y_i = 0,00101$  cm
- Tiang 3,  $x_i = 3,75$  maka  $\delta'y_i = 0,00096$  cm
- Tiang 4,  $x_i = 1,25$  maka  $\delta'y_i = 0,00092$  cm
- Tiang 5,  $x_i = -1,25$  maka  $\delta'y_i = 0,00087$  cm
- Tiang 6,  $x_i = -3,75$  maka  $\delta'y_i = 0,00083$  cm
- Tiang 7,  $x_i = -6,25$  maka  $\delta'y_i = 0,00078$  cm
- Tiang 8,  $x_i = -8,75$  maka  $\delta'y_i = 0,00073$  cm

e. Gaya axial pada setiap tiang

- Karena,  $P_{Ni} = K_v \cdot \delta'y_i$
- Tiang 1,  $P_{Ni} = 20,401 < Ra = 58,67$  ton
- Tiang 2,  $P_{Ni} = 19,515$
- Tiang 3,  $P_{Ni} = 18,630$
- Tiang 4,  $P_{Ni} = 17,744$
- Tiang 5,  $P_{Ni} = 16,858$
- Tiang 6,  $P_{Ni} = 16,972$
- Tiang 7,  $P_{Ni} = 15,086$
- Tiang 8,  $P_{Ni} = 14,201 > Pa = -34,24$  ton

f. Gaya dalam Arah Sumbu orthogonal untuk setiap tiang

- Karena,  $P_{Hi} = K_1 \cdot \delta'x_i - K_2 \cdot \alpha$
- Tiang 1-8,  $P_{Hi} = 3,706$  ton
- Syarat,  $P_{Hi} = 3,706$  ton  $< Ha = 15$  ton

g. Momen pada kepala tiang

- Karena,  $M_{ti} = -K_3 \cdot \delta'x_i + K_4 \cdot \alpha$
- Tiang 1-8,  $M_{ti} = -1,901$  ton.m

h. Pemeriksaan arah axial

- $\Sigma H_i = P_{Hi} \times \text{jml tiang}$
- $= 3,706 \times 48$
- $= 177,874$  ton
- Syarat,  $\Sigma H_i = H_o = 177,874$  ton .....OK.....!!!!

$$\Sigma V_i = P_{Ni} \times \text{jml tiang}$$

Tiang 1,	$P_{Ni}$	= 20,401	x 6	= 122,407
Tiang 2,	$P_{Ni}$	= 19,515	x 6	= 117,092
Tiang 3,	$P_{Ni}$	= 18,630	x 6	= 111,778
Tiang 4,	$P_{Ni}$	= 17,744	x 6	= 106,463
Tiang 5,	$P_{Ni}$	= 16,858	x 6	= 101,148
Tiang 6,	$P_{Ni}$	= 16,972	x 6	= 95,834
Tiang 7,	$P_{Ni}$	= 15,086	x 6	= 90,519
Tiang 8,	$P_{Ni}$	= 14,201	x 6	= <u>85,204</u> +
	Jumlah			= 830,445 ton

$$\text{Syarat, } \Sigma V_i = V_o = 830,445 \text{ ton .....OK...!!!!}$$

$$\Sigma M_i = (M_{ti} + V_i \cdot x_i) \cdot \text{jml tiang}$$

Tiang 1,	$-1,901 + (20,401 \times 8,75) \times 6$	= 1059,66
Tiang 2,	$-1,901 + (19,515 \times 6,25) \times 6$	= 720,42
Tiang 3,	$-1,901 + (18,630 \times 3,75) \times 6$	= 407,76
Tiang 4,	$-1,901 + (17,744 \times 1,25) \times 6$	= 121,67
Tiang 5,	$-1,901 + (16,858 \times -1,25) \times 6$	= -137,84
Tiang 6,	$-1,901 + (16,972 \times -3,75) \times 6$	= -370,78
Tiang 7,	$-1,901 + (15,086 \times -6,25) \times 6$	= -577,15
Tiang 8,	$-1,901 + (14,201 \times -8,75) \times 6$	= <u>-756,94</u> +
	Jumlah	= 466,79 ton.m

$$\text{Syarat, } \Sigma M_i = M_o = 466,79 \text{ ton.m .....OK...!!!!}$$

#### 4.4.1.3.4. Kondisi Gempa

##### a. Gaya Luar pada bangunan

$$\text{Beban vertikal (} V_o \text{)} = 1308,50 \text{ ton}$$

$$\text{Beban mendatar (} H_o \text{)} = 577,09 \text{ ton}$$

$$\text{Momen (} M_o \text{)} = 1268,46 \text{ ton.m}$$

##### b. Daya dukung yang diizinkan

- Daya dukung kekuatan pemancangan yang diizinkan untuk 1 tiang (arah axial)

$$R_a = 88,00 \text{ ton}$$

- Konstanta pegas dalam arah axial untuk tiang  
 $K_v = 193375 \text{ kg/cm} = 193,38 \text{ ton/cm}$
- Kekuatan tarik (pull out force) yang diizinkan untuk 1 tiang  
 $P_a = 34,24 \text{ ton}$
- Daya dukung mendatar yang diizinkan untuk 1 tiang  
 $H_a = 22109,18 \text{ kg} = 22 \text{ ton}$

c. Reaksi pada kepala tiang dengan cara perpindahan (*displacement*)

- Konstanta pegas pada tiang dalam arah sejajar sumbu tiang

$$K_1 = 4.EI.\beta^3$$

$$= 14739 \text{ ton/m}$$

$$K_2 = 2.EI.\beta^2$$

$$= 7868 \text{ ton/rad}$$

$$K_3 = 2.EI.\beta^2$$

$$= 7868 \text{ ton/rad}$$

$$K_4 = 2.EI.\beta$$

$$= 8400 \text{ tm/rad}$$

- Koefisien-koefisien

Karena tidak ada sudut yang dibentuk oleh tiang ke  $i$  dengan sumbu vertikal maka  $\theta_i = 0^\circ$

$$A_{xx} = \Sigma(K_1.\cos^2 \theta_i + K_v.\sin^2 \theta_i)$$

$$= 707494$$

$$A_{xy} = A_{yx} = \Sigma((K_v + K_i).\sin \theta_i.\cos \theta_i)$$

$$= 0$$

$$A_{x\alpha} = \Sigma((K_v - K_i).x_i.\sin \theta_i.\cos \theta_i - K_2.\cos \theta_i)$$

$$= -377667$$

$$A_{yy} = \Sigma(K_v.\cos^2 \theta_i + K_1.\sin^2 \theta_i)$$

$$= 928200,76$$

$$A_{y\alpha} = A_{\alpha y} = \Sigma((K_v.\cos^2 \theta_i + K_1.\sin^2 \theta_i)x_i + K_2.\sin \theta_i)$$

$$= 0$$

$$A_{\alpha\alpha} = \Sigma((K_v.\cos^2 \theta_i + K_1.\sin^2 \theta_i)x_i^2 + (K_2 + K_3)x_i.\sin \theta_i + K_4)$$

$$= 30859793$$



- Pergeseran pada pusat tumpuan

Koefisien yang telah dihitung digunakan untuk menyelesaikan persamaan sehingga didapatkan nilai pergeseran pada pusat tumpuan. Persamaan tersebut adalah:

$$A_{xx} \cdot \delta x + A_{xy} \cdot \delta y + A_{x\alpha} \cdot \alpha = H_0$$

$$A_{yx} \cdot \delta x + A_{yy} \cdot \delta y + A_{y\alpha} \cdot \alpha = V_0$$

$$A_{\alpha x} \cdot \delta x + A_{\alpha y} \cdot \delta y + A_{\alpha\alpha} \cdot \alpha = M_0$$

$$\begin{bmatrix} A_{xx} & A_{yx} & A_{\alpha x} \\ A_{xy} & A_{yy} & A_{\alpha y} \\ A_{x\alpha} & A_{y\alpha} & A_{\alpha\alpha} \end{bmatrix} * \begin{bmatrix} \delta x \\ \delta y \\ \alpha \end{bmatrix} = \begin{bmatrix} H_0 \\ V_0 \\ M_0 \end{bmatrix}$$

$$\begin{bmatrix} 707493,85 & 0 & -377667,30 \\ 0 & 928200,8 & 0 \\ -377667,30 & 0 & 30859792,67 \end{bmatrix} * \begin{bmatrix} \delta x \\ \delta y \\ \alpha \end{bmatrix} = \begin{bmatrix} 577,088 \\ 1308,505 \\ 1268,459 \end{bmatrix}$$

$$\begin{bmatrix} 0,0000014 & 0 & 0,000000017 \\ 0 & 0,0000011 & 0 \\ 0,0000000174 & 0 & 0,000000033 \end{bmatrix} * \begin{bmatrix} 577,088 \\ 1308,505 \\ 1268,459 \end{bmatrix} = \begin{bmatrix} \delta x \\ \delta y \\ \alpha \end{bmatrix}$$

Dengan perhitungan di atas didapat pergeseran pada setiap tiang sebagai berikut:

$$\delta x = 0,00084 \text{ cm}$$

$$\delta y = 0,00141 \text{ cm}$$

$$\alpha = 0,00005 \text{ rad}$$

- d. Pergeseran pada setiap kepala tiang

$$\text{Karena, } \delta'x_i = \delta x \cdot \cos \theta_i - (\delta y + \alpha \cdot x_i) \sin \theta_i$$

$$\text{Tiang 1-8, } x_i = 0, \text{ sehingga } \delta'x_i = 0,00084 \text{ cm}$$

$$\text{Karena, } \delta'y_i = \delta x \cdot \sin \theta_i + (\delta y + \alpha \cdot x_i) \cos \theta_i$$

$$\text{Tiang 1, } x_i = 8,75 \text{ maka } \delta'y_i = 0,00186 \text{ cm}$$

$$\text{Tiang 2, } x_i = 6,25 \text{ maka } \delta'y_i = 0,00173 \text{ cm}$$

$$\text{Tiang 3, } x_i = 3,75 \text{ maka } \delta'y_i = 0,00160 \text{ cm}$$

$$\text{Tiang 4, } x_i = 1,25 \text{ maka } \delta'y_i = 0,00147 \text{ cm}$$

$$\text{Tiang 5, } x_i = -1,25 \text{ maka } \delta'y_i = 0,00135 \text{ cm}$$

$$\text{Tiang 6, } x_i = -3,75 \text{ maka } \delta'y_i = 0,00122 \text{ cm}$$

$$\text{Tiang 7, } x_i = -6,25 \text{ maka } \delta'y_i = 0,00109 \text{ cm}$$

$$\text{Tiang 8, } x_i = -8,75 \text{ maka } \delta'y_i = 0,00096 \text{ cm}$$

## e. Gaya axial pada setiap tiang

$$\text{Karena, } P_{Ni} = K_v \cdot \delta' y_i$$

$$\text{Tiang 1, } P_{Ni} = 35,961 < Ra = 88,00 \text{ ton}$$

$$\text{Tiang 2, } P_{Ni} = 33,475$$

$$\text{Tiang 3, } P_{Ni} = 30,989$$

$$\text{Tiang 4, } P_{Ni} = 28,503$$

$$\text{Tiang 5, } P_{Ni} = 26,018$$

$$\text{Tiang 6, } P_{Ni} = 23,532$$

$$\text{Tiang 7, } P_{Ni} = 21,046$$

$$\text{Tiang 8, } P_{Ni} = 18,560 > Pa = -34,24 \text{ ton}$$

## f. Gaya dalam Arah Sumbu orthogonal untuk setiap tiang

$$\text{Karena, } P_{Hi} = K_1 \cdot \delta' x_i - K_2 \cdot \alpha$$

$$\text{Tiang 1-8, } P_{Hi} = 12,023 \text{ ton}$$

$$\text{Syarat, } P_{Hi} = 12,023 \text{ ton} < Ha = 22 \text{ ton}$$

## g. Momen pada kepala tiang

$$\text{Karena, } M_{ti} = -K_3 \cdot \delta' x_i + K_4 \cdot \alpha$$

$$\text{Tiang 1-8, } M_{ti} = -6,202 \text{ ton.m}$$

## h. Pemeriksaan arah axial

$$\Sigma H_i = P_{Hi} \times \text{jml tiang}$$

$$= 12,023 \times 48$$

$$= 577,088 \text{ ton}$$

$$\text{Syarat, } \Sigma H_i = H_o = 577,088 \text{ ton} \dots\dots\dots \text{OK!!!!}$$

$$\Sigma V_i = P_{Ni} \times \text{jml tiang}$$

$$\text{Tiang 1, } P_{Ni} = 35,961 \times 6 = 215,768$$

$$\text{Tiang 2, } P_{Ni} = 33,475 \times 6 = 200,852$$

$$\text{Tiang 3, } P_{Ni} = 30,989 \times 6 = 185,937$$

$$\text{Tiang 4, } P_{Ni} = 28,503 \times 6 = 171,021$$

$$\text{Tiang 5, } P_{Ni} = 26,018 \times 6 = 156,105$$

$$\text{Tiang 6, } P_{Ni} = 23,532 \times 6 = 141,190$$

$$\text{Tiang 7, } P_{Ni} = 21,046 \times 6 = 126,274$$

$$\text{Tiang 8, } P_{Ni} = 18,560 \times 6 = \underline{111,358} \pm$$

$$\text{Jumlah} = 1308,505 \text{ ton}$$

$$\text{Syarat, } \Sigma V_i = V_o = 1308,505 \text{ ton} \dots\dots\dots \text{OK!!!!}$$

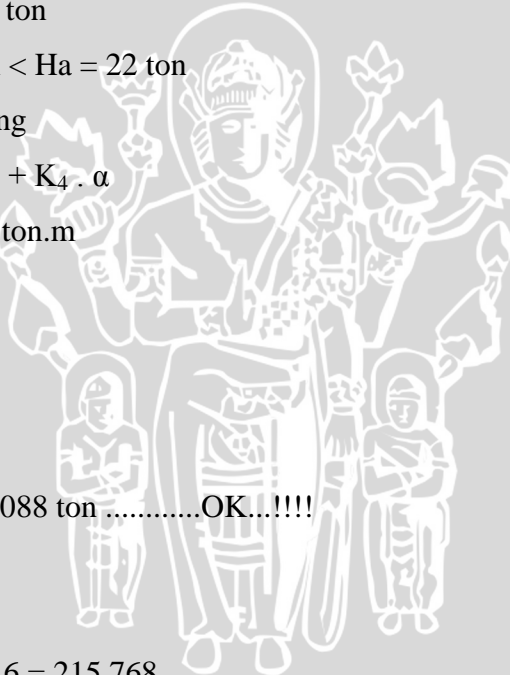

$$\Sigma M_i = (M_{ti} + V_i \cdot x_i) \cdot \text{jml tiang}$$

$$\text{Tiang 1, } -6,202 + (35,961 \times 8,75) \times 6 = 1850,76$$

$$\text{Tiang 2, } -6,202 + (33,475 \times 6,25) \times 6 = 1218,12$$

$$\text{Tiang 3, } -6,202 + (30,989 \times 3,75) \times 6 = 660,05$$

$$\text{Tiang 4, } -6,202 + (28,503 \times 1,25) \times 6 = 176,57$$

$$\text{Tiang 5, } -6,202 + (26,018 \times -1,25) \times 6 = -232,34$$

$$\text{Tiang 6, } -6,202 + (23,532 \times -3,75) \times 6 = -566,67$$

$$\text{Tiang 7, } -6,202 + (21,046 \times -6,25) \times 6 = -826,42$$

$$\text{Tiang 8, } -6,202 + (18,560 \times -8,75) \times 6 = \underline{-1011,60+}$$

$$\text{Jumlah} = 1268,46 \text{ ton.m}$$

$$\text{Syarat, } \Sigma M_i = M_o = 1268,46 \text{ ton..... OK..!!!}$$

Dari perhitungan di atas didapatkan:

Momen pada kepala tiang ( $M_{ti}$ ) keadaan normal = 1,901 tm = 19,01 kNm

Momen pada kepala tiang ( $M_{ti}$ ) keadaan normal = 6,202 tm = 62,02 kNm

Sehingga digunakan pancang dengan ukuran 40x40 cm dengan jumlah tulangan 5 batang berdiameter  $\frac{1}{2}$ " = 12,7 mm

#### 4.4.1.4. Analisis Penurunan Tiang

##### 4.4.1.4.1. Penurunan Pada Tiang Gesek (*Friction Pile*)

Pada waktu tiang dibebani, tiang akan mengalami pemendekan dan tanah di sekitarnya akan mengalami penurunan. Beberapa metode hitungan penurunan telah diusulkan, yaitu penurunan tiang tunggal dan kelompok tiang. Penurunan tiang tunggal yang terletak pada tanah homogen dengan modulus elastis dan rasio Poisson yang konstan dapat dihitung dengan persamaan (2-57) dan (2-58) yang disarankan oleh Poulos dan Davis (1980) sebagai berikut:

$$S = \frac{Q \cdot I}{E_s \cdot d}$$

$$I = I_o \cdot R_k \cdot R_h \cdot R_\mu$$

dimana:

$$Q = 29,57 \text{ ton}$$

$$= 295,67 \text{ kN}$$

$$d = 0,40 \text{ m}$$

$$E_s = 8 \cdot 10^4 \text{ kN/m}^2 \text{ (Tabel 2.5)}$$

$$E_p = 2,1 \cdot 10^7 \text{ kN/m}^2$$

$$\mu = 0,30 \text{ (Tabel 2.6)}$$

1.  $I_o$  (Faktor pengaruh penurunan untuk tiang yang tidak mudah mampat dalam massa semi tak terhingga)

dimana:

$$d_b = \text{diameter dasar tiang}$$

$$= 0,40 \text{ m}$$

$$d = \text{diameter kepala tiang}$$

$$= 0,40 \text{ m}$$

$$L = \text{panjang tiang}$$

$$= 6,00 \text{ m}$$

$$\diamond d_b/d = 0,40/0,40$$

$$= 1$$

$$\diamond L/d = 6,00/0,40$$

$$= 15$$

Selanjutnya, lihat Gambar 2.6. maka didapatkan nilai  $I_o = 0,12$

2.  $R_k$  (faktor reduksi kemudah-mampatan tiang)

dimana:

$$\diamond Ra = \frac{A_p}{d^2}$$

$$= \frac{d^2}{d^2} = \frac{0,40^2}{0,40^2} = 1$$

$$\diamond K = E_p \frac{Ra}{E_s}$$

$$= 2,1 \cdot 10^7 \frac{1}{8 \cdot 10^4}$$

$$= 262,738$$

Selanjutnya, lihat Gambar 2.7. maka didapatkan nilai  $R_k = 1,20$

3.  $R_h$  (faktor koreksi untuk ketebalan lapisan yang terletak pada tanah keras)

dimana:

$$h = 6,00 \text{ m}$$

$$\diamond L/d = 6,00/0,40$$

$$= 15,00$$

$$\diamond h/L = 6,00/6,00$$

$$= 1,00$$

Selanjutnya, lihat Gambar 2.8. maka didapatkan nilai  $R_h = 0,18$

4.  $R_\mu$  (faktor koreksi angka Poisson  $\mu$ )

dimana:

$$L/d = 15,00$$

$$K = 262,738$$

Selanjutnya, lihat Gambar 2.9. maka didapatkan nilai  $R_\mu = 0,92$

Penurunan tiang tunggal dapat dilihat pada perhitungan sebagai berikut:

$$\begin{aligned} \diamond I &= I_o \cdot R_k \cdot R_h \cdot R_\mu \\ &= 0,12 \cdot 1,20 \cdot 0,18 \cdot 0,92 \\ &= 0,024 \end{aligned}$$

$$\begin{aligned} \diamond S &= \frac{QI}{E_s \cdot d} \\ &= \frac{295,67 \cdot 0,024}{8 \cdot 10^4 \cdot 0,40} \\ &= 0,00022 \text{ m} = 0,022 \text{ cm} \end{aligned}$$

Perhitungan penurunan kelompok tiang dapat dihitung menggunakan persamaan (2-62) sebagai berikut:

$$\frac{S_g}{S} = \frac{(4B+3)^2}{(B+4)^2}$$

dimana:

$$S = 0,00022 \text{ m}$$

$$B = 17,900 \text{ m}$$

$$\frac{S_g}{S} = \frac{(4B+3)^2}{(B+4)^2}$$

$$\frac{S_g}{0,00022} = \frac{(4 \cdot 17,900 + 3)^2}{(17,900 + 4)^2}$$

$$\frac{S_g}{0,0002} = \frac{5565,16}{479,61}$$

$$S_g = 0,0026 \text{ m} = 0,2557 \text{ cm}$$

#### 4.4.1.4.2. Penurunan Pada Ujung Tiang (*Endbearing Pile*)

Beban bangunan seluruhnya didukung tiang oleh tahanan ujungnya (tiang dukung ujung), maka penurunan dihitung dengan menganggap dasar kelompok tiang sebagai rakit, dengan luas dasar yang sama dengan luas kelompok tiang. Pada tiang dukung, beban struktur didukung sepenuhnya oleh lapisan tanah keras yang terletak pada dasar atau ujung bawah tiang. Penurunan tiang tunggal dapat dihitung dengan persamaan (2-59) dan (2-60) sebagai berikut:



$$S = \frac{Q \cdot I}{E_s \cdot d}$$

$$I = I_o \cdot R_k \cdot R_b \cdot R_\mu$$

dimana:

$$Q = 29,57 \text{ ton}$$

$$= 295,67 \text{ kN}$$

$$d = 0,40 \text{ m}$$

$$E_s = 8 \cdot 10^4 \text{ kN/m}^2 \text{ (Tabel 2.5)}$$

$$E_p = 2,1 \cdot 10^7 \text{ kN/m}^2$$

$$\mu = 0,30 \text{ (Tabel 2.6)}$$

1.  $I_o$  (Faktor pengaruh penurunan untuk tiang yang tiasak mudah mampat dalam massa semi tak terhingga)

dimana:

$d_b$  = diameter dasar tiang

$$= 0,40 \text{ m}$$

$d$  = diameter kepala tiang

$$= 0,40 \text{ m}$$

$L$  = panjang tiang

$$= 6,00 \text{ m}$$

$$\diamond d_b/d = 0,40/0,40$$

$$= 1$$

$$\diamond L/d = 6,00/0,40$$

$$= 15$$

Selanjutnya, lihat Gambar 2.6. maka didapatkan nilai  $I_o = 0,12$

2.  $R_k$  (faktor reduksi kemudah-mampatan tiang)

dimana:

$$\diamond Ra = \frac{A_p}{d^2}$$

$$= \frac{d^2}{d^2} = \frac{0,40^2}{0,40^2} = 1$$

$$\diamond K = E_p \frac{Ra}{E_s}$$

$$= 2,1 \cdot 10^7 \frac{1}{8 \cdot 10^4}$$

$$= 262,738$$

Selanjutnya, lihat Gambar 2.7. maka didapatkan nilai  $R_k = 1,2$

3.  $R_b$  (faktor koreksi untuk kekakuan lapisan pendukung)

dimana:

$$R_a = 1,0$$

$$K = 262,73$$

$$L/d = 15$$

$E_s$  = Modulus elastis tanah disekitar tiang

$$= 8.10^4 \text{ kN/m}^2$$

$E_b$  = Modulus elastis tanah pada dasar tiang

$$= 2.10^5 \text{ kN/m}^2$$

$$E_b/E_s = 2.10^5 / 8.10^4$$

$$= 2,5$$

Selanjutnya, lihat Gambar 2.10. maka didapatkan nilai  $R_b = 0,84$

4.  $R_\mu$  (faktor koreksi angka Poisson  $\mu$ )

dimana:

$$L/d = 15,00$$

$$K = 262,738$$

Selanjutnya, lihat Gambar 2.9. maka didapatkan nilai  $R_\mu = 0,92$

Penurunan tiang tunggal dapat dilihat pada perhitungan sebagai berikut:

$$\diamond I = I_o \cdot R_k \cdot R_b \cdot R_\mu$$

$$= 0,12 \cdot 1,20 \cdot 0,84 \cdot 0,92$$

$$= 0,111$$

$$\diamond S = \frac{Q \cdot I}{E_s \cdot d}$$

$$= \frac{295,67 \cdot 0,111}{8.10^4 \cdot 0,40}$$

$$= 0,00103 \text{ m} = 0,103 \text{ cm}$$

Perhitungan penurunan kelompok tiang dapat dihitung menggunakan persamaan (2-63) sebagai berikut:

$$\frac{S_g}{S} = \frac{(4B+3)^2}{(B+4)^2}$$

dimana:

$$S = 0,00079 \text{ m}$$

$$B = 17,900 \text{ m}$$

$$\frac{S_g}{S} = \frac{(4B+3)^2}{(B+4)^2}$$

$$\frac{S_g}{0,00103} = \frac{(4 \cdot 17,900 + 3)^2}{(17,900 + 4)^2}$$

$$\frac{S_g}{0,00103} = \frac{5565,16}{479,61}$$

$$S_g = 0,0119 \text{ m} = 1,193 \text{ cm}$$

#### 4.4.2. Desain Pondasi Tiang Pada Pintu Penguras (*Sluice Gate*)

Elevasi dasar pondasi bangunan terletak pada elevasi 54,00 m pada kedalaman 10,50 m dari titik pengeboran awal dengan nilai SPT 31. Gambar dari susunan kelompok tiang dapat dilihat pada Gambar 4.40.

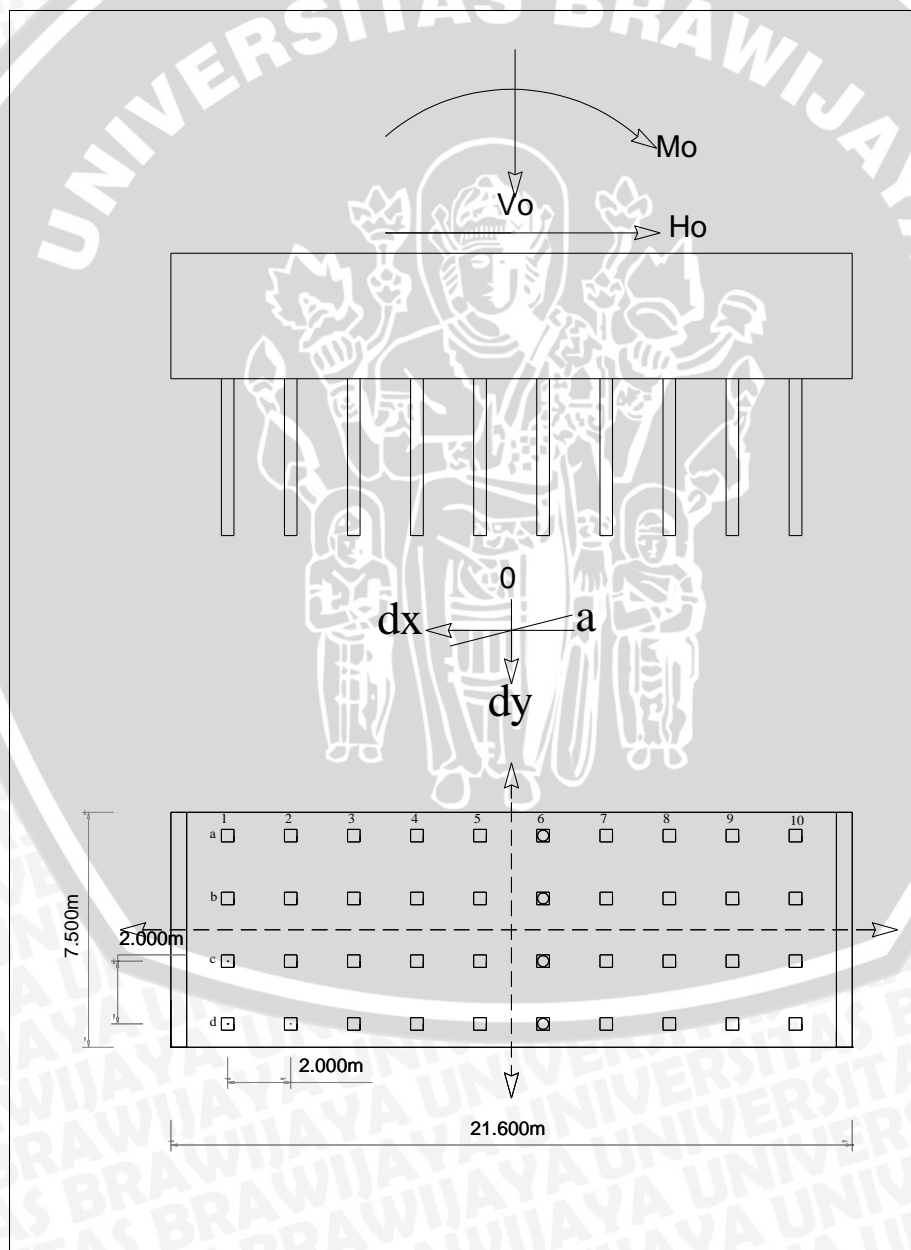

Gambar 4.40. Desain Kelompok Tiang Pintu Penguras (*Sluice Gate*)



#### 4.4.3. Desain Pondasi Tiang Pada Dinding Penahan Bagian Hulu

Elevasi dasar pondasi bangunan terletak pada elevasi 56,00 m pada kedalaman 8,50 m dari titik pengeboran awal dengan nilai SPT 49. Gambar dari susunan kelompok tiang dapat dilihat pada Gambar 4.41.

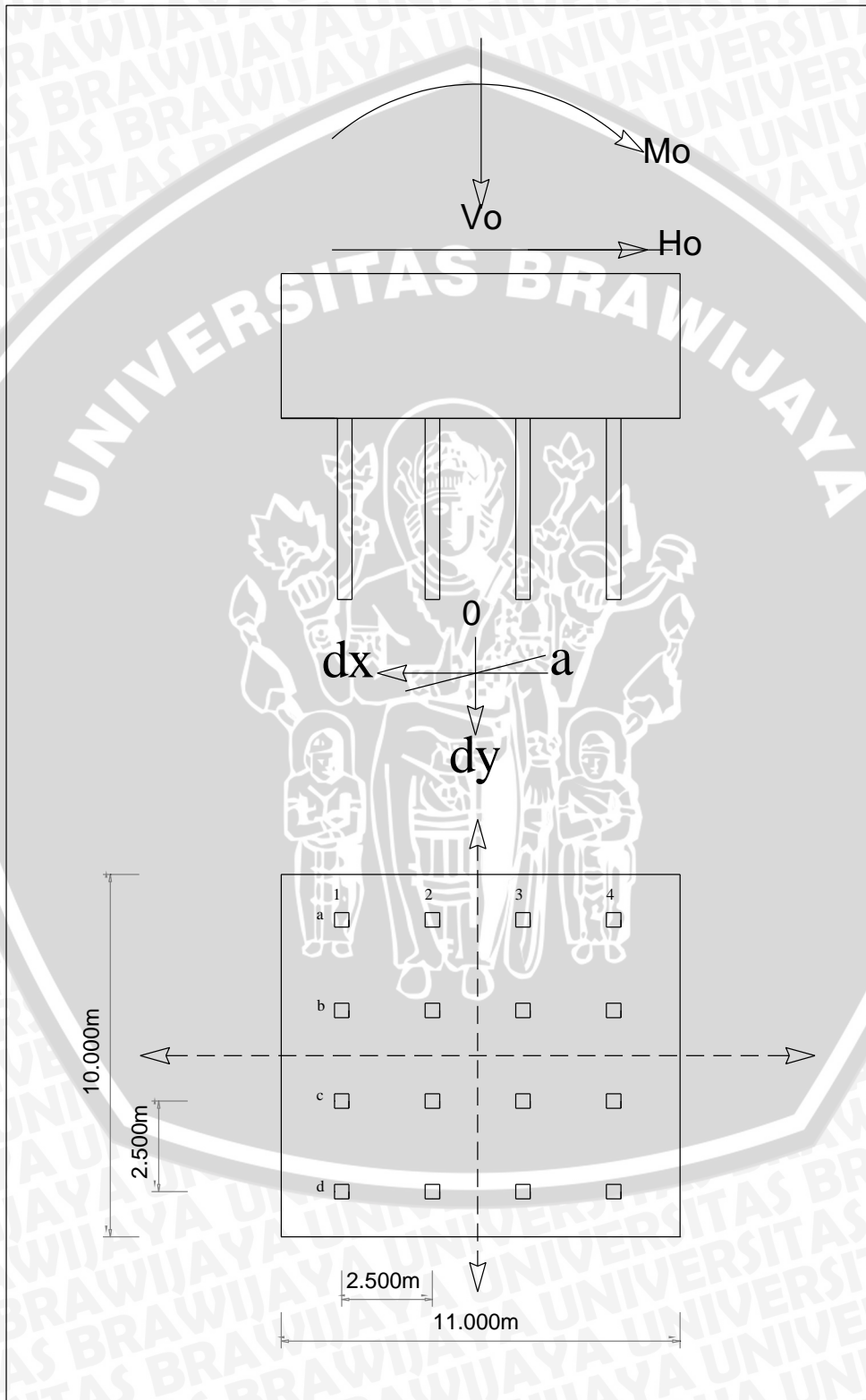

Gambar 4.41. Desain Kelompok Tiang Dinding Penahan Bagian Hulu

#### 4.4.4. Desain Pondasi Tiang Pada Dinding Penahan Bagian Jembatan

Elevasi dasar pondasi bangunan terletak pada elevasi 56,00 m pada kedalaman 8,50 m dari titik pengeboran awal dengan nilai SPT 49. Gambar dari susunan kelompok tiang dapat dilihat pada Gambar 4.42.

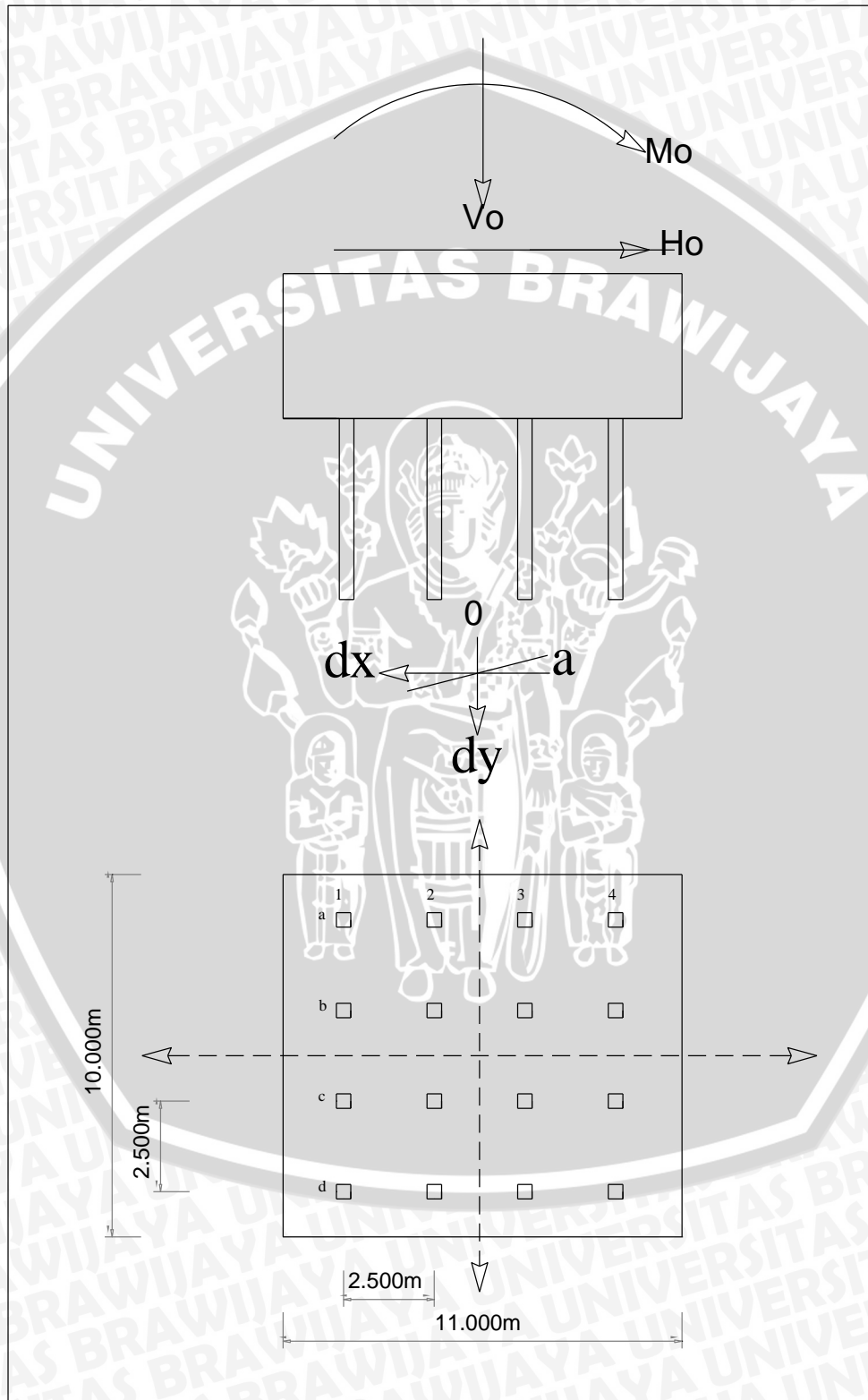

Gambar 4.42. Desain Kelompok Tiang Dinding Penahan Bagian Jembatan

#### 4.4.5. Desain Pondasi Tiang Pada Dinding Penahan Bagian Hilir

Elevasi dasar pondasi bangunan terletak pada elevasi 52,00 m pada kedalaman 8,50 m dari titik pengeboran awal dengan nilai SPT 39. Gambar dari susunan kelompok tiang dapat dilihat pada Gambar 4.43.

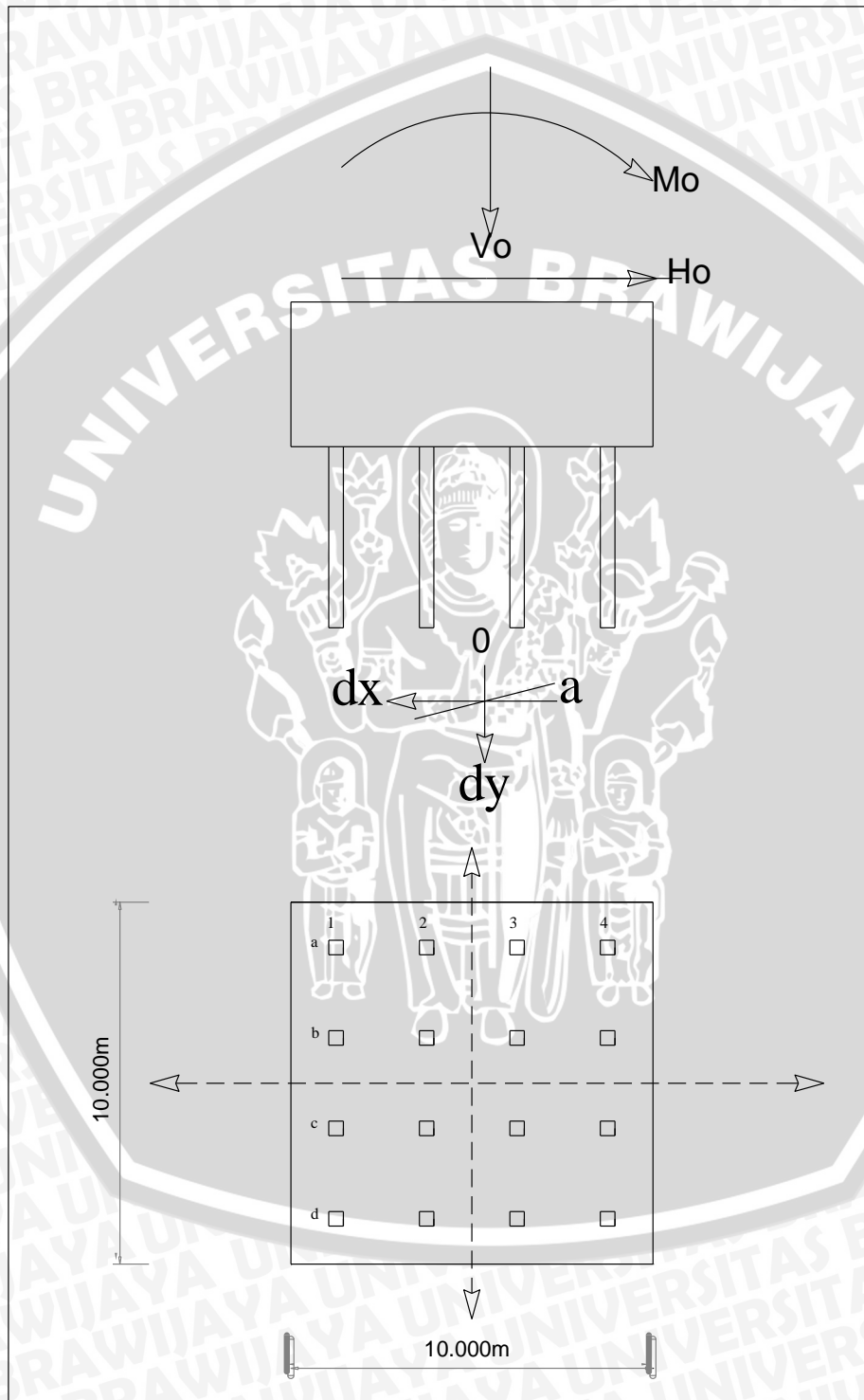

**Gambar 4.43. Desain Kelompok Tiang Dinding Penahan Bagian Hilir**

Rekapitulasi perhitungan pondasi tiang dapat dilihat pada Tabel 4.46 berikut ini:

Tabel 4.46. Rekapitulasi Perhitungan Pondasi Tiang

Bangunan Yang Ditinjau	Jumlah Tiang (Tiang)	Jarak Tulangan (m)	Kedalaman (m)	Ukuran Tiang (m <sup>2</sup> )	Momen Kepala Tiang kNm	Jumlah Tulangan	Penurunan	
							<i>Friction Pile</i> (m)	<i>Endbearing Pile</i> (m)
Bendung Gerak	48	2,5	6,00	0,40 x 0,40	62,02	5 $\phi$ ½"	0,0026	0,0119
Bangunan Penguras	40	2,0	6,00	0,40 x 0,40	59,28	5 $\phi$ ½"	0,0030	0,0140
Dinding Penahan Bagian Hulu	16	2,5	8,00	0,40 x 0,40	35,64	5 $\phi$ ½"	0,0022	0,0065
Dinding Penahan Bagian Jembatan	16	2,5	8,00	0,40 x 0,40	55,15	5 $\phi$ ½"	0,0035	0,0104
Dinding Penahan Bagian Hilir	16	2,5	4,00	0,40 x 0,40	78,77	5 $\phi$ ½"	0,0023	0,0242

Sumber: Hasil Perhitungan

#### 4.5. Analisis Beton Bertulang

Beton bertulang terdiri atas campuran semen, agregat halus/pasir, agregat kasar dan air. Bahan beton mempunyai sifat kuat menahan gaya tekan tetapi lemah terhadap gaya tarik, sehingga untuk penggunaan dalam bidang struktur dipakai secara bersamaan dengan baja tulangan.

Menurut peraturan beton di Indonesia (PBI 1971, diperbaiki dengan SK SNI T-15-1991-03 dan SNI 03-2847-2002), kuat tekan beton diberi notasi dengan  $f_c'$ , yaitu kuat tekan silinder beton yang disyaratkan pada waktu berumur 28 hari. Mutu beton dibedakan atas 3 macam menurut kuat tekannya, yaitu:

1. Mutu beton dengan  $f_c'$  kurang dari 10 Mpa, digunakan untuk beton non struktur (misalnya: kolom praktis, balok praktis).
2. Mutu beton dengan  $f_c'$  antara 10 Mpa sampai 20 Mpa, digunakan untuk beton struktur (misalnya: balok, kolom, pelat maupun pondasi).
3. Mutu beton dengan  $f_c'$  sebesar 20 Mpa ke atas, digunakan untuk struktur beton yang direncanakan tahan gempa.

Jenis baja tulangan menurut SNI 03-2847-2002, tulangan yang dapat digunakan pada elemen dan kawat baja saja. Belum ada peraturan yang mengatur penggunaan tulangan lain, selain dari baja tulangan atau kawat baja. Baja tulangan yang tersedia dipasaran ada 2 jenis, yaitu baja tulangan polos (BJTP) dan baja tulangan ulir atau *deform* (BJTD). Tegangan leleh ( $f_y$ ) minimal sebesar 240 MPa.

Penggabungan antara dua jenis bahan dengan kuat tekan beton  $f_c' = 20$  MPa dan tegangan leleh baja  $f_y = 240$  MPa telah memenuhi persyaratan keamanan dalam perancangan struktur beton.

Untuk memperoleh hasil yang maksimal, perlu diperhatikan dalam proses pencampuran, pengecoran dan pemadatan di lapangan perlu diperhatikan. Dalam perawatan beton setelah konstruksi selesai dibangun juga harus diperhatikan.

Untuk beton bertulang pada bangunan yang dianalisis pada studi ini menggunakan:

$f_c'$	= 20 MPa
$f_y$	= 240 MPa
p (tebal selimut beton)	= 100 mm

#### 4.5.1. Pilar pada Bendung Gerak (*Barrage*)

Dalam analisis struktur pembeconan dan penulangan pilar pada bendung gerak (*barrage*) perlu dilakukan anggapan atau asumsi. Adapun asumsi perhitungannya adalah sebagai berikut:

1. Pilar I (menanggung beban rumah operasi dan jembatan pelayanan) dan Pondasi Telapak Pilar I
2. Pilar II (menanggung beban jembatan kendaraan) dan Pondasi Telapak Pilar II
3. Pilar III, IV dan V (menanggung beban sendiri)
4. Pelimpah (menanggung beban air dan pintu)
5. Pelat Pondasi pada Bendung Gerak (*Barrage*)

##### 4.5.1.1. Pilar I dan Telapak Pondasi Pilar I

Perencanaan penulangan pada tubuh pilar berdasarkan luas penampang tubuh pilar serta momen lentur dan gaya tekan sentris akibat berat struktur di atasnya. Gaya dan momen lentur yang bekerja pada pilar dapat dilihat pada Tabel. 4.47 sedangkan gambar pilar dan diagram gaya yang bekerja pada pilar dapat dilihat pada Gambar 4.44 dan Gambar 4.45.

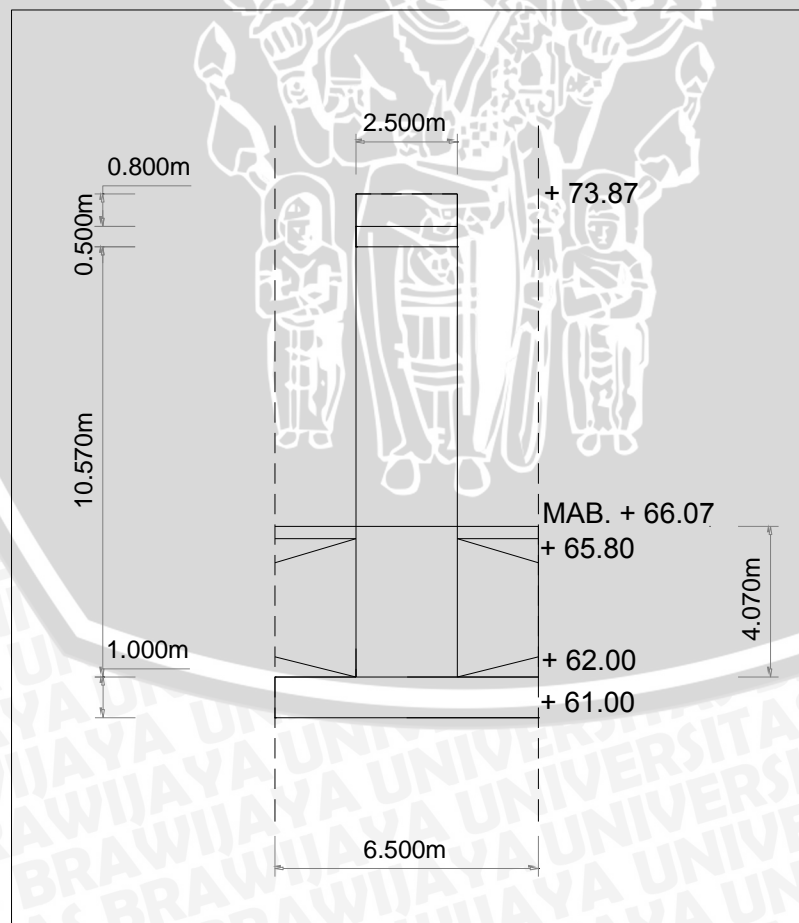

Gambar 4.44. Pilar I Kondisi Muka Air Banjir Gempa (Tampak Depan)

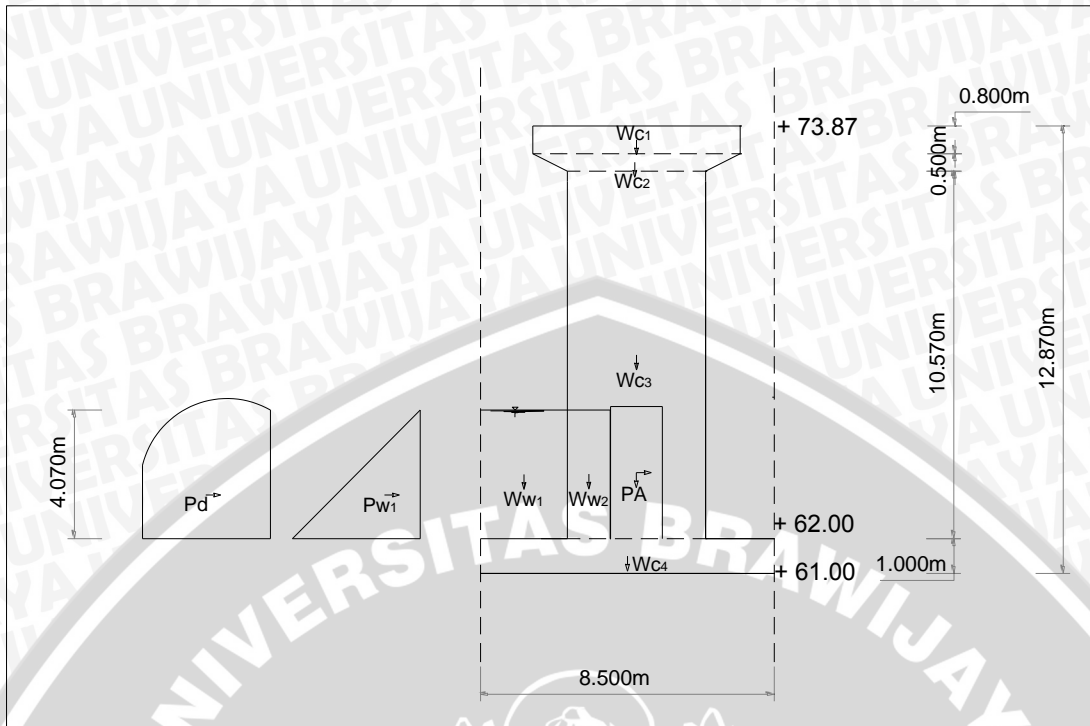

**Gambar 4.45. Diagram Gaya Pada Pilar I Kondisi Muka Air Banjir Gempa (Tampak Samping)**

**Tabel 4.47. Gaya dan Momen Pilar pada Rumah Operasi Pintu Akibat Gempa**

Notasi	Nilai						Gaya		Lengan Momen	Momen
	Lebar	Tinggi	Panjang	Ratio	$\gamma$	Pv	Ph	y	My	
	(m)	(m)	(m)		( $t/m^3$ )	(ton)	(ton)	(m)	(ton.m)	
	[1]	[2]	[3]	[4]	[5]	[6]	[7]	[8]	[9]	
WRP						= 59,750	8,963	14,870	133,272	
Wc1	4,000	x 0,800	x 2,500	x 1,000	x 2,400	= 19,200	2,880	12,470	35,914	
Wc2	4,000	x 0,500	x 2,500	x 1,000	x 2,400	= 12,000	1,800	11,820	21,276	
Wc3	4,000	x 10,570	x 2,500	x 1,000	x 2,400	= 253,680	38,052	6,285	239,157	
Pw1	4,070	x 4,070	x 6,500	x 0,500	x 1,000	=	53,836	1,357	73,037	
Pd	4,070	x 4,070	x 6,500	x 7/12	x 1,000	=	9,421	1,357	12,782	
Total						$\Sigma V$	344,630	$\Sigma Mh$	515,438	
						$\Sigma H$				

Sumber: Hasil Perhitungan

$P_u = 1,200 \times \Sigma V$ $= 1,200 \times 344,630$ $= 413,556 \text{ ton}$	$M_u = 1,200 \times M_h$ $= 1,200 \times$ $= 618,53 \text{ ton}$
--	--

Keterangan:

- [ 1 ] = lebar tiap bagian (m)
- [ 2 ] = tinggi tiap bagian (m)
- [ 3 ] = panjang konstruksi
- [ 4 ] = 1 digunakan untuk penampang persegi atau persegi panjang  
 = 0,5 digunakan untuk penampang segitiga

- [ 5 ] = berat jenis beton bertulang =  $2,4 \text{ (t/m}^3\text{)}$   
 = berat jenis air =  $1,0 \text{ (t/m}^3\text{)}$
- [ 6 ] = gaya vertikal (ton)  
 = [ 1 ] \* [ 2 ] \* [ 3 ] \* [ 4 ] \* [ 5 ] (untuk bangunan dan timbunan)  
 nilai (+) untuk arah gaya ke bawah  
 nilai (-) untuk arah gaya ke atas
- [ 7 ] = gaya horizontal (ton)  
 = [ 6 ] \* kh , dengan kh = 0,15 (untuk berat bangunan)  
 =  $7/12 * [ 1 ] * [ 2 ] * [ 3 ] * [ 4 ] * [ 5 ] * kh$  (untuk tekanan air dinamis)  
 nilai (+) untuk arah gaya ke hilir  
 nilai (-) untuk arah gaya ke hulu
- [ 8 ] = lengan momen gaya berat konstruksi (m)
- [ 9 ] = momen (ton.m)  
 = [ 7 ] \* [ 8 ]

#### Data Pilar I :

1. Lebar (h) = 4,00 m
2. Tebal (b) = 2,50 m
3. Tinggi = 11,87 m
4. Mutu Bahan
  - Beton ( $f_c'$ ) = 20,00 Mpa
  - Baja ( $f_y$ ) = 240,00 Mpa
5. Beban pada Pilar
  - a. Pu = 4135,56 kN
  - b. Mu = 6185,25 kN.m

#### a. Kontrol Kelangsingan

Pilar diasumsikan sebagai kolom tanpa pengaku, dibagian atas dan bawahnya jepit-jepit, maka  $k = 1,00$  (Tabel 2.7). Kelangsingan kolom dapat dihitung menggunakan persamaan (2-94) dan persamaan (2-95) sebagai berikut:

dimana:

$$\begin{aligned} A &= b.h \\ &= 2,5 \times 4,0 \\ &= 10,00 \text{ m}^2 \end{aligned}$$



$$I = \frac{1}{12} \cdot b \cdot h^3$$

$$= \frac{1}{12} \cdot 2,5 \cdot (4,0)^3$$

$$= 13,333 \text{ m}^4$$

$$r = \sqrt{\frac{I}{A}}$$

$$= \sqrt{\frac{13,33}{10,00}} = 1,155 \text{ m}$$

$$k \frac{\lambda_{n,k}}{r} < 22$$

$$1,0 \frac{11,87}{1,155} < 22$$

$$10,28 < 22 \text{ (Termasuk Kolom Pendek)}$$

**b. Luas Penampang Pilar**

$$\text{Agr} = \text{Lebar} \times \text{Tebal}$$

$$= 4,00 \times 2,50$$

$$= 10,00 \text{ m}^2$$

$$= 10^7 \text{ mm}^2$$

**c. Tulangan Kolom**

Pada sumbu vertikal

$$\frac{P_u}{\phi \cdot \text{Agr} \cdot 0,85 \cdot f_c'} = \frac{4135,56 \cdot 10^3}{0,65 \cdot 10^7 \cdot 0,85 \cdot 20,00}$$

$$= 0,037 < 0,10$$

ø ditingkatkan menjadi 0,80 maka:

$$\frac{P_u}{\phi \cdot \text{Agr} \cdot 0,85 \cdot f_c'} = \frac{4135,56 \cdot 10^3}{0,80 \cdot 10^7 \cdot 0,85 \cdot 20,00}$$

$$= 0,030 < 0,10$$

$$e_t = \frac{M_u}{P_u}$$

$$= \frac{6185,25}{4135,56}$$

$$= 1,496 \text{ m}$$

$$e_t/h = 1495,63/4000 = 0,37$$

Pada sumbu horizontal

$$\frac{P_u}{\phi \cdot \text{Agr} \cdot 0,85 \cdot f_c'} \left( \frac{e_t}{h} \right) = 0,030 \cdot 0,37$$

$$= 0,011$$

$$\text{Dengan } d'/h = 1000/4000 = 0,25 \text{ diambil } d'/h = 0,10$$

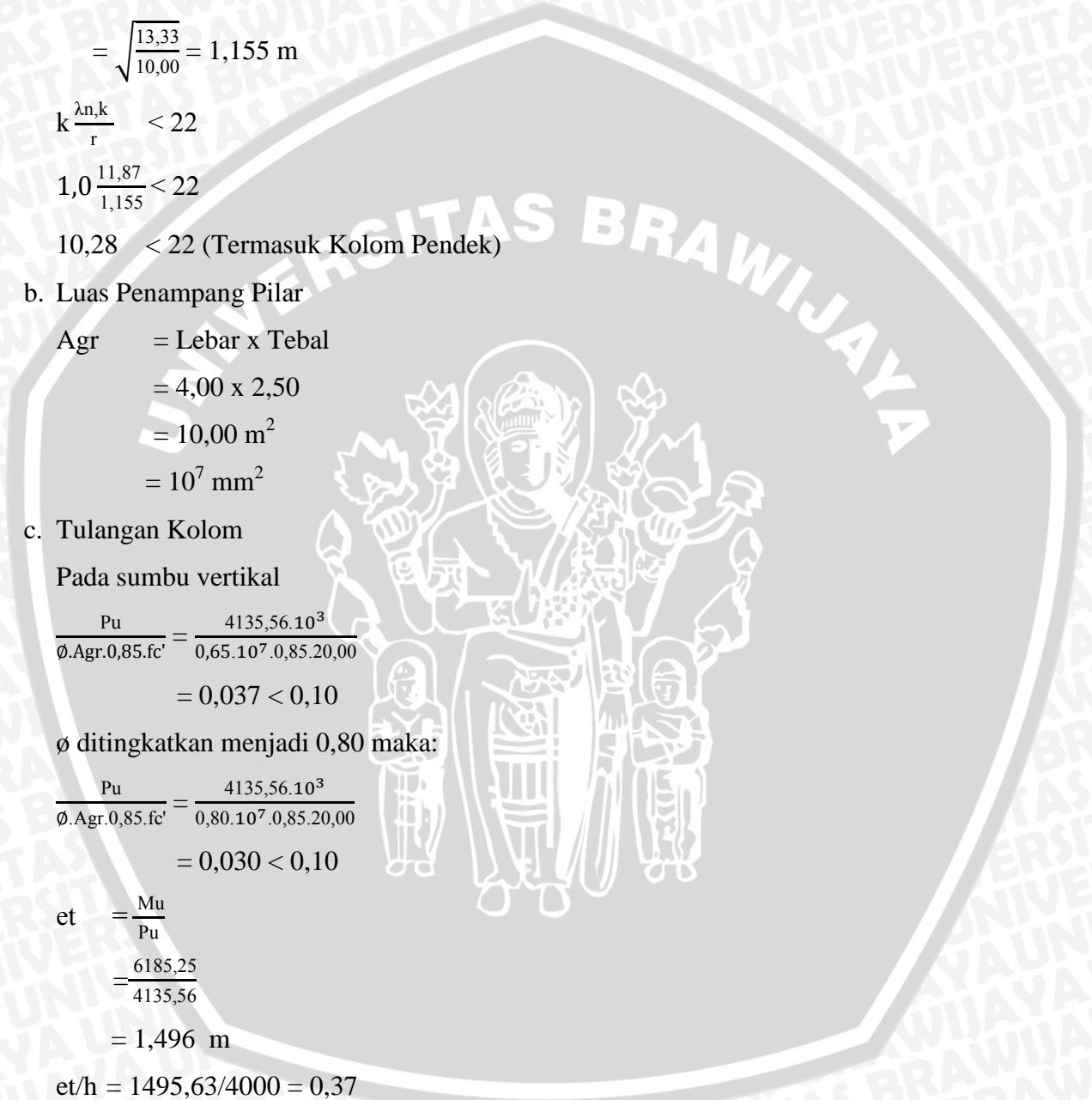

Berdasarkan grafik pada Gambar 2.14, maka diperoleh  $r = 0,003$  dan  $\beta = 0,80$

$$\begin{aligned}\rho &= \beta \cdot r \\ &= 0,80 \cdot 0,003 \\ &= 0,0024\end{aligned}$$

$$\begin{aligned}A_g \text{ total} &= \rho \cdot A_{gr} \\ &= 0,0024 \cdot 10^7 \\ &= 24000 \text{ mm}^2 \\ &= 240 \text{ cm}^2\end{aligned}$$

Dipakai: Tulangan utama 97 D 19-125  $\text{mm}^2 = 27500 \text{ mm}^2 > 24000 \text{ mm}^2$

d. Begel pada Kolom

$$\text{Tebal selimut beton (ds)} = 100 \text{ mm}$$

$$\begin{aligned}d &= h - ds \\ &= 4000 - 100 \\ &= 3900 \text{ mm}\end{aligned}$$

1. Gaya geser perlu kolom ( $V_{u,k}$ )

$$\begin{aligned}V_{u,k} &= \frac{M_{u2} - M_{u1}}{\lambda_k} \\ &= \frac{5929,15}{11187} \\ &= 499,51 \text{ kN} \\ &= 499507,17 \text{ N}\end{aligned}$$

2. Gaya geser yang ditahan oleh beton ( $V_c$ )

$$\begin{aligned}V_c &= \left(1 + \frac{N_{u,k}}{14 \cdot A_g}\right) \frac{\sqrt{f_c'}}{6} \cdot b \cdot d \\ &= \left(1 + \frac{4135,56}{14 \cdot 2500 \cdot 4000}\right) \frac{\sqrt{20}}{6} \cdot 2500 \cdot 3900 \\ &= 7481892,557 \text{ N}\end{aligned}$$

3. Gaya geser yang ditahan oleh beton ( $V_s$ ) dan  $V_{s,\text{maks}}$

$$\begin{aligned}V_s &= \frac{V_u - \phi \cdot V_c}{\phi} \text{ dengan } \phi = 0,75 \\ &= \frac{499507,17 - 7481892,557}{0,75} \text{ dengan } \phi = 0,75 \\ &= -6815882,996 \text{ N}\end{aligned}$$

$$\begin{aligned}V_{s,\text{maks}} &= \frac{2}{3} \cdot \sqrt{f_c'} \cdot b \cdot d \\ &= \frac{2}{3} \cdot \sqrt{20} \cdot 2500 \cdot 3900 \\ &= 29068883,71 \text{ N, syarat } V_s \leq V_{s,\text{maks}} \dots \text{ OK}\end{aligned}$$

4. Luas begel perlu ( $A_{v,u}$ ) untuk setiap panjang kolom  $S = 1000$  mm, dengan memilih yang terbesar dari nilai  $A_v$  berikut:

$$\begin{aligned} A_v &= \frac{V_s \cdot S}{f_y \cdot d} \\ &= \frac{-6815882,996 \cdot 1000}{240 \cdot 3900} \\ &= -7281,93 \text{ mm}^2 \end{aligned}$$

$$\begin{aligned} A_v &= \frac{b \cdot s}{3 \cdot f_y} \\ &= \frac{2500 \cdot 1000}{3 \cdot 240} \\ &= 3472,2 \text{ mm}^2 \end{aligned}$$

$$\begin{aligned} A_v &= \frac{75 \sqrt{f_c'} \cdot b \cdot s}{1200 \cdot f_y} \\ &= \frac{75 \sqrt{20'} \cdot 2500 \cdot 1000}{1200 \cdot 240} \\ &= 2911,55 \text{ mm}^2 \end{aligned}$$

Dipilih yang paling besar, jadi  $A_{v,u} = 3472,2 \text{ mm}^2$

Digunakan begel 2 kaki dengan  $d_p = 10$  mm

5. Jarak antar begel

$$\begin{aligned} s &= \frac{\frac{n}{4} \cdot \pi \cdot d_p^2 \cdot S}{A_{v,u}} \\ &= \frac{\frac{2}{4} \cdot \pi \cdot 10^2 \cdot 1000}{3472,2} \\ &= 45,24 \text{ mm} \end{aligned}$$

Kontrol jarak:

$$s \leq 16D = 304 \text{ mm}$$

$$s \leq 48 \cdot d_p = 480 \text{ mm}$$

$$s \leq d/2 = 1950 \text{ mm}$$

$$s \leq 600 \text{ mm}$$

Dipakai nilai terkecil dan dibulatkan ke bawah, yaitu  $s = 45 \text{ mm} \leq 45,24$

(Dibaca: "Begel 2 kaki berdiameter polos 10 mm dan berjarak 45 mm")

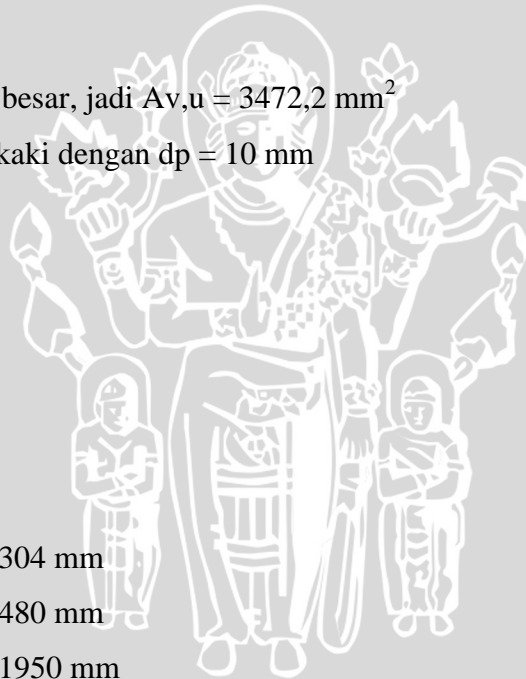

## e. Telapak Pondasi

Gaya dan momen yang bekerja pada pondasi telapak dapat dilihat pada Tabel. 4.48.

**Tabel 4.48. Gaya dan Momen Pondasi Telapak Akibat Gempa**

Notasi	Nilai					Gaya		Lengan Momen	Momen				
	Lebar (m)		Tinggi (m)		Panjang (m)	Ratio	$\gamma$ ( $t/m^3$ )	Pv (ton)	Ph (ton)	y (m)	My (ton.m)		
	[1]		[2]		[3]	[4]	[5]	[6]	[7]	[8]	[9]		
RP								= 59,750	8,963	14,870	133,272		
PA								31,949	4,792	2,900	13,898		
Wc1	4,000	x	0,800	x	2,500	x	1,000	x	2,400	= 19,200	2,880	12,470	35,914
Wc2	4,000	x	0,500	x	2,500	x	1,000	x	2,400	= 12,000	1,800	11,820	21,276
Wc3	4,000	x	10,570	x	2,500	x	1,000	x	2,400	= 253,680	38,052	6,285	239,157
Wc4	8,500	x	1,000	x	6,500	x	1,000	x	2,400	= 132,600	19,890	0,500	9,945
Ww1	2,511	x	4,070	x	6,500	x	1,000	x	1,000	= 66,429			
Ww2	1,250	x	4,070	x	4,000	x	1,000	x	1,000	= 20,350			
Pw1	4,070	x	4,070	x	6,500	x	0,500	x	1,000	=	53,836	1,357	73,037
Pd	4,070	x	4,070	x	6,500	x	7/12	x	1,000	=	9,421	1,357	12,782
Total								$\Sigma V$	595,957		$\Sigma Mh$	539,280	
								$\Sigma H$		139,634			

Sumber: Hasil Perhitungan

Pu	=	1,200	x	$\Sigma V$	Mu	=	1,200	x	$\Sigma Mh$
	=	1,200	x	595,957		=	1,200	x	539,280
	=	715,15	ton			=	647,137	ton	

## Keterangan:

[ 1 ] = lebar tiap bagian (m)

[ 2 ] = tinggi tiap bagian (m)

[ 3 ] = panjang konstruksi

[ 4 ] = 1 digunakan untuk penampang persegi atau persegi panjang  
= 0,5 digunakan untuk penampang segitiga

[ 5 ] = berat jenis beton bertulang = 2,4 ( $t/m^3$ )  
= berat jenis air = 1,0 ( $t/m^3$ )

[ 6 ] = gaya vertikal (ton)

= [ 1 ] \* [ 2 ] \* [ 3 ] \* [ 4 ] \* [ 5 ] (untuk bangunan dan timbunan )

nilai (+) untuk arah gaya ke bawah

nilai (-) untuk arah gaya ke atas

[ 7 ] = gaya horizontal (ton)

= [ 6 ] \* kh , dengan kh = 0,15 (untuk berat bangunan)

= 7/12 \* [ 1 ] \* [ 2 ] \* [ 3 ] \* [ 4 ] \* [ 5 ] \* kh (untuk tekanan air dinamis)

nilai (+) untuk arah gaya ke hilir

nilai (-) untuk arah gaya ke hulu

[ 8 ] = lengan momen gaya berat konstruksi (m)

[ 9 ] = momen (ton.m)

= [ 7 ] \* [ 8 ]

Data pondasi telapak:

1. Lebar (B) = 6,50 m
2. Panjang (L) = 8,50 m
3. Tebal (h) = 1,00 m
4. Panjang Kolom (hk) = 4,00 m
5. Lebar Kolom (bk) = 2,50 m
6. Tebal Selimut (ds) = 0,10 m
7. Mutu Bahan
  - Beton (fc') = 20,00 Mpa
  - Baja (fy) = 240 Mpa
8. Beban pada Pondasi Telapak
  - Pu = 7151,49 kN
  - Mu = 6471,37 kNm

Langkah perhitungan pondasi telapak adalah sebagai berikut:

1. Menghitung tegangan

$$\begin{aligned}\sigma_{\max,\min} &= \frac{P_{u,k}}{B.L} \pm \frac{M_{u,x}}{\frac{1}{6}.B.L^2} \\ &= \frac{7151,49}{6,50.8,50} \pm \frac{6471,37}{\frac{1}{6}.6,5.8,5^2}\end{aligned}$$

$$\begin{aligned}\sigma_{\max} &= 129,44 + 82,68 \\ &= 212,12 \text{ kN/m}^2\end{aligned}$$

$$\begin{aligned}\sigma_{\min} &= 129,44 - 82,68 \\ &= 46,76 \text{ kN/m}^2\end{aligned}$$

2. Kontrol Tegangan Geser 1 Arah

$$d_s = 100 \text{ mm}$$

$$\begin{aligned}d &= h - d_s \\ &= 1000 - 100 \\ &= 900 \text{ mm}\end{aligned}$$

$$\begin{aligned}a &= \frac{L}{2} - \frac{hk}{2} - d \\ &= \frac{8500}{2} - \frac{4000}{2} - 900 = 1350 \text{ mm} = 1,35 \text{ m}\end{aligned}$$

$$\begin{aligned}\sigma_a &= \sigma_{\min} + \frac{(L-a).(\sigma_{\max}-\sigma_{\min})}{L} \\ &= 46,76 + \frac{(8500-1350).(212,12-46,76)}{8500} = 185,86 \text{ kN/mm}^2\end{aligned}$$

Gaya tekan ke atas ( $V_u$ )

$$\begin{aligned} V_u &= a.B \left( \frac{\sigma_{\text{maks}} + \sigma_a}{2} \right) \\ &= 1,35.6,5 \left( \frac{212,12 + 185,86}{2} \right) \\ &= 1746,11 \text{ kN} \end{aligned}$$

Gaya geser yang dapat ditahan oleh beton ( $\phi V_c$ ) dengan  $\phi = 0,75$

$$\begin{aligned} V_c &= \frac{\sqrt{f'_c}}{6} B d \phi \\ &= \frac{\sqrt{20}}{6} 6500.900.0,75 \\ &= 3270,25 \text{ kN} \end{aligned}$$

Kontrol  $V_u = 1746,11 \text{ kN} \leq \phi.V_c = 3270,25 \text{ kN} \dots \text{OK}$

### 3. Kontrol Tegangan Geser 2 Arah (Geser Pons)

$$(b + d) = (2500 + 900) = 3400 \text{ mm} = 3,40 \text{ m}$$

$$(h + d) = (4000 + 900) = 4900 \text{ mm} = 4,90 \text{ m}$$

a. Gaya Tekan ke atas (Geser Pons)

$$\begin{aligned} V_u &= \{B.L - (b+d)(h+d)\} \left( \frac{\sigma_{\text{maks}} + \sigma_{\text{min}}}{L} \right) \\ &= \{8500.6500 - 3400.4900\} \left( \frac{212,12 + 46,76}{8500} \right) \\ &= 4995,04 \text{ kN} \end{aligned}$$

$$s = \frac{hk}{bk} = \frac{4,00}{2,50} = 1,6$$

$$\begin{aligned} b_o &= 2\{(bk+d) + (hk+d)\} \\ &= 2\{(2500+900) + (4000+900)\} \\ &= 16600 \text{ mm} \end{aligned}$$

b. Gaya geser yang ditahan beton ( $\phi V_c$ )

$$\begin{aligned} V_c &= \left( 1 + \frac{2}{\beta_c} \right) \frac{\sqrt{f'_c} b_o d}{6} \\ &= \left( 1 + \frac{2}{1,6} \right) \frac{\sqrt{20}.16600.900}{6} \\ &= 25055141,69 \text{ N} \\ &= 25055,14 \text{ kN} \end{aligned}$$

$$\begin{aligned} V_c &= \left( 2 + \frac{\alpha_s d}{b_o} \right) \frac{\sqrt{f'_c} b_o d}{12} \\ &= \left( 2 + \frac{30.900}{16600} \right) \frac{\sqrt{20}.16600.900}{12} \\ &= 20191693,84 \text{ N} \\ &= 20191,69 \text{ kN} \end{aligned}$$

$$\begin{aligned}
 V_c &= \left(\frac{1}{3}\right) \sqrt{f_c'} \cdot b_o \cdot d \\
 &= \left(\frac{1}{3}\right) \sqrt{20} \cdot 16600 \cdot 900 \\
 &= 22271237,1 \text{ N} \\
 &= 22271,24 \text{ kN}
 \end{aligned}$$

Dipilih gaya geser yang terkecil yaitu  $V_c = 20191,69 \text{ kN}$

Kontrol:  $V_u = 4995,04 \text{ kN} \leq \phi V_c = 0,75 \cdot 20191,69 \text{ kN}$

$V_u = 4995,04 \text{ kN} \leq \phi V_c = 15144 \text{ kN} \dots \text{OK}$

#### 4. Tulangan Pondasi

##### a. Tulangan arah x-x

$$\begin{aligned}
 x &= \frac{L}{2} - \frac{hk}{2} \\
 &= \frac{8,50}{2} - \frac{4,00}{2} \\
 &= 2,25 \text{ m}
 \end{aligned}$$

Menghitung  $\sigma_x$  = tegangan tanah pada jarak x

$$\begin{aligned}
 \sigma_x &= \sigma_{\min} + \frac{L-x}{L} (\sigma_{\max} - \sigma_{\min}) \\
 &= 46,76 + \frac{8,50-2,25}{8,50} (212,12 - 46,76) \\
 &= 168,35 \text{ kN/m}^2
 \end{aligned}$$

Momen yang terjadi ( $M_u$ )

$$\begin{aligned}
 M_u &= \frac{1}{2} \cdot \sigma_x \cdot x^2 + \frac{1}{3} (\sigma_{\max} - \sigma_x) x^2 \\
 &= \frac{1}{2} \cdot 168,35 \cdot 2,25^2 + \frac{1}{3} (212,12 - 168,35) 2,25^2 \\
 &= 499,99 \text{ kNm}
 \end{aligned}$$

Faktor momen pikul ( $K$ ) dan ( $K_{\max}$ )

$$\begin{aligned}
 K &= M_u / (\phi \cdot b \cdot d^2) \\
 &= 499,99 \cdot 10^6 / (0,80 \cdot 1000 \cdot 900^2) \\
 &= 0,772 \text{ Mpa}
 \end{aligned}$$

$$\begin{aligned}
 K_{\max} &= \frac{382,5 \cdot \beta_1 \cdot f_c' \cdot (600 + f_y - 225 \cdot \beta_1)}{(600 + f_y)^2} \\
 &= \frac{382,5 \cdot 0,85 \cdot 20 \cdot (600 + 240 - 225 \cdot 240)}{(600 + 240)^2} \\
 &= 5,979 \text{ Mpa}
 \end{aligned}$$

Tinggi blok tegangan beton tekan persegi ekuivalen (a)

$$a = \left(1 - \sqrt{1 - \frac{2K}{0,85 \cdot f_c'}}\right) d$$

$$= \left(1 - \sqrt{1 - \frac{2,0,772}{0,85,20}}\right) 900$$

$$= 41,82 \text{ mm}$$

Luas tulangan diperlukan ( $A_s,u$ )

$$A_{s,u} = \frac{0,85 \cdot f_c' \cdot a \cdot b}{f_y}$$

$$= \frac{0,85 \cdot 20 \cdot 41,82 \cdot 1000}{240}$$

$$= 2962,293 \text{ mm}^2$$

Tulangan yang digunakan

D19 – 75

$$A_s = 3780,38 \text{ mm}^2 > A_{s,u} = 2962,293 \text{ mm}^2$$

b. Tulangan arah y-y

$$x = \frac{B}{2} - \frac{bk}{2}$$

$$= \frac{6,50}{2} - \frac{2,50}{2}$$

$$= 2,00 \text{ m}$$

Momen yang terjadi ( $M_u$ )

$$M_u = \frac{1}{2} \cdot \sigma_{maks} \cdot x^2$$

$$= \frac{1}{2} \cdot 212,12 \cdot 2,00^2$$

$$= 424,24 \text{ kNm}$$

Faktor momen pikul ( $K$ ) dan ( $K_{maks}$ )

$$K = M_u / (\phi \cdot b \cdot d^2)$$

$$= 424,24 \cdot 10^6 / (0,80 \cdot 1000 \cdot 900^2)$$

$$= 0,655 \text{ Mpa}$$

$$K_{maks} = \frac{382,5 \cdot \beta_1 \cdot f_c' \cdot (600 + f_y - 225 \cdot \beta_1)}{(600 + f_y)^2}$$

$$= \frac{382,5 \cdot 0,85 \cdot 20 \cdot (600 + 240 - 225 \cdot 240)}{(600 + 240)^2} = 5,979 \text{ Mpa}$$

Tinggi blok tegangan beton tekan persegi ekuivalen ( $a$ )

$$a = \left(1 - \sqrt{1 - \frac{2K}{0,85 \cdot f_c'}}\right) d$$

$$= \left(1 - \sqrt{1 - \frac{2,0,655}{0,85,20}}\right) 900$$

$$= 35,35 \text{ mm}$$



Luas tulangan diperlukan ( $A_{s,u}$ )

$$\begin{aligned} A_{s,u} &= \frac{0,85 \cdot f_c' \cdot a \cdot b}{f_y} \\ &= \frac{0,85 \cdot 20,35 \cdot 35 \cdot 1000}{240} \\ &= 2504,25 \text{ mm}^2 \end{aligned}$$

Untuk jalur pusat selebar  $B = 6,50 \text{ m}$

$$\begin{aligned} A_{s,pusat} &= (2 \cdot B \cdot A_{s,u}) / (L + B) \\ &= (2 \cdot 6,50 \cdot 2504,25) / (8,50 + 6,50) \\ &= 2170,35 \text{ mm}^2 \end{aligned}$$

Tulangan yang digunakan

D19 – 125

$$A_s = 2268,23 \text{ mm}^2 > A_{s,u} = 2170,35 \text{ mm}^2$$

Untuk jalur tepi (diluar jalur pusat)

$$\begin{aligned} A_{s,tepi} &= A_{s,u} - A_{s,pusat} \\ &= 2504,25 - 2268,23 \\ &= 236,02 \text{ mm}^2 \end{aligned}$$

Tulangan yang digunakan

D19 – 450

$$A_s = 630,06 \text{ mm}^2 > A_{s,u} = 236,02 \text{ mm}^2$$

Detail Gambar Penulangan Pilar I dapat dilihat pada Gambar 4.46. sampai Gambar 4.43.

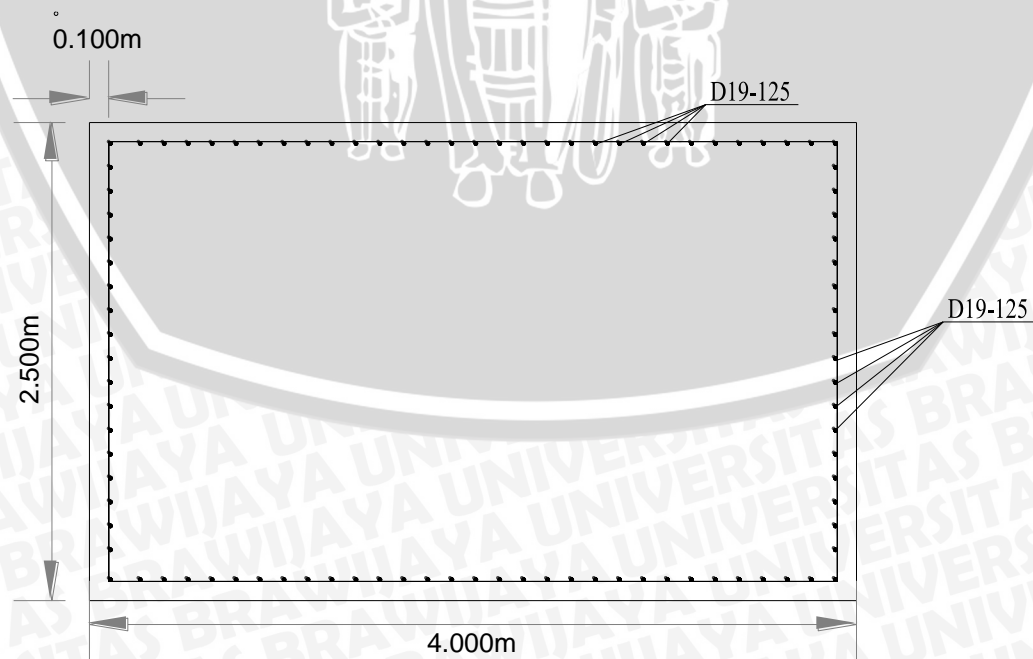

**Gambar 4.46. Tulangan Pilar I (Tampak Atas)**

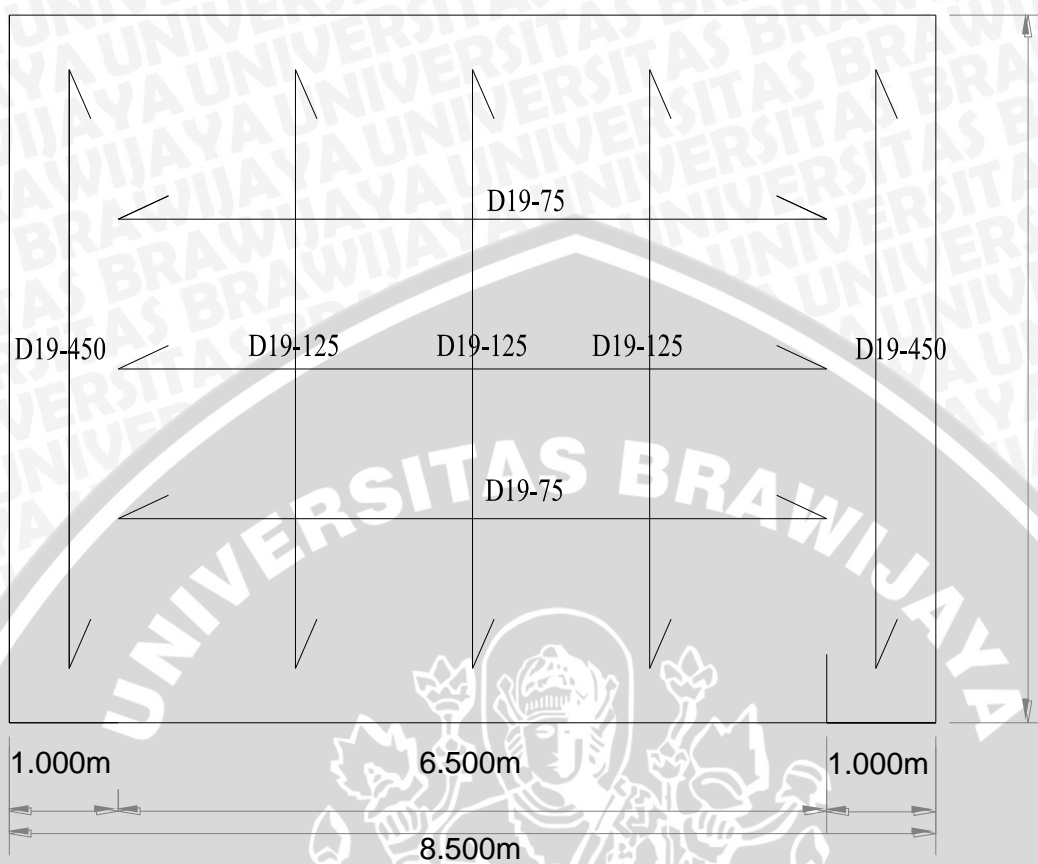

**Gambar 4.47. Pondasi Telapak Pilar I**

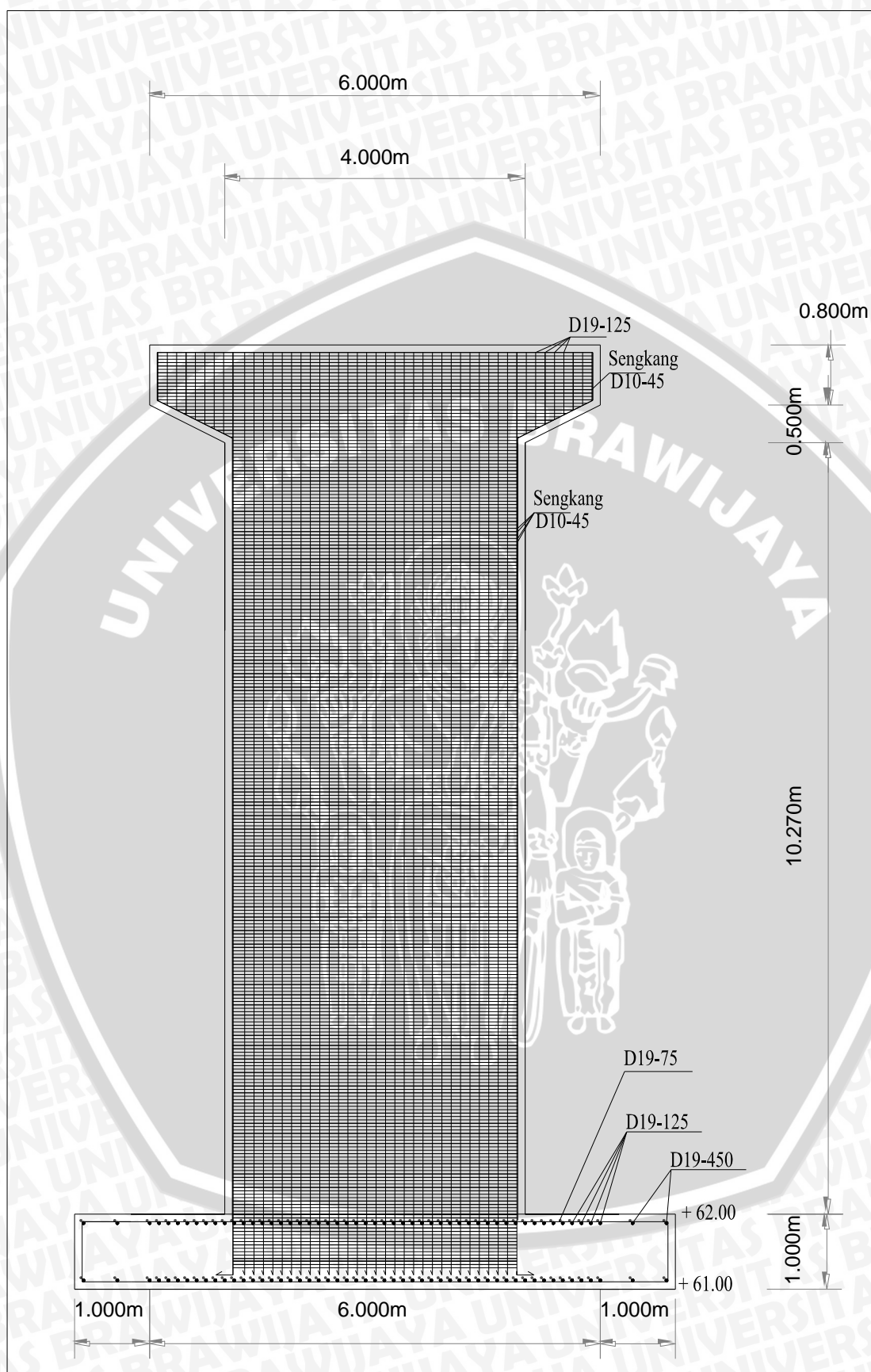

Gambar 4.48. Tulangan Pilar I

#### 4.5.1.2. Pilar II dan Pondasi Telapak

Perencanaan penulangan pada tubuh pilar berdasarkan luas penampang tubuh pilar serta momen lentur dan gaya tekan sentris akibat berat struktur di atasnya. Gaya dan momen lentur yang bekerja pada pilar dapat dilihat pada Tabel. 4.49 sedangkan gambar pilar dan diagram gaya yang bekerja pada pilar dapat dilihat pada Gambar 4.49 dan Gambar 4.50.

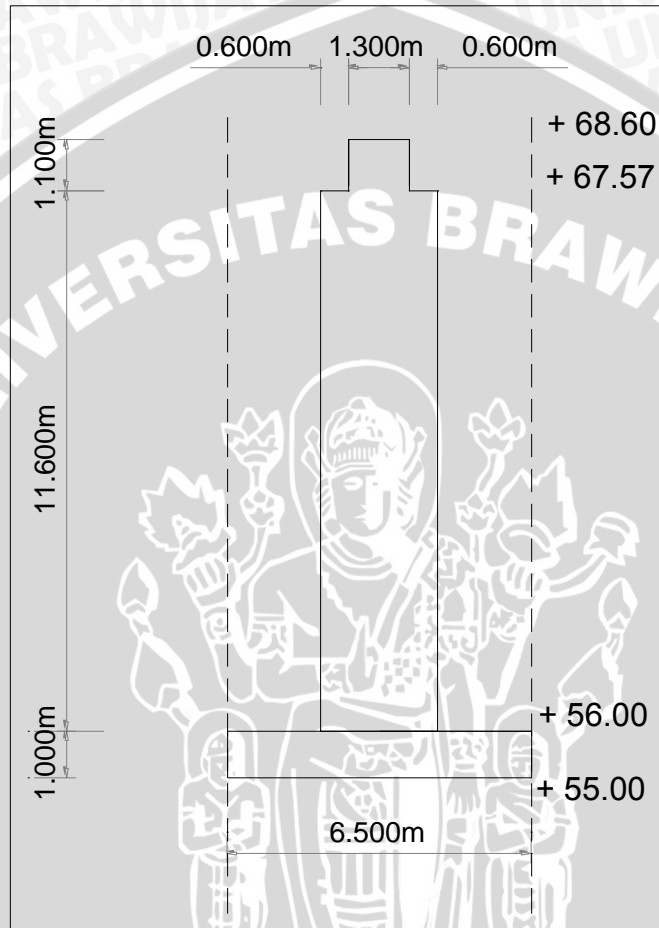

Gambar 4.49. Pilar II Kondisi Muka Air Banjir Gempa (Tampak Depan)

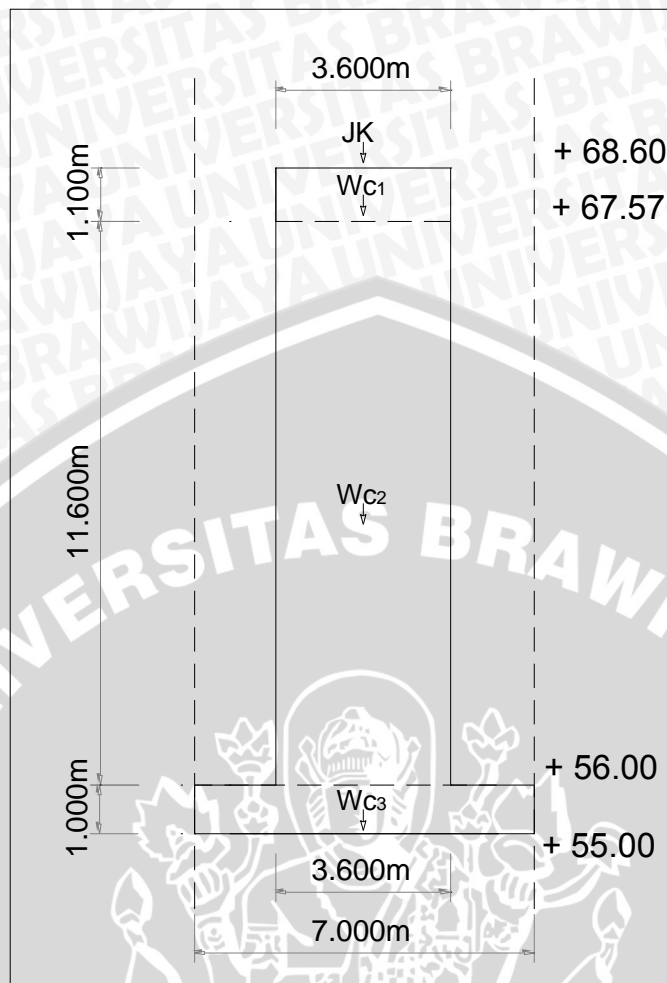

**Gambar 4.50. Diagram Gaya Pada Pilar II Kondisi Muka Air Banjir Gempa (Tampak Samping)**

**Tabel 4.49. Gaya dan Momen Pilar pada Jembatan Kendaraan Akibat Gempa**

Notasi	Nilai						Gaya		Lengan Momen	Momen				
	Lebar		Tinggi		Panjang		Ratio	$\gamma$		Pv	Ph	y	My	
	(m)		(m)		(m)			(t/m <sup>3</sup> )		(ton)	(ton)	(m)	(ton.m)	
	[1]		[2]		[3]		[4]		[5]		[6]	[7]	[8]	[9]
W <sub>JK</sub>										=	117,347	17,602	13,150	231,467
W <sub>c1</sub>	3,600	x	1,100	x	1,300	x	1,000	x	2,400	=	12,355	1,853	13,150	24,371
W <sub>c2</sub>	3,600	x	11,600	x	2,500	x	1,000	x	2,400	=	250,560	37,584	6,800	255,571
Total									$\Sigma V$		380,262		$\Sigma Mh$	511,409
									$\Sigma H$			57,039		

Sumber: Hasil Perhitungan

$P_u = 1,200 \times \Sigma V$ $= 1,200 \times 380,262$ $= 456,315 \text{ ton}$	$M_u = 1,200 \times \Sigma Mh$ $= 1,200 \times 511,409$ $= 613,691 \text{ ton}$
--	---

Keterangan:

- [ 1 ] = lebar tiap bagian (m)  
 [ 2 ] = tinggi tiap bagian (m)  
 [ 3 ] = panjang konstruksi  
 [ 4 ] = 1 digunakan untuk penampang persegi atau persegi panjang  
 = 0,5 digunakan untuk penampang segitiga  
 [ 5 ] = berat jenis beton bertulang = 2,4 (t/m<sup>3</sup>)  
 = berat jenis air = 1,0 (t/m<sup>3</sup>)  
 [ 6 ] = gaya vertikal (ton)  
 = [ 1 ] \* [ 2 ] \* [ 3 ] \* [ 4 ] \* [ 5 ] (untuk bangunan dan timbunan )  
 nilai (+) untuk arah gaya ke bawah  
 nilai (-) untuk arah gaya ke atas  
 [ 7 ] = gaya horizontal (ton)  
 = [ 6 ] \* kh , dengan kh = 0,15 (untuk berat bangunan)  
 = 7/12 \* [ 1 ] \* [ 2 ] \* [ 3 ] \* [ 4 ] \* [ 5 ] \* kh (untuk tekanan air dinamis)  
 nilai (+) untuk arah gaya ke hilir  
 nilai (-) untuk arah gaya ke hulu  
 [ 8 ] = lengan momen gaya berat konstruksi (m)  
 [ 9 ] = momen (ton.m)  
 = [ 7 ] \* [ 8 ]

Data Pilar I :

1. Lebar (h) = 3,60 m
2. Tebal (b) = 2,50 m
3. Tinggi = 12,70m
4. Mutu Bahan
  - Beton ( $f_c'$ ) = 20,00 Mpa
  - Baja ( $f_y$ ) = 240,00 Mpa
5. Beban pada Pilar
  - c.  $P_u$  = 4563,15 kN
  - d.  $M_u$  = 6136,91 kN.m

a. Kontrol Kelangsingan

Pilar diasumsikan sebagai kolom tanpa pengaku, dibagian atas dan bawahnya jepit-jepit, maka  $k = 1,00$  (Tabel 2.7). Kelangsingan kolom dapat dihitung menggunakan persamaan (2-94) dan persamaan (2-95) sebagai berikut:

dimana:

$$\begin{aligned} A &= b \cdot h \\ &= 2,5 \times 3,6 \\ &= 9,00 \text{ m}^2 \end{aligned}$$

$$\begin{aligned} I &= \frac{1}{12} \cdot b \cdot h^3 \\ &= \frac{1}{12} \cdot 2,5 \cdot (3,6)^3 \\ &= 9,720 \text{ m}^4 \end{aligned}$$

$$\begin{aligned} r &= \sqrt{\frac{I}{A}} \\ &= \sqrt{\frac{9,720}{10,00}} = 1,039 \text{ m} \end{aligned}$$

$$k \frac{\lambda_{n,k}}{r} < 22$$

$$1,0 \frac{12,70}{1,039} < 22$$

$$12,221 < 22 \text{ (Termasuk Kolom Pendek)}$$

b. Luas Penampang Pilar

$$\begin{aligned} A_{gr} &= \text{Lebar} \times \text{Tebal} \\ &= 3,60 \times 2,50 \\ &= 9,00 \text{ m}^2 \\ &= 9 \cdot 10^6 \text{ mm}^2 \end{aligned}$$



## c. Tulangan Kolom

Pada sumbu vertikal

$$\frac{P_u}{\phi \cdot A_{gr} \cdot 0,85 \cdot f_c'} = \frac{4563,15 \cdot 10^3}{0,65 \cdot 9 \cdot 10^6 \cdot 0,85 \cdot 20,00}$$

$$= 0,046 < 0,10$$

$\phi$  ditingkatkan menjadi 0,80 maka:

$$\frac{P_u}{\phi \cdot A_{gr} \cdot 0,85 \cdot f_c'} = \frac{4563,15 \cdot 10^3}{0,80 \cdot 10^7 \cdot 0,85 \cdot 20,00}$$

$$= 0,037 < 0,10$$

$$e_t = \frac{M_u}{P_u}$$

$$= \frac{6136,91}{4563,15}$$

$$= 1,345 \text{ m}$$

$$e_t/h = 1344,88/3600 = 0,37$$

Pada sumbu horizontal

$$\frac{P_u}{\phi \cdot A_{gr} \cdot 0,85 \cdot f_c'} \left( \frac{e_t}{h} \right) = 0,037 \cdot 0,37$$

$$= 0,0139$$

Dengan  $d'/h = 1000/3600 = 0,03$  diambil  $d'/h = 0,10$

Berdasarkan grafik pada Gambar 2.14, maka diperoleh  $r = 0,004$  dan  $\beta = 0,80$

$$\rho = \beta \cdot r$$

$$= 0,80 \cdot 0,004$$

$$= 0,0032$$

$$A_{g \text{ total}} = \rho \cdot A_{gr}$$

$$= 0,0032 \cdot 9 \cdot 10^6$$

$$= 28800 \text{ mm}^2$$

$$= 288 \text{ cm}^2$$

Dipakai: Tulangan utama 114 D 19-100  $\text{mm}^2 = 32322,3 \text{ mm}^2 > 28800 \text{ mm}^2$

## d. Begel pada Kolom

Tebal selimut beton (ds) = 100 mm

$$d = h - ds$$

$$= 3600 - 100$$

$$= 3500 \text{ mm}$$



1. Gaya geser perlu kolom ( $V_{u,k}$ )

$$\begin{aligned} V_{u,k} &= \frac{Mu_2 - Mu_1}{\lambda_k} \\ &= \frac{6136,91}{12,70} \\ &= 483,22 \text{ kN} \\ &= 483220,90 \text{ N} \end{aligned}$$

2. Gaya geser yang ditahan oleh beton ( $V_c$ )

$$\begin{aligned} V_c &= \left(1 + \frac{Nu_k}{14.A_g}\right) \frac{\sqrt{f'_c}}{6} . b.d \\ &= \left(1 + \frac{4563,15}{14.2500.3600}\right) \frac{\sqrt{20}}{6} . 2500.3500 \\ &= 6758057,192 \text{ N} \end{aligned}$$

3. Gaya geser yang ditahan oleh beton ( $V_s$ ) dan  $V_{s,maks}$ 

$$\begin{aligned} V_s &= \frac{V_u - \phi . V_c}{\phi} \text{ dengan } \phi = 0,75 \\ &= \frac{483220,90 - 0,75.6758057,192}{0,75} \text{ dengan } \phi = 0,75 \\ &= -6113762,654 \text{ N} \end{aligned}$$

$$\begin{aligned} V_{s,max} &= \frac{2}{3} . \sqrt{f'_c} . b.d \\ &= \frac{2}{3} . \sqrt{20} . 2500.3500 \\ &= 26087459,74 \text{ N} , \text{ syarat } V_s \leq V_{s,maks} \dots \text{ OK} \end{aligned}$$

4. Luas begel perlu ( $A_{v,u}$ ) untuk setiap panjang kolom  $S = 1000 \text{ mm}$ , dengan memilih yang terbesar dari nilai  $A_v$  berikut:

$$\begin{aligned} A_v &= \frac{V_s . S}{f_y . d} \\ &= \frac{-6113762654 . 1000}{240.3500} \\ &= -7278,29 \text{ mm}^2 \end{aligned}$$

$$\begin{aligned} A_v &= \frac{b . S}{3 . f_y} \\ &= \frac{2500.1000}{3.240} = 3472,2 \text{ mm}^2 \end{aligned}$$

$$\begin{aligned} A_v &= \frac{75\sqrt{f'_c} . b . S}{1200 . f_y} \\ &= \frac{75\sqrt{20} . 2500 . 1000}{1200.240} \\ &= 2911,55 \text{ mm}^2 \end{aligned}$$

Dipilih yang paling besar, jadi  $A_{v,u} = 3472,2 \text{ mm}^2$

Digunakan begel 2 kaki dengan  $d_p = 10 \text{ mm}$

## 5. Jarak antar begel

$$s = \frac{\frac{n}{4} \pi \cdot d_p^2 \cdot S}{A_{v,u}}$$

$$= \frac{\frac{2}{4} \pi \cdot 10^2 \cdot 1000}{3472,2}$$

$$= 45,24 \text{ mm}$$

Kontrol jarak:

$$s \leq 16D = 304 \text{ mm}$$

$$s \leq 48 \cdot d_p = 480 \text{ mm}$$

$$s \leq d/2 = 1750 \text{ mm}$$

$$s \leq 600 \text{ mm}$$

Dipakai nilai terkecil dan dibulatkan ke bawah, yaitu  $s = 45 \text{ mm} \leq 45,24 \text{ mm}$

(Dibaca: "Begel 2 kaki berdiameter polos 10 mm dan berjarak 45 mm")

## e. Telapak Pondasi

Gaya dan momen yang bekerja pada pondasi telapak dapat dilihat pada Tabel. 4.50.

**Tabel 4.50. Gaya dan Momen Pondasi Telapak Akibat Gempa**

Notasi	Nilai						Gaya		Lengan Momen	Momen
	Lebar	Tinggi	Panjang	Ratio	$\gamma$	Pv	Ph	y	My	
	(m)	(m)	(m)		(t/m <sup>3</sup> )	(ton)	(ton)	(m)	(ton.m)	
	[1]	[2]	[3]	[4]	[5]	[6]	[7]	[8]	[9]	
W <sub>JK</sub>						= 117,347	17,602	13,150	231,467	
W <sub>c1</sub>	3,600 x	1,100 x	1,300 x	1,000 x	2,400	= 12,355	1,853	13,150	24,371	
W <sub>c2</sub>	3,600 x	11,600 x	2,500 x	1,000 x	2,400	= 250,560	37,584	6,800	255,571	
W <sub>c3</sub>	7,000 x	1,000 x	6,500 x	1,000 x	2,400	= 109,200	16,380	0,500	8,190	
Total						$\Sigma V$	489,462			
						$\Sigma H$		73,419		
								$\Sigma Mh$	519,599	

Sumber: Hasil Perhitungan

Pu	=	1,200 x	$\Sigma V$	Mu	=	1,200 x	$\Sigma Mh$
	=	1,200 x	489,462		=	1,200 x	519,599
	=	587,355 ton			=	623,519 ton	

Keterangan:

[ 1 ] = lebar tiap bagian (m)

[ 2 ] = tinggi tiap bagian (m)

[ 3 ] = panjang konstruksi

[ 4 ] = 1 digunakan untuk penampang persegi atau persegi panjang

= 0,5 digunakan untuk penampang segitiga

[ 5 ] = berat jenis beton bertulang = 2,4 (t/m<sup>3</sup>)

= berat jenis air = 1,0 (t/m<sup>3</sup>)

[ 6 ] = gaya vertikal (ton)

= [ 1 ] \* [ 2 ] \* [ 3 ] \* [ 4 ] \* [ 5 ] (untuk bangunan dan timbunan )

nilai (+) untuk arah gaya ke bawah

nilai (-) untuk arah gaya ke atas

[ 7 ] = gaya horizontal (ton)

= [ 6 ] \* kh , dengan kh = 0,15 (untuk berat bangunan)

= 7/12 \* [ 1 ] \* [ 2 ] \* [ 3 ] \* [ 4 ] \* [ 5 ] \* kh (untuk tekanan air dinamis)

nilai (+) untuk arah gaya ke hilir

nilai (-) untuk arah gaya ke hulu

[ 8 ] = lengan momen gaya berat konstruksi (m)

[ 9 ] = momen (ton.m)

= [ 7 ] \* [ 8 ]

Data pondasi telapak:

1. Lebar (B) = 6,50 m
2. Panjang (L) = 8,50 m
3. Tebal (h) = 1,00 m
4. Panjang Kolom (hk) = 3,60 m
5. Lebar Kolom (bk) = 2,50 m
6. Tebal Selimut (ds) = 0,10 m
7. Mutu Bahan
  - Beton (fc') = 20,00 Mpa
  - Baja (fy) = 240 Mpa
8. Beban pada Pondasi Telapak
  - Pu = 5873,55 kN
  - Mu = 6235,19 kNm

Langkah perhitungan pondasi telapak adalah sebagai berikut:

1. Menghitung tegangan

$$\sigma_{\max,\min} = \frac{P_{u,k}}{B.L} \pm \frac{M_{u,x}}{\frac{1}{6}.B.L^2}$$

$$= \frac{5873,55}{6,50.7,00} \pm \frac{6235,19}{\frac{1}{6}.6,5.7,0^2}$$

$$\sigma_{\max} = 129,09 + 117,46$$

$$= 246,55 \text{ kN/m}^2$$

$$\sigma_{\min} = 129,09 - 117,46$$

$$= 11,63 \text{ kN/m}^2$$

## 2. Kontrol Tegangan Geser 1 Arah

$$d_s = 100 \text{ mm}$$

$$\begin{aligned} d &= h - d_s \\ &= 1000 - 100 \\ &= 900 \text{ mm} \end{aligned}$$

$$\begin{aligned} a &= \frac{L}{2} - \frac{hk}{2} - d \\ &= \frac{7000}{2} - \frac{3600}{2} - 900 = 800 \text{ mm} = 0,80 \text{ m} \end{aligned}$$

$$\begin{aligned} \sigma_a &= \sigma_{\min} + \frac{(L-a) \cdot (\sigma_{\max} - \sigma_{\min})}{L} \\ &= 11,63 + \frac{(7000-800) \cdot (246,55-11,63)}{7000} = 219,70 \text{ kN/mm}^2 \end{aligned}$$

Gaya tekan ke atas ( $V_u$ )

$$\begin{aligned} V_u &= a \cdot B \left( \frac{\sigma_{\max} + \sigma_a}{2} \right) \\ &= 0,80 \cdot 6,5 \left( \frac{246,55 + 219,70}{2} \right) \\ &= 1212,25 \text{ kN} \end{aligned}$$

Gaya geser yang dapat ditahan oleh beton ( $\phi V_c$ ) dengan  $\phi = 0,75$

$$\begin{aligned} V_c &= \frac{\sqrt{f'_c}}{6} B d \phi \\ &= \frac{\sqrt{20}}{6} 6500 \cdot 900 \cdot 0,75 \\ &= 3270,25 \text{ kN} \end{aligned}$$

Kontrol  $V_u = 1212,25 \text{ kN} \leq \phi \cdot V_c = 3270,25 \text{ kN} \dots \text{OK}$

## 3. Kontrol Tegangan Geser 2 Arah (Geser Pons)

$$(b + d) = (2500 + 900) = 3400 \text{ mm} = 3,40 \text{ m}$$

$$(h + d) = (3600 + 900) = 4500 \text{ mm} = 4,50 \text{ m}$$

a. Gaya Tekan ke atas (Geser Pons)

$$\begin{aligned} V_u &= \{B \cdot L - (b+d)(h+d)\} \left( \frac{\sigma_{\max} + \sigma_{\min}}{L} \right) \\ &= \{7000 \cdot 6500 - 3400 \cdot 4500\} \left( \frac{246,55 + 11,63}{7000} \right) \end{aligned}$$

$$= 3898,49 \text{ kN}$$

$$s = \frac{hk}{bk} = \frac{3,60}{2,50} = 1,44$$

$$\begin{aligned} b_o &= 2\{(bk+d) + (hk+d)\} \\ &= 2\{(2500+900) + (3600+900)\} \\ &= 15800 \text{ mm} \end{aligned}$$

b. Gaya geser yang ditahan beton ( $\phi V_c$ )

$$\begin{aligned} V_c &= \left(1 + \frac{2}{\beta_c}\right) \frac{\sqrt{f_c'} b_o d}{6} \\ &= \left(1 + \frac{2}{1,44}\right) \frac{\sqrt{20} \cdot 15800 \cdot 900}{6} \\ &= 25319743,07 \text{ N} \\ &= 25319,74 \text{ kN} \end{aligned}$$

$$\begin{aligned} V_c &= \left(2 + \frac{\alpha_s d}{b_o}\right) \frac{\sqrt{f_c'} b_o d}{12} \\ &= \left(2 + \frac{30 \cdot 900}{15800}\right) \frac{\sqrt{20} \cdot 15800 \cdot 900}{12} \\ &= 19655037,52 \text{ N} \\ &= 19655,04 \text{ kN} \end{aligned}$$

$$\begin{aligned} V_c &= \left(\frac{1}{3}\right) \sqrt{f_c'} \cdot b_o d \\ &= \left(\frac{1}{3}\right) \sqrt{20} \cdot 15800 \cdot 900 \text{ N} \\ &= 21197924,4 \text{ N} \\ &= 21297,92 \text{ kN} \end{aligned}$$

Dipilih gaya geser yang terkecil yaitu  $V_c = 19655,04 \text{ kN}$

Kontrol:  $V_u = 4928,92 \text{ kN} \leq \phi V_c = 0,75 \cdot 19655,04 \text{ kN}$

$V_u = 4928,92 \text{ kN} \leq \phi V_c = 14741 \text{ kN} \dots \text{OK}$

4. Tulangan Pondasi

a. Tulangan arah x-x

$$\begin{aligned} x &= \frac{L}{2} - \frac{hk}{2} \\ &= \frac{7,00}{2} - \frac{3,60}{2} = 1,70 \text{ m} \end{aligned}$$

Menghitung  $\sigma_x$  = tegangan tanah pada jarak x

$$\begin{aligned} \sigma_x &= \sigma_{\min} + \frac{L-x}{L} (\sigma_{\max} - \sigma_{\min}) \\ &= 129,09 + \frac{7,00-1,70}{7,00} (246,55 - 11,63) \\ &= 189,50 \text{ kN/m}^2 \end{aligned}$$

Momen yang terjadi ( $M_u$ )

$$\begin{aligned} M_u &= \frac{1}{2} \cdot \sigma_x \cdot x^2 + \frac{1}{3} (\sigma_{\max} - \sigma_x) x^3 \\ &= \frac{1}{2} \cdot 189,50 \cdot 1,70^2 + \frac{1}{3} (246,55 - 189,50) 1,70^3 \\ &= 328,78 \text{ kNm} \end{aligned}$$

Faktor momen pikul (K) dan (Kmaks)

$$\begin{aligned} K &= Mu/(\phi \cdot b \cdot d^2) \\ &= 328,78 \cdot 10^6 / (0,80 \cdot 1000 \cdot 900^2) \\ &= 0,507 \text{ Mpa} \end{aligned}$$

$$\begin{aligned} K_{\max} &= \frac{382,5 \cdot \beta_1 \cdot f_c' \cdot (600 + f_y - 225 \cdot \beta_1)}{(600 + f_y)^2} \\ &= \frac{382,5 \cdot 0,85 \cdot 20 \cdot (600 + 240 - 225 \cdot 240)}{(600 + 240)^2} \\ &= 5,979 \text{ Mpa} \end{aligned}$$

Tinggi blok tegangan beton tekan persegi ekuivalen (a)

$$\begin{aligned} a &= \left( 1 - \sqrt{1 - \frac{2K}{0,85 \cdot f_c'}} \right) d \\ &= \left( 1 - \sqrt{1 - \frac{2 \cdot 0,507}{0,85 \cdot 20}} \right) 900 \\ &= 27,27 \text{ mm} \end{aligned}$$

Luas tulangan diperlukan (As,u)

$$\begin{aligned} A_{s,u} &= \frac{0,85 \cdot f_c' \cdot a \cdot b}{f_y} \\ &= \frac{0,85 \cdot 20 \cdot 27,27 \cdot 1000}{240} \\ &= 1931,957 \text{ mm}^2 \end{aligned}$$

Tulangan yang digunakan

D19 – 125

$$A_s = 2268,23 \text{ mm}^2 > A_{s,u} = 1931,957 \text{ mm}^2$$

b. Tulangan arah y-y

$$\begin{aligned} x &= \frac{B}{2} - \frac{b_k}{2} \\ &= \frac{6,50}{2} - \frac{2,50}{2} \\ &= 2,00 \text{ m} \end{aligned}$$

Momen yang terjadi (Mu)

$$\begin{aligned} Mu &= \frac{1}{2} \cdot \sigma_{\max} \cdot x^2 \\ &= \frac{1}{2} \cdot 246,55 \cdot 2,00^2 \\ &= 493,10 \text{ kNm} \end{aligned}$$

Faktor momen pikul (K) dan (Kmaks)

$$\begin{aligned} K &= Mu/(\phi \cdot b \cdot d^2) \\ &= 493,10 \cdot 10^6 / (0,80 \cdot 1000 \cdot 900^2) = 0,761 \text{ Mpa} \end{aligned}$$

$$\begin{aligned}
 K_{\max} &= \frac{382,5 \cdot \beta_1 \cdot f_c' \cdot (600 + f_y - 225 \cdot \beta_1)}{(600 + f_y)^2} \\
 &= \frac{382,5 \cdot 0,85 \cdot 20 \cdot (600 + 240 - 225 \cdot 240)}{(600 + 240)^2} = 5,979 \text{ Mpa}
 \end{aligned}$$

Tinggi blok tegangan beton tekan persegi ekuivalen (a)

$$\begin{aligned}
 a &= \left( 1 - \sqrt{1 - \frac{2K}{0,85 \cdot f_c'}} \right) d \\
 &= \left( 1 - \sqrt{1 - \frac{2 \cdot 0,761}{0,85 \cdot 20}} \right) 900 \\
 &= 41,23 \text{ mm}
 \end{aligned}$$

Luas tulangan diperlukan ( $A_{s,u}$ )

$$\begin{aligned}
 A_{s,u} &= \frac{0,85 \cdot f_c' \cdot a \cdot b}{f_y} \\
 &= \frac{0,85 \cdot 20 \cdot 41,23 \cdot 1000}{240} \\
 &= 2920,47 \text{ mm}^2
 \end{aligned}$$

Untuk jalur pusat selebar  $B = 6,50 \text{ m}$

$$\begin{aligned}
 A_{s,\text{pusat}} &= (2 \cdot B \cdot A_{s,u}) / (L + B) \\
 &= (2 \cdot 6,50 \cdot 2920,47) / (7,00 + 6,50) \\
 &= 2812,31 \text{ mm}^2
 \end{aligned}$$

Tulangan yang digunakan

$$D19 - 100$$

$$A_s = 2835,29 \text{ mm}^2 > A_{s,u} = 2812,31 \text{ mm}^2$$

Untuk jalur tepi (diluar jalur pusat)

$$\begin{aligned}
 A_{s,\text{tepi}} &= A_{s,u} - A_{s,\text{pusat}} \\
 &= 2920,47 - 2835,29 \\
 &= 85,19 \text{ mm}^2
 \end{aligned}$$

Tulangan yang digunakan

$$D19 - 450$$

$$A_s = 630,06 \text{ mm}^2 > A_{s,u} = 85,19 \text{ mm}^2$$

Detail Gambar Penulangan Pilar II dapat dilihat pada Gambar 4.51 sampai Gambar 4.53.

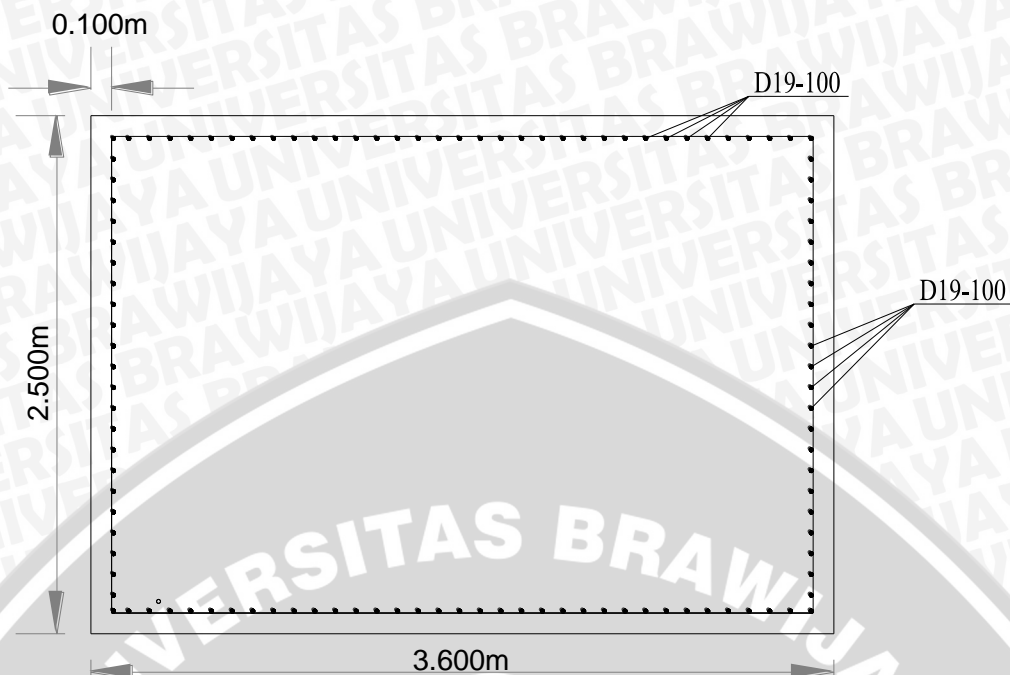

**Gambar 4.51. Tulangan Beton Pilar II (Tampak Atas)**

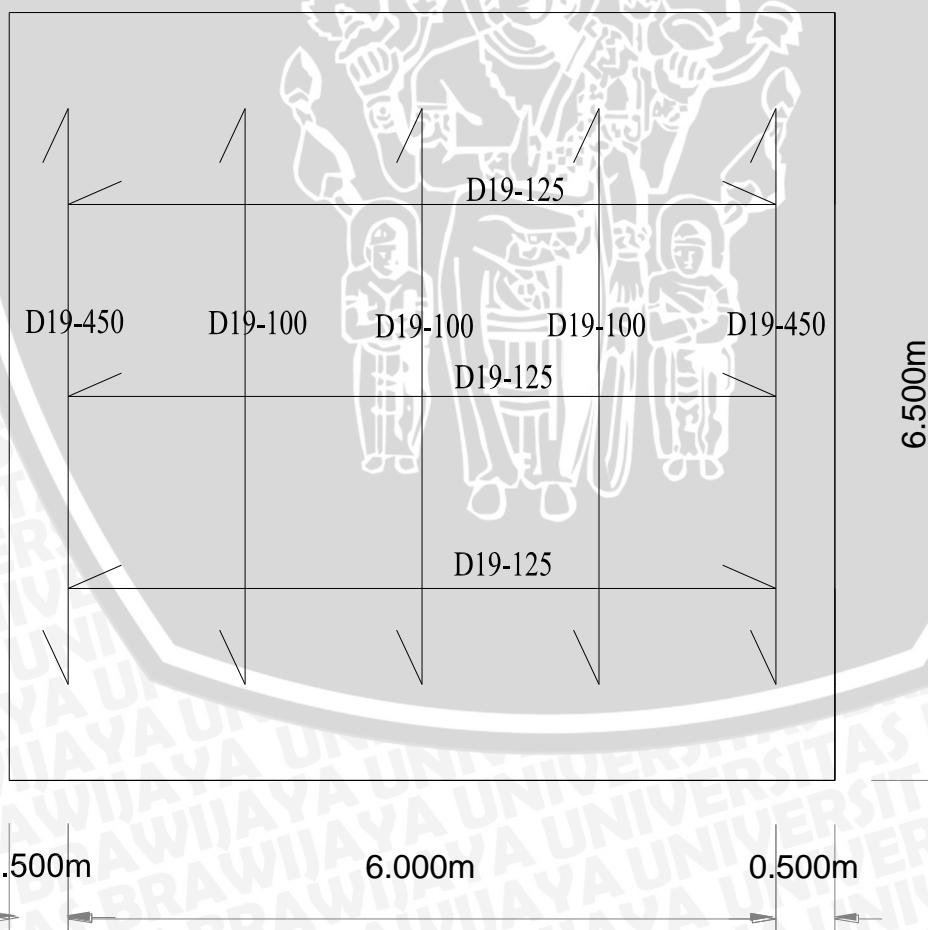

**Gambar 4.52. Pondasi Telapak Pilar II**



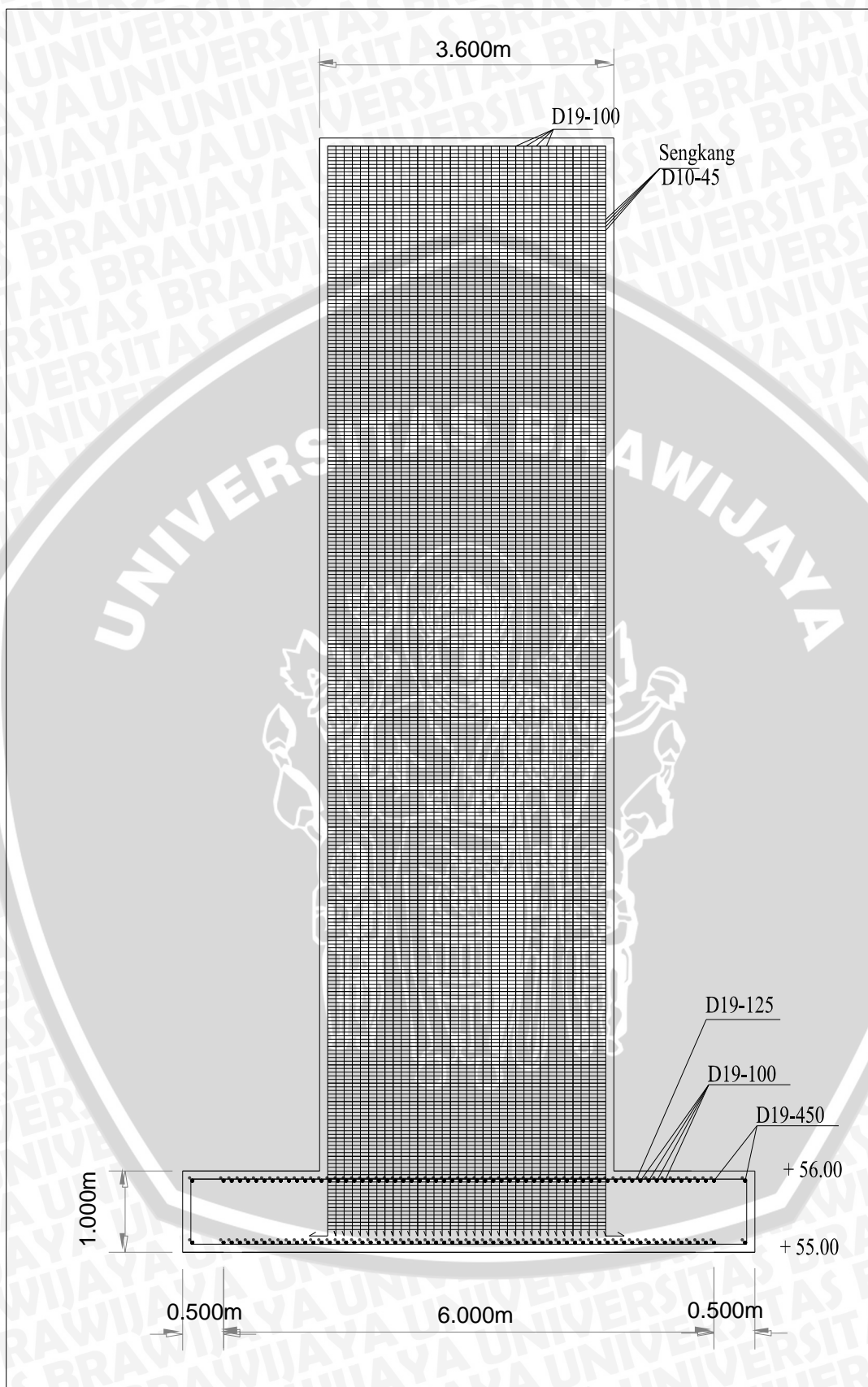

Gambar 4.53. Tulangan Pilar II

#### 4.5.1.3. Pilar III, Pilar IV dan Pilar V

Perencanaan penulangan pada tubuh pilar berdasarkan luas penampang tubuh pilar serta momen lentur dan gaya tekan sentris akibat berat struktur di atasnya. Gambar diagram gaya yang bekerja pada pilar dapat dilihat pada Gambar 4.54.

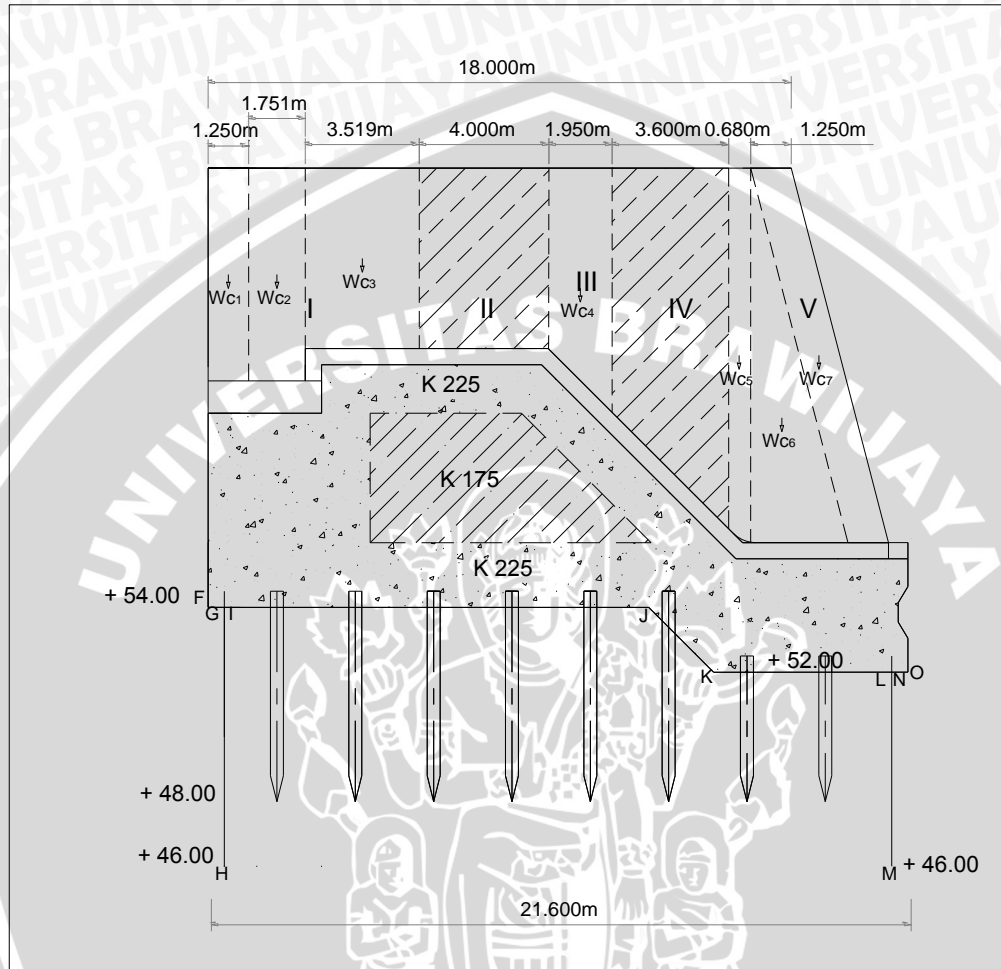

Gambar 4.54. Diagram Gaya Pada Pilar

Keterangan:

- I = Pilar III
- II = Pilar I (menahan beban rumah operasi pintu dan jembatan kendaraan)
- III = Pilar IV
- IV = Pilar II (menahan beban jembatan kendaraan)
- V = Pilar V

#### 4.4.1.3.1. Pilar III

Perencanaan tulangan pada pilar ini menggunakan tulangan praktis yang berfungsi untuk menghindari keretakan pilar akibat susut beton. Pilar ini hanya menahan beban sendiri dikarenakan beban rumah operasional pintu, jembatan

pelayanan dan jembatan kendaraan sudah dibebankan seluruhnya pada pilar I dan pilar II. Perhitungan gaya dan momen pilar dapat dilihat pada Tabel 4.51.

**Tabel 4.51. Gaya dan Momen Pilar III**

Notasi	Nilai					Gaya		Lengan Momen	Momen							
	Lebar (m)	Tinggi (m)	Panjang (m)	Ratio	$\gamma$ (t/m <sup>3</sup> )	Pv (ton)	Ph (ton)	y (m)	My (ton.m)							
	[1]	[2]	[3]	[4]	[5]	[6]	[7]	[8]	[9]							
Wc1	1,250	x	6,570	x	2,500	x	0,500	x	2,400	x	$\pi$	=	77,401	11,610	4,286	49,761
Wc2	1,751	x	6,570	x	2,500	x	1,000	x	2,400			=	69,024	10,354	4,286	44,376
Wc3	3,499	x	5,573	x	2,500	x	1,000	x	2,400				117,000	17,550	4,786	83,994
Total						$\Sigma V$							263,425		$\Sigma Mh$	94,137
					$\Sigma H$									21,964		

Sumber: Hasil Perhitungan

$Pu = 1,200 \times \Sigma V$ $= 1,200 \times 263,425$ $= 316,11 \text{ ton}$	$Mu = 1,200 \times \Sigma Mh$ $= 1,200 \times 94,137$ $= 112,964 \text{ ton}$
--	---

Keterangan:

- [ 1 ] = lebar tiap bagian (m)  
 [ 2 ] = tinggi tiap bagian (m)  
 [ 3 ] = panjang konstruksi  
 [ 4 ] = 1 digunakan untuk penampang persegi atau persegi panjang  
 = 0,5 digunakan untuk penampang segitiga  
 [ 5 ] = berat jenis beton bertulang = 2,4 (t/m<sup>3</sup>)  
 = berat jenis air = 1,0 (t/m<sup>3</sup>)  
 [ 6 ] = gaya vertikal (ton)  
 = [ 1 ] \* [ 2 ] \* [ 3 ] \* [ 4 ] \* [ 5 ] (untuk bangunan dan timbunan )  
 nilai (+) untuk arah gaya ke bawah  
 nilai (-) untuk arah gaya ke atas  
 [ 7 ] = gaya horizontal (ton)  
 = [ 6 ] \* kh , dengan kh = 0,15 (untuk berat bangunan)  
 = 7/12 \* [ 1 ] \* [ 2 ] \* [ 3 ] \* [ 4 ] \* [ 5 ] \* kh (untuk tekanan air dinamis)  
 nilai (+) untuk arah gaya ke hilir  
 nilai (-) untuk arah gaya ke hulu  
 [ 8 ] = lengan momen gaya berat konstruksi (m)  
 [ 9 ] = momen (ton.m)  
 = [ 7 ] \* [ 8 ]

Data Pilar III :

1. Lebar (h) = 6,50 m
2. Tebal (b) = 2,50 m
3. Tinggi = 6,57 m
4. Mutu Bahan
  - Beton ( $f_c'$ ) = 20,00 Mpa
  - Baja ( $f_y$ ) = 240,00 Mpa
5. Beban pada Pilar
  - a.  $P_u$  = 3161,0 kN
  - b.  $M_u$  = 1129,64 kN.m

a. Kontrol Kelangsingan

Pilar diasumsikan sebagai kolom tanpa pengaku, dibagian atas dan bawahnya jepit-jepit, maka  $k = 1,00$  (Tabel 2.7). Kelangsingan kolom dapat dihitung menggunakan persamaan (2-94) dan persamaan (2-95) sebagai berikut:

dimana:

$$\begin{aligned} A &= (\text{Lebar} \times \text{tebal}) + (1/2 \cdot \pi \cdot r^2) \\ &= (2,5 \times 3,6) + (1/2 \cdot \pi \cdot 1,25^2) \\ &= 15,579 \text{ m}^2 \end{aligned}$$

$$\begin{aligned} I &= \frac{1}{12} \cdot b \cdot h^3 \\ &= \frac{1}{12} \cdot 2,5 \cdot (6,5)^3 \\ &= 57,214 \text{ m}^4 \end{aligned}$$

$$\begin{aligned} r &= \sqrt{\frac{I}{A}} \\ &= \sqrt{\frac{57,214}{10,00}} = 1,876 \text{ m} \end{aligned}$$

$$k \frac{\lambda_{n,k}}{r} < 22$$

$$1,0 \frac{6,57}{1,876} < 22$$

$$3,50 < 22 \text{ (Termasuk Kolom Pendek)}$$

b. Luas Penampang Pilar

$$\begin{aligned} A_{gr} &= \text{Lebar} \times \text{tebal} + (1/2 \cdot \pi \cdot r^2) \\ &= (2,5 \times 3,6) + (1/2 \cdot \pi \cdot 1,25^2) \\ &= 15,579 \text{ m}^2 = 1,6 \cdot 10^7 \text{ mm}^2 \end{aligned}$$

## c. Tulangan Kolom

Pada sumbu vertikal

$$\frac{P_u}{\phi \cdot A_{gr} \cdot 0,85 \cdot f_c'} = \frac{3161,10 \cdot 10^3}{0,65 \cdot 1,5 \cdot 10^7 \cdot 0,85 \cdot 20,00}$$

$$= 0,018 < 0,10$$

Ø ditingkatkan menjadi 0,80 maka:

$$\frac{P_u}{\phi \cdot A_{gr} \cdot 0,85 \cdot f_c'} = \frac{3161,10 \cdot 10^3}{0,65 \cdot 1,5 \cdot 10^7 \cdot 0,85 \cdot 20,00}$$

$$= 0,015 < 0,10$$

$$e_t = \frac{M_u}{P_u}$$

$$= \frac{1129,64}{3161,64}$$

$$= 0,357 \text{ m}$$

$$e_t/h = 357,36/6500 = 0,05$$

Pada sumbu horizontal

$$\frac{P_u}{\phi \cdot A_{gr} \cdot 0,85 \cdot f_c'} \left( \frac{e_t}{h} \right) = 0,015 \cdot 0,05$$

$$= 0,00082$$

Dengan  $d'/h = 100/6500 = 0,03$  diambil  $d'/h = 0,02$

Berdasarkan grafik pada Gambar 2.14, maka diperoleh  $r = 0,004$  dan  $\beta = 0,80$

$$\rho = \beta \cdot r$$

$$= 0,80 \cdot 0,0002$$

$$= 0,0002$$

$$A_{g \text{ total}} = \rho \cdot A_{gr}$$

$$= 0,0002 \cdot 15 \cdot 10^7$$

$$= 2492,7 \text{ mm}^2$$

$$= 24,927 \text{ cm}^2$$

Dipakai: Tulangan utama 70 D 12-250  $\text{mm}^2 = 2714 \text{ mm}^2 > 2492,7 \text{ mm}^2$

## d. Begel pada Kolom

Tebal selimut beton ( $d_s$ ) = 100 mm

$$d = h - d_s$$

$$= 6500 - 100$$

$$= 6400 \text{ mm}$$

1. Gaya geser perlu kolom ( $V_{u,k}$ )

$$\begin{aligned} V_{u,k} &= \frac{Mu_2 - Mu_1}{\lambda k} \\ &= \frac{1129,64}{6,57} \\ &= 171,94 \text{ kN} \\ &= 171939,54 \text{ N} \end{aligned}$$

2. Gaya geser yang ditahan oleh beton ( $V_c$ )

$$\begin{aligned} V_c &= \left(1 + \frac{Nu_k}{14.A_g}\right) \frac{\sqrt{f_c'}}{6} \cdot b \cdot d \\ &= \left(1 + \frac{3161,10 \cdot 10^3}{14 \cdot 2500 \cdot 6500}\right) \frac{\sqrt{20}}{6} \cdot 2500 \cdot 6400 \\ &= 12091402,8 \text{ N} \end{aligned}$$

3. Gaya geser yang ditahan oleh beton ( $V_s$ ) dan  $V_{s,max}$ 

$$\begin{aligned} V_s &= \frac{V_u - \phi \cdot V_c}{\phi} \text{ dengan } \phi = 0,75 \\ &= \frac{171939,54 - 0,75 \cdot 12091402}{0,75} \text{ dengan } \phi = 0,75 \\ &= -11862150 \text{ N} \end{aligned}$$

$$\begin{aligned} V_{s,max} &= \frac{2}{3} \cdot \sqrt{f_c'} \cdot b \cdot d \\ &= \frac{2}{3} \cdot \sqrt{20} \cdot 2500 \cdot 6400 \\ &= 47702783,5 \text{ N} \text{ , syarat } V_s \leq V_{s,max} \dots \text{ OK} \end{aligned}$$

4. Luas begel perlu ( $A_{v,u}$ ) untuk setiap panjang kolom  $S = 1000 \text{ mm}$ , dengan memilih yang terbesar dari nilai  $A_v$  berikut:

$$\begin{aligned} A_v &= \frac{V_s \cdot S}{f_y \cdot d} \\ &= \frac{-11862150 \cdot 1000}{240 \cdot 6500} \\ &= -7722,75 \text{ mm}^2 \end{aligned}$$

$$\begin{aligned} A_v &= \frac{b \cdot S}{3 \cdot f_y} \\ &= \frac{2500 \cdot 1000}{3 \cdot 240} = 3472,2 \text{ mm}^2 \end{aligned}$$

$$\begin{aligned} A_v &= \frac{75 \sqrt{f_c'} \cdot b \cdot S}{1200 \cdot f_y} \\ &= \frac{75 \sqrt{20} \cdot 2500 \cdot 1000}{1200 \cdot 240} \\ &= 2911,55 \text{ mm}^2 \end{aligned}$$

Dipilih yang paling besar, jadi  $A_{v,u} = 3472,2 \text{ mm}^2$

Digunakan begel 2 kaki dengan  $d_p = 10 \text{ mm}$

## 5. Jarak antar begel

$$s = \frac{\frac{n}{4} \pi \cdot dp^2 \cdot S}{Av, u}$$

$$= \frac{\frac{2}{4} \pi \cdot 10^2 \cdot 1000}{3472,2}$$

$$= 45,24 \text{ mm}$$

Kontrol jarak:

$$s \leq 16D = 192 \text{ mm}$$

$$s \leq 48 \cdot dp = 480 \text{ mm}$$

$$s \leq d/2 = 3200 \text{ mm}$$

$$s \leq 600 \text{ mm}$$

Dipakai nilai terkecil dan dibulatkan ke bawah, yaitu  $s = 45 \text{ mm} \leq 45,24 \text{ mm}$

(Dibaca: "Begel 2 kaki berdiameter polos 10 mm dan berjarak 45 mm")

## 4.4.1.3.2. Pilar IV

Perencanaan tulangan pada pilar ini menggunakan tulangan praktis yang berfungsi untuk menghindari keretakan pilar akibat susut beton. Pilar ini hanya menahan beban sendiri dikarenakan beban rumah operasional pintu, jembatan pelayanan dan jembatan kendaraan sudah dibebankan seluruhnya pada pilar I dan pilar II. Perhitungan gaya dan momen pilar dapat dilihat pada Tabel 4.52.

Tabel 4.52. Gaya dan Momen Pilar III

Notasi	Nilai							Gaya		Lengan Momen	Momen			
	Lebar (m)	Tinggi (m)	Panjang (m)	Ratio	$\gamma$ (t/m <sup>3</sup> )			Pv (ton)	Ph (ton)	y (m)	My (ton.m)			
	[1]	[2]	[3]	[4]	[5]			[6]	[7]	[8]	[9]			
Wca	1,950	x	7,542	x	2,500	x	1,000	x	2,400	=	88,241	13,236	4,771	63,150
Total								$\Sigma V$	88,241		$\Sigma Mh$	63,150		
Sumber: Hasil Perhitungan							$\Sigma H$		13,236					
	Pu	=	1,200	x	$\Sigma V$			Mu	=	1,200	x	$\Sigma Mh$		
		=	1,200	x	88,241				=	1,200	x	63,150		
		=	105,89	ton					=	75,7799	ton			

Keterangan:

[ 1 ] = lebar tiap bagian (m)

[ 2 ] = tinggi tiap bagian (m)

[ 3 ] = panjang konstruksi

[ 4 ] = 1 digunakan untuk penampang persegi atau persegi panjang

= 0,5 digunakan untuk penampang segitiga

[ 5 ] = berat jenis beton bertulang = 2,4 (t/m<sup>3</sup>)= berat jenis air = 1,0 (t/m<sup>3</sup>)

- [ 6 ] = gaya vertikal (ton)  
 = [ 1 ] \* [ 2 ] \* [ 3 ] \* [ 4 ] \* [ 5 ] (untuk bangunan dan timbunan )  
 nilai (+) untuk arah gaya ke bawah  
 nilai (-) untuk arah gaya ke atas
- [ 7 ] = gaya horizontal (ton)  
 = [ 6 ] \* kh , dengan kh = 0,15 (untuk berat bangunan)  
 =  $\frac{7}{12} * [ 1 ] * [ 2 ] * [ 3 ] * [ 4 ] * [ 5 ] * kh$  (untuk tekanan air dinamis)  
 nilai (+) untuk arah gaya ke hilir  
 nilai (-) untuk arah gaya ke hulu
- [ 8 ] = lengan momen gaya berat konstruksi (m)  
 [ 9 ] = momen (ton.m)  
 = [ 7 ] \* [ 8 ]

Data Pilar IV :

- |                     |               |
|---------------------|---------------|
| 1. Lebar (h)        | = 1,95 m      |
| 2. Tebal (b)        | = 2,50 m      |
| 3. Tinggi           | = 7,54m       |
| 4. Mutu Bahan       |               |
| Beton (fc')         | = 20,00 Mpa   |
| Baja (fy)           | = 240,00 Mpa  |
| 5. Beban pada Pilar |               |
| a. Pu               | = 1058,90 kN  |
| b. Mu               | = 757,80 kN.m |
| c.                  |               |

a. Kontrol Kelangsingan

Pilar diasumsikan sebagai kolom tanpa pengaku, dibagian atas dan bawahnya jepit-jepit, maka  $k = 1,00$  (Tabel 2.7). Kelangsingan kolom dapat dihitung menggunakan persamaan (2-94) dan persamaan (2-95) sebagai berikut:

dimana:

$$\begin{aligned}
 A &= (\text{Lebar} \times \text{tebal}) \\
 &= (1,95 \times 2,50) \\
 &= 4,875 \text{ m}^2
 \end{aligned}$$



$$I = \frac{1}{12} \cdot b \cdot h^3 = \frac{1}{12} \cdot 2,5 \cdot (1,95)^3 = 1,545 \text{ m}^4$$

$$r = \sqrt{\frac{I}{A}}$$

$$= \sqrt{\frac{1,545}{4,875}} = 0,563 \text{ m}$$

$$k \frac{\lambda_{n,k}}{r} < 22$$

$$1,0 \frac{7,542}{0,563} < 22$$

$$13,40 < 22 \text{ (Termasuk Kolom Pendek)}$$

a. Luas Penampang Pilar

$$\begin{aligned} \text{Agr} &= \text{Lebar} \times \text{tebal} \\ &= (1,95 \times 2,50) \\ &= 4,875 \text{ m}^2 \\ &= 4,875 \cdot 10^6 \text{ mm}^2 \end{aligned}$$

b. Tulangan Kolom

Pada sumbu vertikal

$$\begin{aligned} \frac{P_u}{\phi \cdot \text{Agr} \cdot 0,85 \cdot f_c'} &= \frac{1058,90 \cdot 10^3}{0,65 \cdot 5,0 \cdot 10^6 \cdot 0,85 \cdot 20,00} \\ &= 0,020 < 0,10 \end{aligned}$$

ø ditingkatkan menjadi 0,80 maka:

$$\begin{aligned} \frac{P_u}{\phi \cdot \text{Agr} \cdot 0,85 \cdot f_c'} &= \frac{1058,90 \cdot 10^3}{0,80 \cdot 5,0 \cdot 10^6 \cdot 0,85 \cdot 20,00} \\ &= 0,016 < 0,10 \end{aligned}$$

$$\begin{aligned} e_t &= \frac{M_u}{P_u} \\ &= \frac{757,80}{1058,9} \\ &= 0,716 \text{ m} \end{aligned}$$

$$e_t/h = 757,80/1058,90 = 0,37$$

Pada sumbu horizontal

$$\begin{aligned} \frac{P_u}{\phi \cdot \text{Agr} \cdot 0,85 \cdot f_c'} \left( \frac{e_t}{h} \right) &= 0,016 \cdot 0,37 \\ &= 0,00586 \end{aligned}$$

Dengan  $d'/h = 100/1950 = 0,05$  diambil  $d'/h = 0,1$

Berdasarkan grafik pada Gambar 2.14, maka diperoleh  $r = 0,0008$  dan  $\beta = 0,80$

$$\begin{aligned} \rho &= \beta \cdot r \\ &= 0,80 \cdot 0,0008 = 0,0006 \end{aligned}$$

$$\begin{aligned}
 A_g \text{ total} &= \rho \cdot A_{gr} \\
 &= 0,0006 \cdot 4,8 \cdot 10^6 \\
 &= 3120,0 \text{ mm}^2 \\
 &= 31,20 \text{ cm}^2
 \end{aligned}$$

Dipakai: Tulangan utama 34 D 12-250 mm<sup>2</sup> = 3866 mm<sup>2</sup> > 3120 mm<sup>2</sup>

c. Begel pada Kolom

Tebal selimut beton (ds) = 100 mm

$$\begin{aligned}
 d &= h - ds \\
 &= 1950 - 100 \\
 &= 1850 \text{ mm}
 \end{aligned}$$

1. Gaya geser perlu kolom ( $V_{u,k}$ )

$$\begin{aligned}
 V_{u,k} &= \frac{M_{u2} - M_{u1}}{\lambda_k} \\
 &= \frac{757,80}{7,542} \\
 &= 100,48 \text{ kN} \\
 &= 100477,26 \text{ N}
 \end{aligned}$$

2. Gaya geser yang ditahan oleh beton ( $V_c$ )

$$\begin{aligned}
 V_c &= \left(1 + \frac{N_{u,k}}{14 \cdot A_g}\right) \frac{\sqrt{f_c'}}{6} \cdot b \cdot d \\
 &= \left(1 + \frac{1058,90 \cdot 10^3}{14 \cdot 2500 \cdot 1950}\right) \frac{\sqrt{20}}{6} \cdot 2500 \cdot 1850 \\
 &= 3500755,78 \text{ N}
 \end{aligned}$$

3. Gaya geser yang ditahan oleh beton ( $V_s$ ) dan  $V_{s,\text{maks}}$

$$\begin{aligned}
 V_s &= \frac{V_u - \phi \cdot V_c}{\phi} \text{ dengan } \phi = 0,75 \\
 &= \frac{100477,26 - 0,75 \cdot 3500755,78}{0,75} \\
 &= -3366786,1 \text{ N}
 \end{aligned}$$

$$\begin{aligned}
 V_{s,\text{maks}} &= \frac{2}{3} \cdot \sqrt{f_c'} \cdot b \cdot d \\
 &= \frac{2}{3} \cdot \sqrt{20} \cdot 2500 \cdot 1850 \\
 &= 13789085,9 \text{ N, syarat } V_s \leq V_{s,\text{maks}} \dots \text{ OK}
 \end{aligned}$$

4. Luas begel perlu ( $A_{v,u}$ ) untuk setiap panjang kolom  $S = 1000 \text{ mm}$ , dengan memilih yang terbesar dari nilai  $A_v$  berikut:

$$A_v = \frac{V_s \cdot S}{f_y \cdot d}$$

$$= \frac{-3366786,104 \cdot 1000}{240 \cdot 1850}$$

$$= -7582,85 \text{ mm}^2$$

$$A_v = \frac{b \cdot S}{3 \cdot f_y}$$

$$= \frac{2500 \cdot 1000}{3 \cdot 240} = 3472,2 \text{ mm}^2$$

$$A_v = \frac{75 \sqrt{f_c'} \cdot b \cdot S}{1200 \cdot f_y}$$

$$= \frac{75 \sqrt{20} \cdot 2500 \cdot 1000}{1200 \cdot 240}$$

$$= 2911,55 \text{ mm}^2$$

Dipilih yang paling besar, jadi  $A_{v,u} = 3472,2 \text{ mm}^2$

Digunakan begel 2 kaki dengan  $d_p = 10 \text{ mm}$

5. Jarak antar begel

$$s = \frac{\frac{n}{4} \cdot \pi \cdot d_p^2 \cdot S}{A_{v,u}}$$

$$= \frac{\frac{2}{4} \cdot \pi \cdot 10^2 \cdot 1000}{3472,2}$$

$$= 45,24 \text{ mm}$$

Kontrol jarak:

$$s \leq 16D = 192 \text{ mm}$$

$$s \leq 48 \cdot d_p = 480 \text{ mm}$$

$$s \leq d/2 = 925 \text{ mm}$$

$$s \leq 600 \text{ mm}$$

Dipakai nilai terkecil dan dibulatkan ke bawah, yaitu  $s = 45 \text{ mm} \leq 45,24 \text{ mm}$

(Dibaca: "Begel 2 kaki berdiameter polos 10 mm dan berjarak 45 mm")

#### 4.4.1.3.3. Pilar V

Perencanaan tulangan pada pilar ini menggunakan tulangan praktis yang berfungsi untuk menghindari keretakan pilar akibat susut beton. Pilar ini hanya menahan beban sendiri dikarenakan beban rumah operasional pintu, jembatan pelayanan dan jembatan kendaraan sudah dibebankan seluruhnya pada pilar I dan pilar II. Perhitungan gaya dan momen pilar dapat dilihat pada Tabel 4.53.

Tabel 4.53. Gaya dan Momen Pilar V

Notasi	Nilai							Gaya		Lengan Momen	Momen				
	Lebar (m)		Tinggi (m)		Panjang (m)		Ratio		$\gamma$ ( $t/m^3$ )		Pv (ton)	Ph (ton)	y (m)	My (ton.m)	
	[1]		[2]		[3]		[4]		[5]		[6]	[7]	[8]	[9]	
Wc5	0,680	x	11,570	x	2,500	x	1,000	x	2,400	=	148,301	22,245	6,785	150,933	
Wc6	3,020	x	11,570	x	2,500	x	0,500	x	2,400	=	329,315	49,397	4,857	239,906	
Wc7	1,250	x	11,570	x	1,250	x	0,500	x	2,400	x	$\pi$	68,153	10,223	6,785	69,363
Total											$\Sigma V$	545,769			
											$\Sigma H$	81,865		$\Sigma Mh$	460,202

Sumber: Hasil Perhitungan

Pu	=	1,200	x	$\Sigma V$		Mu	=	1,200	x	$\Sigma Mh$
	=	1,200	x	545,769			=	1,200	x	460,202
	=	654,922	ton				=	552,242	ton	

## Keterangan:

- [ 1 ] = lebar tiap bagian (m)  
 [ 2 ] = tinggi tiap bagian (m)  
 [ 3 ] = panjang konstruksi  
 [ 4 ] = 1 digunakan untuk penampang persegi atau persegi panjang  
 = 0,5 digunakan untuk penampang segitiga  
 [ 5 ] = berat jenis beton bertulang =  $2,4 (t/m^3)$   
 = berat jenis air =  $1,0 (t/m^3)$   
 [ 6 ] = gaya vertikal (ton)  
 = [ 1 ] \* [ 2 ] \* [ 3 ] \* [ 4 ] \* [ 5 ] (untuk bangunan dan timbunan )  
 nilai (+) untuk arah gaya ke bawah  
 nilai (-) untuk arah gaya ke atas  
 [ 7 ] = gaya horizontal (ton)  
 = [ 6 ] \* kh , dengan kh = 0,15 (untuk berat bangunan)  
 =  $7/12 * [ 1 ] * [ 2 ] * [ 3 ] * [ 4 ] * [ 5 ] * kh$  (untuk tekanan air dinamis)  
 nilai (+) untuk arah gaya ke hilir  
 nilai (-) untuk arah gaya ke hulu  
 [ 8 ] = lengan momen gaya berat konstruksi (m)  
 [ 9 ] = momen (ton.m)  
 = [ 7 ] \* [ 8 ]

## Data Pilar V :

1. Lebar (h) = 1,93 m
2. Tebal (b) = 2,50 m
3. Tinggi = 11,57 m
4. Mutu Bahan

$$\text{Beton } (f_c') = 20,00 \text{ Mpa}$$

$$\text{Baja } (f_y) = 240,00 \text{ Mpa}$$

#### 5. Beban pada Pilar

$$\text{a. } P_u = 6549,22 \text{ kN}$$

$$\text{b. } M_u = 5522,42 \text{ kN.m}$$

#### a. Kontrol Kelangsingan

Pilar diasumsikan sebagai kolom tanpa pengaku, dibagian atas dan bawahnya jepit-jepit, maka  $k = 1,00$  (Tabel 2.7). Kelangsingan kolom dapat dihitung menggunakan persamaan (2-94) dan persamaan (2-95) sebagai berikut:

dimana:

$$A = (\text{Lebar} \times \text{tebal})$$

$$= (1,93 \times 2,50)$$

$$= 4,825 \text{ m}^2$$

$$I = \frac{1}{12} \cdot b \cdot h^3 = \frac{1}{12} \cdot 2,5 \cdot (1,93)^3$$

$$= 1,498 \text{ m}^4$$

$$r = \sqrt{\frac{I}{A}}$$

$$= \sqrt{\frac{1,498}{4,825}} = 0,557 \text{ m}$$

$$k \frac{\lambda_{n,k}}{r} < 22$$

$$1,0 \frac{11,57}{0,557} < 22$$

$$20,77 < 22 \text{ (Termasuk Kolom Pendek)}$$

#### d. Luas Penampang Pilar

$$A_{gr} = (\text{Lebar} \times \text{tebal}) + (1/2 \cdot \pi \cdot r^2)$$

$$= (1,93 \times 2,50) + (1/2 \cdot \pi \cdot 1,25^2)$$

$$= 4,154 \text{ m}^2$$

$$= 4,15 \cdot 10^6 \text{ mm}^2$$

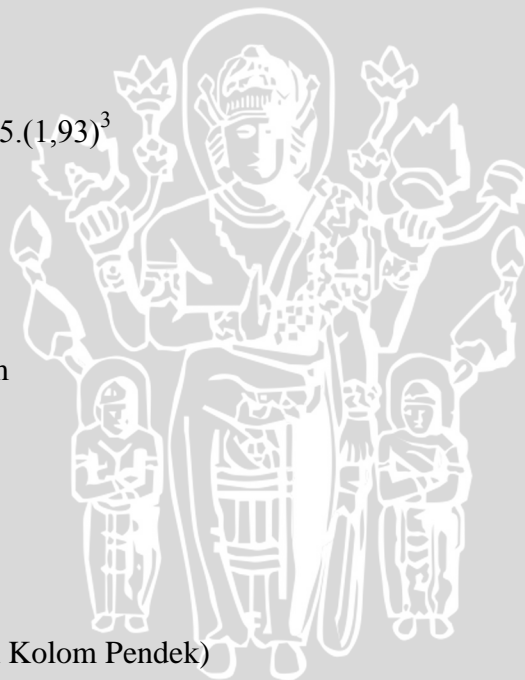

## e. Tulangan Kolom

Pada sumbu vertikal

$$\frac{P_u}{\phi \cdot \text{Agr} \cdot 0,85 \cdot f_c'} = \frac{6549,22 \cdot 10^3}{0,65 \cdot 4,1510^6 \cdot 0,85 \cdot 20,00}$$

$$= 0,143 < 0,10$$

$$e_t = \frac{M_u}{P_u}$$

$$= \frac{5522,42}{6549,22}$$

$$= 0,843 \text{ m}$$

$$e_t/h = 843,22/1930 = 0,44$$

Pada sumbu horizontal

$$\frac{P_u}{\phi \cdot \text{Agr} \cdot 0,85 \cdot f_c'} \left( \frac{e_t}{h} \right) = 0,143 \cdot 0,44$$

$$= 0,07173$$

Dengan  $d'/h = 100/1930 = 0,05$  diambil  $d'/h = 0,1$ Berdasarkan grafik pada Gambar 2.14, maka diperoleh  $r = 0,003$  dan  $\beta = 0,80$ 

$$\rho = \beta \cdot r$$

$$= 0,80 \cdot 0,0030$$

$$= 0,0024$$

$$\text{Ag total} = \rho \cdot \text{Agr}$$

$$= 0,0024 \cdot 4 \cdot 10^6$$

$$= 9970,5 \text{ mm}^2$$

$$= 99,705 \text{ cm}^2$$

Dipakai: Tulangan utama 95 D 12- 90  $\text{mm}^2 = 10704 \text{ mm}^2 > 9970,5 \text{ mm}^2$ 

## f. Begel pada Kolom

Tebal selimut beton ( $d_s$ ) = 100 mm

$$d = h - d_s$$

$$= 1930 - 100$$

$$= 1830 \text{ mm}$$

1. Gaya geser perlu kolom ( $V_{u,k}$ )

$$V_{u,k} = \frac{M_{u2} - M_{u1}}{\lambda_k}$$

$$= \frac{5522,42}{7,542}$$

$$= 732,22 \text{ kN} = 732222,24 \text{ N}$$

2. Gaya geser yang ditahan oleh beton ( $V_c$ )

$$\begin{aligned} V_c &= \left(1 + \frac{N_{u,k}}{14.A_g}\right) \frac{\sqrt{f_c'}}{6} . b . d \\ &= \left(1 + \frac{6549,22.10^3}{14.2500.1930}\right) \frac{\sqrt{20}}{6} . 2500.1830 \\ &= 3740616,194 \text{ N} \end{aligned}$$

3. Gaya geser yang ditahan oleh beton ( $V_s$ ) dan  $V_{s,max}$

$$\begin{aligned} V_s &= \frac{V_u - \phi . V_c}{\phi} \text{ dengan } \phi = 0,75 \\ &= \frac{732222,24 - 0,75.3740616,194}{0,75} \\ &= - 2764319,877 \text{ N} \end{aligned}$$

$$\begin{aligned} V_{s,max} &= \frac{2}{3} . \sqrt{f_c'} . b . d \\ &= \frac{2}{3} . \sqrt{20} . 2500.1830 \\ &= 13640014,66 \text{ N, syarat } V_s \leq V_{s,max} \dots \text{ OK} \end{aligned}$$

4. Luas begel perlu ( $A_{v,u}$ ) untuk setiap panjang kolom  $S = 1000 \text{ mm}$ , dengan memilih yang terbesar dari nilai  $A_v$  berikut:

$$\begin{aligned} A_v &= \frac{V_s . S}{f_y . d} \\ &= \frac{-2764319,877 . 1000}{240.1830} \\ &= - 6293,99 \text{ mm}^2 \end{aligned}$$

$$\begin{aligned} A_v &= \frac{b . S}{3 . f_y} \\ &= \frac{2500.1000}{3.240} = 3472,2 \text{ mm}^2 \end{aligned}$$

$$\begin{aligned} A_v &= \frac{75\sqrt{f_c'} . b . S}{1200 . f_y} \\ &= \frac{75\sqrt{20} . 2500.1000}{1200.240} \\ &= 2911,55 \text{ mm}^2 \end{aligned}$$

Dipilih yang paling besar, jadi  $A_{v,u} = 3472,2 \text{ mm}^2$

Digunakan begel 2 kaki dengan  $d_p = 10 \text{ mm}$

5. Jarak antar begel

$$\begin{aligned} s &= \frac{\frac{n}{4} \pi . d_p^2 . S}{A_{v,u}} \\ &= \frac{\frac{2}{4} \pi . 10^2 . 1000}{3472,2} \\ &= 45,24 \text{ mm} \end{aligned}$$

Kontrol jarak:

$$s \leq 16D = 192 \text{ mm}$$

$$s \leq 48.dp = 480 \text{ mm}$$

$$s \leq d/2 = 915 \text{ mm}$$

$$s \leq 600 \text{ mm}$$

Dipakai nilai terkecil dan dibulatkan ke bawah, yaitu  $s = 45 \text{ mm} \leq 45,24 \text{ mm}$

(Dibaca: “Begel 2 kaki berdiameter polos 10 mm dan berjarak 45 mm”)

Penulangan pada pilar I, II, III, IV dan V dapat dilihat pada Gambar 4.55.

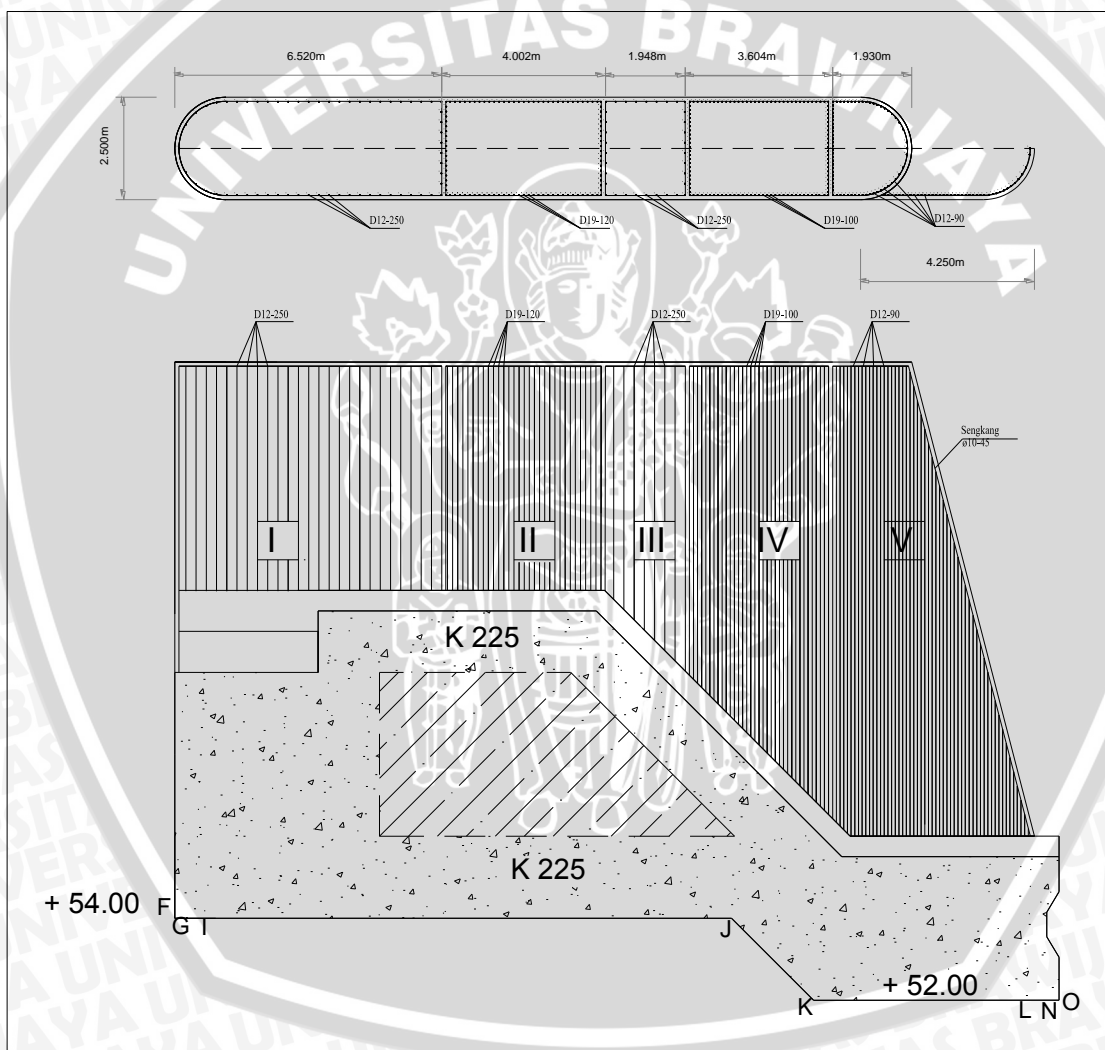

Gambar 4.55. Penulangan Pada Pilar I, II, III, IV dan V



#### 4.5.1.4. Pelimpah

Perencanaan pembetonan dan penulangan pada pelimpah ini menanggung beban air dan beban pintu yang diatas yaitu ditinjau seluas 1 m<sup>2</sup>. Berikut ini perhitungan dari pembetonan dan penulangan pelimpah:

##### 1. Data pelimpah:

- a. Elevasi muka air banjir = El. 66.07 m
- b. Elevasi puncak pelimpah = El. 62.00 m
- c. Beban pintu (per 1 meter) = 7,987 ton/m
- d. Tinggi muka air normal (H) = 4,07 m
- e. Lapisan beton
  - Tebal bruto (h) = 1000 mm
  - Tebal efektif (d) = 900 mm
- f. Lebar tinjauan (b) = 1000 mm
- g. Mutu beton (f<sub>c'</sub>) = 20,00 Mpa
- h. Mutu baja (f<sub>y</sub>) = 240,00 Mpa

##### 2. Beban pada Beton

###### a. Tekanan air per meter lebar

$$\begin{aligned}
 q &= H \cdot \gamma / m \\
 &= 4,07 \cdot 1,00 / m \\
 &= 4,07 \text{ ton/m}
 \end{aligned}$$

$$\begin{aligned}
 q \text{ total} &= q_{\text{air}} + q_{\text{pintu}} \\
 &= 4,07 + 7,987 \\
 &= 12,06 \text{ ton/m}^2
 \end{aligned}$$

###### b. Momen lentur

$$\begin{aligned}
 M &= \frac{1}{8} \cdot q \cdot l^2 \\
 &= \frac{1}{8} \cdot 12,06 \cdot 1,00^2 \\
 &= 1,5075 \text{ ton.m} \\
 &= 15,075 \text{ kNm}
 \end{aligned}$$

###### c. Momen ultimate

$$\begin{aligned}
 M_u &= 1,2 \cdot M \\
 &= 1,2 \cdot 15,075 \\
 &= 18,09 \text{ kNm}
 \end{aligned}$$

### 3. Perhitungan tulangan beton

$$K = \frac{M_u}{\phi \cdot b \cdot d^2}$$

$$= \frac{14,464 \cdot 10^6}{0,8 \cdot 1000 \cdot 900^2}$$

$$= 0,023 \text{ Mpa}$$

$$K_{\max} = \frac{382,5 \cdot \beta_1 \cdot f_c' \cdot (600 + f_y - 225 \cdot \beta_1)}{(600 + f_y)^2}$$

$$= \frac{382,5 \cdot 0,85 \cdot 20 \cdot (600 + 240 - 225 \cdot 0,85)}{(600 + 240)^2}$$

$$= 5,979 \text{ Mpa}$$

$$a = \left( 1 - \sqrt{1 - \frac{2K}{0,85 \cdot f_c'}} \right) d$$

$$= \left( 1 - \sqrt{1 - \frac{2 \cdot 0,023}{0,85 \cdot 20}} \right) 900$$

$$= 1,20 \text{ mm}$$

#### a. Tulangan utama (tarik)

$$A_s = \frac{0,85 \cdot f_c' \cdot a \cdot b}{f_y}$$

$$= \frac{0,85 \cdot 20 \cdot 1,20 \cdot 1000}{240}$$

$$= 84,83 \text{ mm}^2$$

$$\text{Dipakai tulangan} : \phi 10 - 450 \text{ mm} = 174,53 \text{ mm}^2 > 84,83 \text{ mm}^2$$

#### b. Tulangan pembagi (tarik)

$$A_{s,b} = 20\% \cdot A_{s,u}$$

$$= 20\% \cdot 84,83 \text{ mm}^2$$

$$= 16,97 \text{ mm}^2$$

$$\text{Dipakai tulangan} : \phi 6 - 450 \text{ mm} = 62,83 \text{ mm}^2 > 16,97 \text{ mm}^2$$

#### 4.5.1.5. Pelat Pondasi Bendung Gerak (*Barrage*)

Pelat pondasi pada bendung gerak ini berguna untuk menahan beban secara keseluruhan yang berada di atasnya. Baik itu berupa beban pilar, pintu maupun beban air. Momen yang ada dihitung dengan mengalikan eksentrisitas dengan beban vertikal yang terjadi. (lihat Tabel 4.5. Analisis Stabilitas Bendung Gerak pada Kondisi Normal (Gempa)). Berikut ini contoh perhitungannya:

Data:

Gaya vertikal rencana ultimit ( $P_u$ )	=	41773,17 kN
Eksentrisitas ( $e$ )	=	0,97
Momen rencana ultimit ( $M_u$ )	=	40494,73 kNm

Mutu beton, Kuat tekan beton ( $f_c'$ )	=	20,0	MPa
Mutu Baja, Tegangan leleh baja ( $f_y$ )	=	240	MPa
Tebal beton ( $h$ )	=	2000	mm
Selimit beton ( $p$ )	=	100	mm
Tebal efektif $d = h - p$	=	1900	mm
Lebar yang ditinjau ( $b$ )	=	15000	mm

Perhitungan:

$$K = \frac{M_u}{\phi \cdot b \cdot d^2}$$

$$= \frac{40494,73 \cdot 10^6}{0,8 \cdot 15000 \cdot 1900^2}$$

$$= 0,935 \text{ Mpa}$$

$$K_{\max} = \frac{382,5 \cdot \beta_1 \cdot f_c' \cdot (600 + f_y - 225 \cdot \beta_1)}{(600 + f_y)^2}$$

$$= \frac{382,5 \cdot 0,85 \cdot 20 \cdot (600 + 240 - 225 \cdot 0,85)}{(600 + 240)^2}$$

$$= 5,979 \text{ Mpa}$$

$$a = \left( 1 - \sqrt{1 - \frac{2K}{0,85 \cdot f_c'}} \right) d$$

$$= \left( 1 - \sqrt{1 - \frac{2 \cdot 0,935}{0,85 \cdot 20}} \right) 1900$$

$$= 107,52 \text{ mm}$$

a. Tulangan utama (tarik)

$$A_s = \frac{0,85 \cdot f_c' \cdot a \cdot b}{f_y}$$

$$= \frac{0,85 \cdot 20 \cdot 107,52 \cdot 15000}{240}$$

$$= 114237,53 \text{ mm}^2$$

$$\text{Dipakai tulangan : D25 - 50 mm} = 147262,16 \text{ mm}^2 > 114237,53 \text{ mm}^2$$

b. Tulangan pembagi (tarik)

$$A_{s,b} = 20\% \cdot A_{s,u}$$

$$= 20\% \cdot 114237,53 \text{ mm}^2$$

$$= 22847,51 \text{ mm}^2$$

$$\text{Dipakai tulangan : D16 - 125 mm} = 24127,43 \text{ mm}^2 > 22847,51 \text{ mm}^2$$



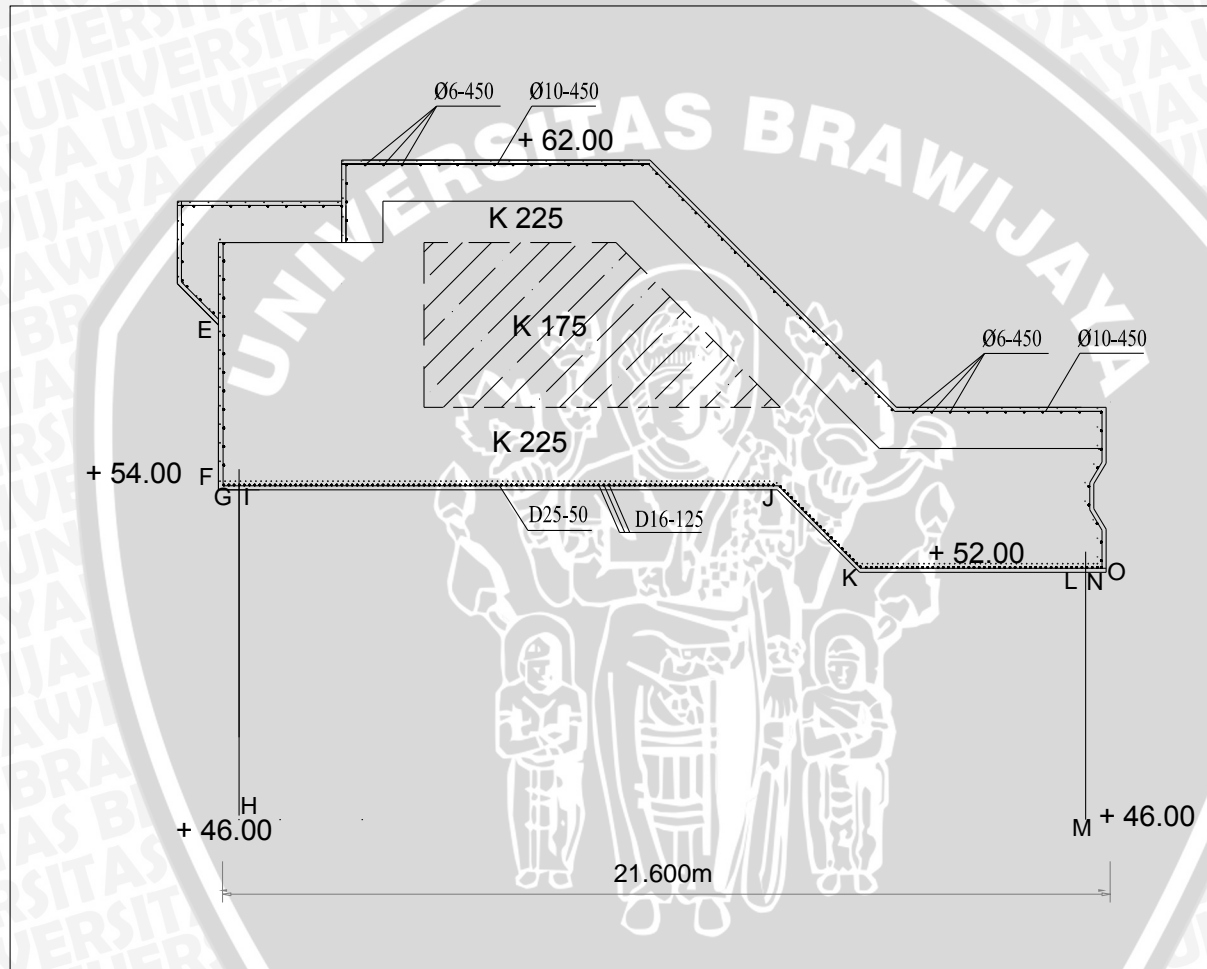

Gambar 4.56. Penulangan Pada Pelimpah dan Pelat Pondasi Bendung Gerak (Barrage)

#### 4.5.2. Pilar pada Bangunan Penguras (*Sluice Gate*)

Dalam analisis struktur pembeconan dan penulangan pilar pada bangunan penguras (*sluice gate*) perlu dilakukan anggapan atau asumsi. Adapun asumsi perhitungannya adalah sebagai berikut:

1. Pilar I (menanggung beban rumah operasi dan jembatan pelayanan) dan Pondasi Telapak Pilar I
2. Pilar II (menanggung beban jembatan kendaraan) dan Pondasi Telapak Pilar II
3. Pilar III, IV dan V (menanggung beban sendiri)
4. Pelimpah (menanggung beban air dan pintu)
5. Pelat Pondasi pada Bangunan Penguras (*Sluice Gate*)

##### 4.5.2.1. Pilar I dan Telapak Pondasi Pilar I

Perencanaan penulangan pada tubuh pilar berdasarkan luas penampang tubuh pilar serta momen lentur dan gaya tekan sentris akibat berat struktur di atasnya. Gaya dan momen lentur yang bekerja pada pilar dapat dilihat pada Tabel. 4.54 sedangkan gambar pilar dan diagram gaya yang bekerja pada pilar dapat dilihat pada Gambar 4.57 dan Gambar 4.58.

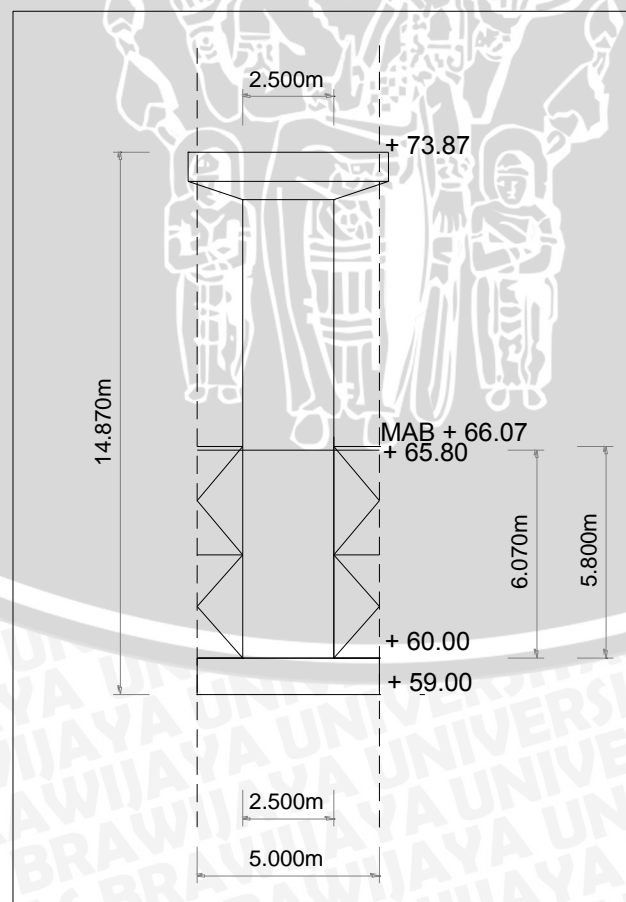

Gambar 4.57. Pilar I Kondisi Muka Air Banjir Gempa (Tampak Depan)

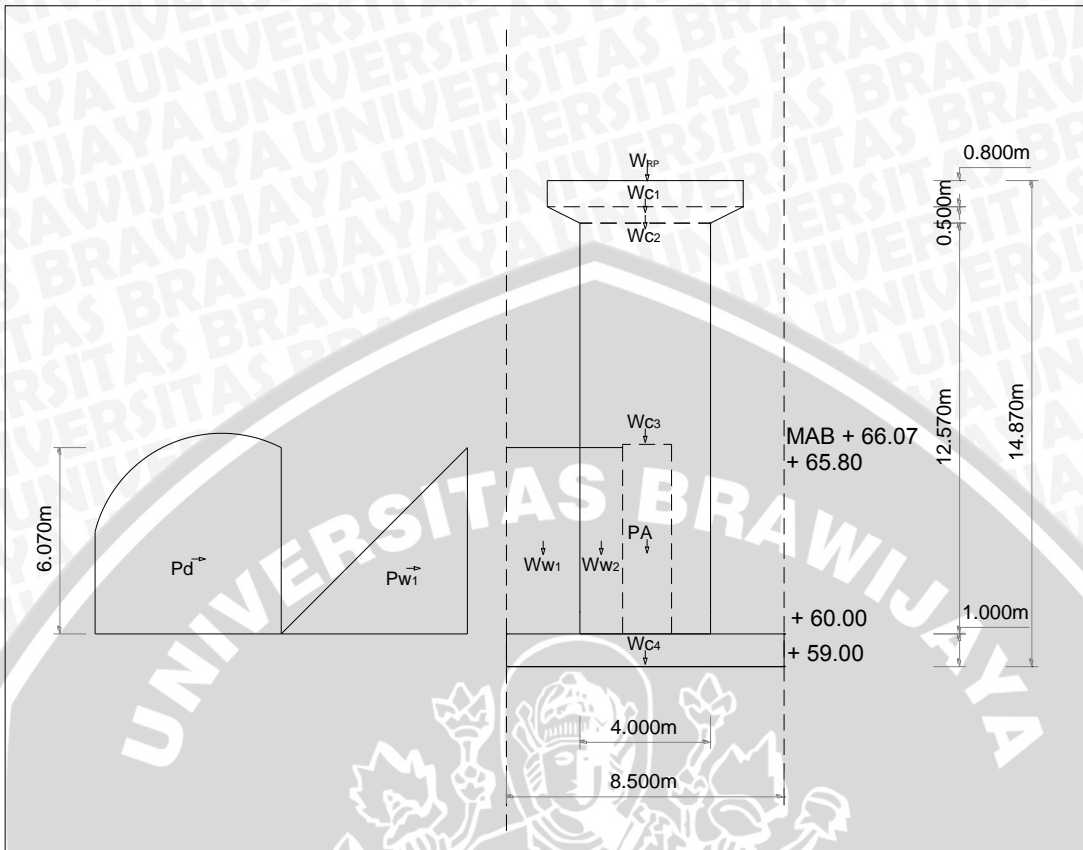

**Gambar 4.58. Diagram Gaya Pada Pilar I Kondisi Muka Air Banjir Gempa (Tampak Samping)**

**Tabel 4.54. Gaya dan Momen Pilar pada Rumah Operasi Pintu Akibat Gempa**

Notasi	Nilai							Gaya		Lengan Momen	Momen
	Lebar (m)	Tinggi (m)	Panjang (m)	Ratio	$\gamma$ (t/m <sup>3</sup> )		Pv (ton)	Ph (ton)	y (m)	My (ton.m)	
	[1]	[2]	[3]	[4]	[5]		[6]	[7]	[8]	[9]	
WRP							= 29,875	4,481	16,870	75,599	
WC1	4,000	x 0,800	x 2,500	x 1,000	x 2,400	=	19,200	2,880	14,470	41,674	
WC2	4,000	x 0,500	x 2,500	x 1,000	x 2,400	=	12,000	1,800	13,820	24,876	
WC3	4,000	x 12,570	x 2,500	x 1,000	x 2,400	=	301,680	45,252	7,285	329,661	
Pw1	6,070	x 6,070	x 5,000	x 0,500	x 1,000	=		92,112	2,023	186,374	
Pd	6,070	x 6,070	x 5,000	x 7/12	x 1,000	=		16,120	2,023	32,615	
Total						$\Sigma V$	362,755		$\Sigma Mh$	690,798	
						$\Sigma H$		162,645			

Sumber: Hasil Perhitungan

$Pu = 1,200 \times \Sigma V$ $= 1,200 \times 362,755$ $= 435,306 \text{ ton}$	$Mu = 1,200 \times \Sigma Mh$ $= 1,200 \times 690,798$ $= 828,958 \text{ ton}$
---	--

Keterangan:

[ 1 ] = lebar tiap bagian (m)

[ 2 ] = tinggi tiap bagian (m)

[ 3 ] = panjang konstruksi

- [ 4 ] = 1 digunakan untuk penampang persegi atau persegi panjang  
 = 0,5 digunakan untuk penampang segitiga
- [ 5 ] = berat jenis beton bertulang = 2,4 (t/m<sup>3</sup>)  
 = berat jenis air = 1,0 (t/m<sup>3</sup>)
- [ 6 ] = gaya vertikal (ton)  
 = [ 1 ] \* [ 2 ] \* [ 3 ] \* [ 4 ] \* [ 5 ] (untuk bangunan dan timbunan )  
 nilai (+) untuk arah gaya ke bawah  
 nilai (-) untuk arah gaya ke atas
- [ 7 ] = gaya horizontal (ton)  
 = [ 6 ] \* kh , dengan kh = 0,15 (untuk berat bangunan)  
 = 7/12 \* [ 1 ] \* [ 2 ] \* [ 3 ] \* [ 4 ] \* [ 5 ] \* kh (untuk tekanan air dinamis)  
 nilai (+) untuk arah gaya ke hilir  
 nilai (-) untuk arah gaya ke hulu
- [ 8 ] = lengan momen gaya berat konstruksi (m)
- [ 9 ] = momen (ton.m)  
 = [ 7 ] \* [ 8 ]

#### Data Pilar I :

- |                     |                |
|---------------------|----------------|
| 1. Lebar (h)        | = 4,00 m       |
| 2. Tebal (b)        | = 2,50 m       |
| 3. Tinggi           | = 13,87 m      |
| 4. Mutu Bahan       |                |
| Beton (fc')         | = 20,00 Mpa    |
| Baja (fy)           | = 240,00 Mpa   |
| 5. Beban pada Pilar |                |
| a. Pu               | = 4353,06 kN   |
| b. Mu               | = 8289,58 kN.m |

#### a. Kontrol Kelangsingan

Pilar diasumsikan sebagai kolom tanpa pengaku, dibagian atas dan bawahnya jepit-jepit, maka  $k = 1,00$  (Tabel 2.7). Kelangsingan kolom dapat dihitung menggunakan persamaan (2-94) dan persamaan (2-95) sebagai berikut:

dimana:

$$A = b \cdot h \\ = 2,5 \times 4,0 = 10,00 \text{ m}^2$$

$$I = \frac{1}{12} \cdot b \cdot h^3 \\ = \frac{1}{12} \cdot 2,5 \cdot (4,0)^3 \\ = 13,333 \text{ m}^4$$

$$r = \sqrt{\frac{I}{A}} \\ = \sqrt{\frac{13,33}{10,00}} = 1,155 \text{ m}$$

$$k \frac{\lambda_{n,k}}{r} < 22$$

$$1,0 \frac{13,87}{1,155} < 22$$

$$12,02 < 22 \text{ (Termasuk Kolom Pendek)}$$

b. Luas Penampang Pilar

$$\text{Agr} = \text{Lebar} \times \text{Tebal} \\ = 4,00 \times 2,50 \\ = 10,00 \text{ m}^2 \\ = 10^7 \text{ mm}^2$$

c. Tulangan Kolom

Pada sumbu vertikal

$$\frac{P_u}{\phi \cdot \text{Agr} \cdot 0,85 \cdot f_c'} = \frac{4353,06 \cdot 10^3}{0,65 \cdot 10^7 \cdot 0,85 \cdot 20,00} \\ = 0,039 < 0,10$$

Ø ditingkatkan menjadi 0,80 maka:

$$\frac{P_u}{\phi \cdot \text{Agr} \cdot 0,85 \cdot f_c'} = \frac{4353,06 \cdot 10^3}{0,80 \cdot 10^7 \cdot 0,85 \cdot 20,00} \\ = 0,032 < 0,10$$

$$e_t = \frac{M_u}{P_u} \\ = \frac{8289,58}{4353,6} \\ = 1,904 \text{ m}$$

$$e_t/h = 1904,31/4000 = 0,48$$

Pada sumbu horizontal

$$\frac{P_u}{\phi \cdot \text{Agr} \cdot 0,85 \cdot f_c'} \left( \frac{e_t}{h} \right) = 0,032 \cdot 0,48 = 0,015$$

Dengan  $d'/h = 1000/4000 = 0,03$  diambil  $d'/h = 0,10$

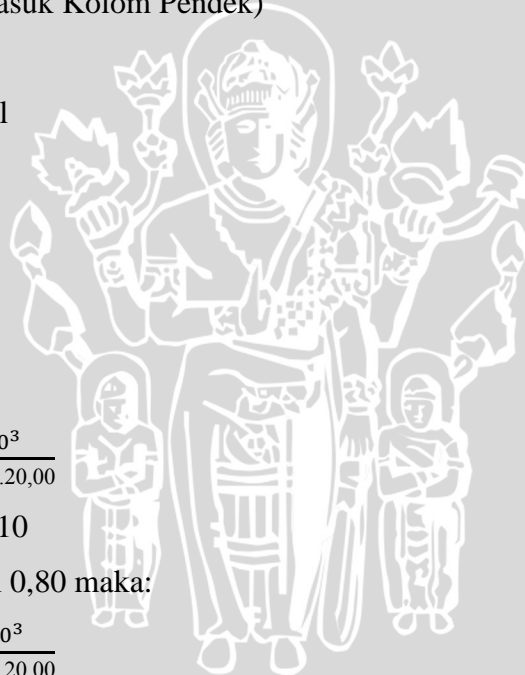



Berdasarkan grafik pada Gambar 2.14, maka diperoleh  $r = 0,0045$  dan  $\beta = 0,80$

$$\begin{aligned}\rho &= \beta \cdot r \\ &= 0,80 \cdot 0,0045 \\ &= 0,0036\end{aligned}$$

$$\begin{aligned}A_g \text{ total} &= \rho \cdot A_g r \\ &= 0,0036 \cdot 10^7 \\ &= 36000 \text{ mm}^2 \\ &= 360240 \text{ cm}^2\end{aligned}$$

Dipakai: Tulangan utama 128 D 19-100  $\text{mm}^2 = 36291,67 \text{ mm}^2 > 36000 \text{ mm}^2$

d. Begel pada Kolom

Tebal selimut beton ( $d_s$ ) = 100 mm

$$\begin{aligned}d &= h - d_s \\ &= 4000 - 100 \\ &= 3900 \text{ mm}\end{aligned}$$

1. Gaya geser perlu kolom ( $V_{u,k}$ )

$$\begin{aligned}V_{u,k} &= \frac{M_{u2} - M_{u1}}{\lambda_k} \\ &= \frac{8289,58}{13,87} \\ &= 597,66 \text{ kN} \\ &= 597662,56 \text{ N}\end{aligned}$$

2. Gaya geser yang ditahan oleh beton ( $V_c$ )

$$\begin{aligned}V_c &= \left(1 + \frac{N_{u,k}}{14 \cdot A_g}\right) \frac{\sqrt{f_c'}}{6} \cdot b \cdot d \\ &= \left(1 + \frac{4353,06 \cdot 10^3}{14 \cdot 2500 \cdot 4000}\right) \frac{\sqrt{20}}{6} \cdot 2500 \cdot 3900 \\ &= 7493182,704 \text{ N}\end{aligned}$$

3. Gaya geser yang ditahan oleh beton ( $V_s$ ) dan  $V_{s,\text{maks}}$

$$\begin{aligned}V_s &= \frac{V_u - \phi \cdot V_c}{\phi} \text{ dengan } \phi = 0,75 \\ &= \frac{597662,56 - 0,75 \cdot 7493182,704}{0,75} \text{ dengan } \phi = 0,75 \\ &= -6696299,294 \text{ N}\end{aligned}$$

$$\begin{aligned}V_{s,\text{maks}} &= \frac{2}{3} \cdot \sqrt{f_c'} \cdot b \cdot d \\ &= \frac{2}{3} \cdot \sqrt{20} \cdot 2500 \cdot 3900 = 29068883,71 \text{ N}, \text{ syarat } V_s \leq V_{s,\text{maks}} \dots \text{ OK}\end{aligned}$$

4. Luas begel perlu ( $A_{v,u}$ ) untuk setiap panjang kolom  $S = 1000$  mm, dengan memilih yang terbesar dari nilai  $A_v$  berikut:

$$\begin{aligned} A_v &= \frac{V_s \cdot S}{f_y \cdot d} \\ &= \frac{-6696299,29 \cdot 1000}{240 \cdot 3900} \\ &= -7154,17 \text{ mm}^2 \end{aligned}$$

$$\begin{aligned} A_v &= \frac{b \cdot S}{3 \cdot f_y} \\ &= \frac{2500 \cdot 1000}{3 \cdot 240} \\ &= 3472,2 \text{ mm}^2 \end{aligned}$$

$$\begin{aligned} A_v &= \frac{75 \sqrt{f_c'} \cdot b \cdot S}{1200 \cdot f_y} \\ &= \frac{75 \sqrt{20} \cdot 2500 \cdot 1000}{1200 \cdot 240} \\ &= 2911,55 \text{ mm}^2 \end{aligned}$$

Dipilih yang paling besar, jadi  $A_{v,u} = 3472,2 \text{ mm}^2$

Digunakan begel 2 kaki dengan  $d_p = 10$  mm

5. Jarak antar begel

$$\begin{aligned} s &= \frac{\frac{n}{4} \cdot \pi \cdot d_p^2 \cdot S}{A_{v,u}} \\ &= \frac{\frac{2}{4} \cdot \pi \cdot 10^2 \cdot 1000}{3472,2} \\ &= 45,24 \text{ mm} \end{aligned}$$

Kontrol jarak:

$$s \leq 16D = 304 \text{ mm}$$

$$s \leq 48 \cdot d_p = 480 \text{ mm}$$

$$s \leq d/2 = 1950 \text{ mm}$$

$$s \leq 600 \text{ mm}$$

Dipakai nilai terkecil dan dibulatkan ke bawah, yaitu  $s = 45 \text{ mm} \leq 45,24$

(Dibaca: "Begel 2 kaki berdiameter polos 10 mm dan berjarak 45 mm")

## e. Telapak Pondasi

Gaya dan momen yang bekerja pada pondasi telapak dapat dilihat pada Tabel. 4.55.

**Tabel 4.55. Gaya dan Momen Pondasi Telapak Akibat Gempa**

Notasi	Nilai							Gaya		Lengan Momen	Momen		
	Lebar (m)		Tinggi (m)		Panjang (m)		Ratio		$\gamma$ ( $t/m^3$ )	Pv (ton)	Ph (ton)	y (m)	My (ton.m)
	[1]		[2]		[3]		[4]		[5]	[6]	[7]	[8]	[9]
RP										= 29,875	4,481	16,870	75,599
PA										30,478	4,572	3,900	17,829
Wc1	4,000	x	0,800	x	2,500	x	1,000	x	2,400	= 19,200	2,880	14,470	41,674
Wc2	4,000	x	0,500	x	2,500	x	1,000	x	2,400	= 12,000	1,800	13,820	24,876
Wc3	4,000	x	12,570	x	2,500	x	1,000	x	2,400	= 301,680	45,252	7,285	329,661
Wc4	8,500	x	1,000	x	5,000	x	1,000	x	2,400	= 102,000	15,300	0,500	7,650
Ww1	2,250	x	6,070	x	5,000	x	1,000	x	1,000	= 68,288			
Ww2	1,300	x	6,070	x	2,500	x	1,000	x	1,000	= 19,728			
Pw1	6,070	x	6,070	x	5,000	x	0,500	x	1,000	=	92,112	2,023	186,374
Pd	6,070	x	6,070	x	5,000	x	7/12	x	1,000	=	16,120	2,023	32,615
Total									$\Sigma V$	495,233		$\Sigma Mh$	716,278
									$\Sigma H$		182,517		

Sumber: Hasil Perhitungan

Pu	=	1,200	x	$\Sigma V$	Mu	=	1,200	x	$\Sigma Mh$
	=	1,200	x	495,233		=	1,200	x	716,278
	=	594,279	ton			=	859,533	ton	

## Keterangan:

- [ 1 ] = lebar tiap bagian (m)
- [ 2 ] = tinggi tiap bagian (m)
- [ 3 ] = panjang konstruksi
- [ 4 ] = 1 digunakan untuk penampang persegi atau persegi panjang  
= 0,5 digunakan untuk penampang segitiga
- [ 5 ] = berat jenis beton bertulang =  $2,4 (t/m^3)$   
= berat jenis air =  $1,0 (t/m^3)$
- [ 6 ] = gaya vertikal (ton)  
= [ 1 ] \* [ 2 ] \* [ 3 ] \* [ 4 ] \* [ 5 ] (untuk bangunan dan timbunan )  
nilai (+) untuk arah gaya ke bawah  
nilai (-) untuk arah gaya ke atas
- [ 7 ] = gaya horizontal (ton)  
= [ 6 ] \* kh , dengan kh = 0,15 (untuk berat bangunan)  
=  $7/12 * [ 1 ] * [ 2 ] * [ 3 ] * [ 4 ] * [ 5 ] * kh$  (untuk tekanan air dinamis)  
nilai (+) untuk arah gaya ke hilir  
nilai (-) untuk arah gaya ke hulu
- [ 8 ] = lengan momen gaya berat konstruksi (m)
- [ 9 ] = momen (ton.m)  
= [ 7 ] \* [ 8 ]

Data pondasi telapak:

1. Lebar (B) = 5,00 m
2. Panjang (L) = 8,50 m
3. Tebal (h) = 1,00 m
4. Panjang Kolom (hk) = 4,00 m
5. Lebar Kolom (bk) = 2,50 m
6. Tebal Selimut (ds) = 0,10 m
7. Mutu Bahan
  - Beton (fc') = 20,00 Mpa
  - Baja (fy) = 240 Mpa
8. Beban pada Pondasi Telapak
  - Pu = 5942,79 kN
  - Mu = 8595,33 kNm

Langkah perhitungan pondasi telapak adalah sebagai berikut:

1. Menghitung tegangan

$$\sigma_{\max,\min} = \frac{P_{u,k}}{B.L} \pm \frac{M_{u,x}}{\frac{1}{6}.B.L^2}$$

$$= \frac{5942,79}{5,00.8,50} \pm \frac{8595,33}{\frac{1}{6}.5,0.8,5^2}$$

$$\sigma_{\max} = 139,83 + 142,76$$

$$= 282,59 \text{ kN/m}^2$$

$$\sigma_{\min} = 139,83 - 142,76$$

$$= -2,93 \text{ kN/m}^2$$

2. Kontrol Tegangan Geser 1 Arah

$$d_s = 100 \text{ mm}$$

$$d = h - d_s$$

$$= 1000 - 100$$

$$= 900 \text{ mm}$$

$$a = \frac{L}{2} - \frac{h_k}{2} - d$$

$$= \frac{8500}{2} - \frac{4000}{2} - 900$$

$$= 1350 \text{ mm} = 1,35 \text{ m}$$

$$\begin{aligned}\sigma_a &= \sigma_{\min} + \frac{(L-a) \cdot (\sigma_{\max} - \sigma_{\min})}{L} \\ &= -2,93 + \frac{(8500-1350) \cdot (282,59 - (-2,93))}{8500} \\ &= 237,24 \text{ kN/mm}^2\end{aligned}$$

Gaya tekan ke atas ( $V_u$ )

$$\begin{aligned}V_u &= a \cdot B \left( \frac{\sigma_{\max} + \sigma_a}{2} \right) \\ &= 1,35 \cdot 5,0 \left( \frac{282,59 + 237,24}{2} \right) \\ &= 1754,44 \text{ kN}\end{aligned}$$

Gaya geser yang dapat ditahan oleh beton ( $\phi V_c$ ) dengan  $\phi = 0,75$

$$\begin{aligned}V_c &= \frac{\sqrt{f_c'}}{6} B d \cdot \phi \\ &= \frac{\sqrt{20}}{6} 5000 \cdot 900 \cdot 0,75 \\ &= 2515,58 \text{ kN}\end{aligned}$$

Kontrol  $V_u = 1754,44 \text{ kN} \leq \phi \cdot V_c = 2515,58 \text{ kN} \dots \text{OK}$

### 3. Kontrol Tegangan Geser 2 Arah (Geser Pons)

$$(b + d) = (2500 + 900) = 3400 \text{ mm} = 3,40 \text{ m}$$

$$(h + d) = (4000 + 900) = 4900 \text{ mm} = 4,90 \text{ m}$$

a. Gaya Tekan ke atas (Geser Pons)

$$\begin{aligned}V_u &= \{B \cdot L - (b+d)(h+d)\} \left( \frac{\sigma_{\max} + \sigma_{\min}}{L} \right) \\ &= \{8500 \cdot 5000 - 3400 \cdot 4900\} \left( \frac{282,59 + (-2,93)}{8500} \right) \\ &= 3613,22 \text{ kN}\end{aligned}$$

$$s = \frac{hk}{bk} = \frac{4,00}{2,50} = 1,6$$

$$\begin{aligned}b_o &= 2\{(bk+d) + (hk+d)\} \\ &= 2\{(2500+900) + (4000+900)\} \\ &= 16600 \text{ mm}\end{aligned}$$

b. Gaya geser yang ditahan beton ( $\phi V_c$ )

$$\begin{aligned}V_c &= \left( 1 + \frac{2}{\beta_c} \right) \frac{\sqrt{f_c'} b_o d}{6} \\ &= \left( 1 + \frac{2}{1,6} \right) \frac{\sqrt{20} \cdot 16600 \cdot 900}{6} \\ &= 25055141,69 \text{ N} \\ &= 25055,14 \text{ kN}\end{aligned}$$

$$\begin{aligned}
 V_c &= \left(2 + \frac{\alpha_s \cdot d}{b_o}\right) \frac{\sqrt{f_c'} \cdot b_o \cdot d}{12} \\
 &= \left(2 + \frac{30 \cdot 900}{16600}\right) \frac{\sqrt{20} \cdot 16600 \cdot 900}{12} \\
 &= 20191693,84 \text{ N} \\
 &= 20191,69 \text{ kN}
 \end{aligned}$$

$$\begin{aligned}
 V_c &= \left(\frac{1}{3}\right) \sqrt{f_c'} \cdot b_o \cdot d \\
 &= \left(\frac{1}{3}\right) \sqrt{20} \cdot 16600 \cdot 900 \\
 &= 22271237,1 \text{ N} \\
 &= 22271,24 \text{ kN}
 \end{aligned}$$

Dipilih gaya geser yang terkecil yaitu  $V_c = 20191,69 \text{ kN}$

Kontrol:  $V_u = 3613,22 \text{ kN} \leq \phi V_c = 0,75 \cdot 20191,69 \text{ kN}$

$V_u = 3613,22 \text{ kN} \leq \phi V_c = 15144 \text{ kN} \dots \text{OK}$

#### 4. Tulangan Pondasi

##### a. Tulangan arah x-x

$$\begin{aligned}
 x &= \frac{L}{2} - \frac{hk}{2} \\
 &= \frac{8,50}{2} - \frac{4,00}{2} \\
 &= 2,25 \text{ m}
 \end{aligned}$$

Menghitung  $\sigma_x$  = tegangan tanah pada jarak x

$$\begin{aligned}
 \sigma_x &= \sigma_{\min} + \frac{L-x}{L} (\sigma_{\max} - \sigma_{\min}) \\
 &= -2,93 + \frac{8,50-2,25}{8,50} (282,59 - (-2,93)) \\
 &= 207,01 \text{ kN/m}^2
 \end{aligned}$$

Momen yang terjadi ( $M_u$ )

$$\begin{aligned}
 M_u &= \frac{1}{2} \cdot \sigma_x \cdot x^2 + \frac{1}{3} (\sigma_{\max} - \sigma_x) x^2 \\
 &= \frac{1}{2} \cdot 207,01 \cdot 2,25^2 + \frac{1}{3} (282,59 - 207,01) 2,25^2 \\
 &= 651,54 \text{ kNm}
 \end{aligned}$$

Faktor momen pikul ( $K$ ) dan ( $K_{\max}$ )

$$\begin{aligned}
 K &= M_u / (\phi \cdot b \cdot d^2) \\
 &= 651,54 \cdot 10^6 / (0,80 \cdot 1000 \cdot 900^2) \\
 &= 1,005 \text{ Mpa}
 \end{aligned}$$

$$\begin{aligned}
 K_{\max} &= \frac{382,5 \cdot \beta_1 \cdot f_c' \cdot (600 + f_y - 225 \cdot \beta_1)}{(600 + f_y)^2} \\
 &= \frac{382,5 \cdot 0,85 \cdot 20 \cdot (600 + 240 - 225 \cdot 240)}{(600 + 240)^2} \\
 &= 5,979 \text{ Mpa}
 \end{aligned}$$

Tinggi blok tegangan beton tekan persegi ekuivalen (a)

$$\begin{aligned}
 a &= \left(1 - \sqrt{1 - \frac{2K}{0,85 \cdot f_c'}}\right) d \\
 &= \left(1 - \sqrt{1 - \frac{2 \cdot 1,005}{0,85 \cdot 20}}\right) 900 \\
 &= 54,90 \text{ mm}
 \end{aligned}$$

Luas tulangan diperlukan ( $A_{s,u}$ )

$$\begin{aligned}
 A_{s,u} &= \frac{0,85 \cdot f_c' \cdot a \cdot b}{f_y} \\
 &= \frac{0,85 \cdot 20 \cdot 54,90 \cdot 1000}{240} \\
 &= 3889,096 \text{ mm}^2
 \end{aligned}$$

Tulangan yang digunakan

D19 – 50

$$A_s = 5670,57 \text{ mm}^2 > A_{s,u} = 3889,096 \text{ mm}^2$$

b. Tulangan arah y-y

$$\begin{aligned}
 x &= \frac{B}{2} - \frac{b_k}{2} \\
 &= \frac{5,00}{2} - \frac{2,50}{2} \\
 &= 1,25 \text{ m}
 \end{aligned}$$

Momen yang terjadi ( $M_u$ )

$$\begin{aligned}
 M_u &= \frac{1}{2} \cdot \sigma_{\max} \cdot x^2 \\
 &= \frac{1}{2} \cdot 282,59 \cdot 1,25^2 \\
 &= 220,77 \text{ kNm}
 \end{aligned}$$

Faktor momen pikul (K) dan ( $K_{\max}$ )

$$\begin{aligned}
 K &= M_u / (\phi \cdot b \cdot d^2) \\
 &= 220,77 \cdot 10^6 / (0,80 \cdot 1000 \cdot 900^2) \\
 &= 0,341 \text{ Mpa}
 \end{aligned}$$

$$\begin{aligned}
 K_{\max} &= \frac{382,5 \cdot \beta_1 \cdot f_c' \cdot (600 + f_y - 225 \cdot \beta_1)}{(600 + f_y)^2} \\
 &= \frac{382,5 \cdot 0,85 \cdot 20 \cdot (600 + 240 - 225 \cdot 240)}{(600 + 240)^2} = 5,979 \text{ Mpa}
 \end{aligned}$$

Tinggi blok tegangan beton tekan persegi ekuivalen (a)

$$\begin{aligned} a &= \left(1 - \sqrt{1 - \frac{2K}{0,85 \cdot f_c'}}\right) d \\ &= \left(1 - \sqrt{1 - \frac{2,0,341}{0,85 \cdot 20}}\right) 900 \\ &= 18,22 \text{ mm} \end{aligned}$$

Luas tulangan diperlukan ( $A_{s,u}$ )

$$\begin{aligned} A_{s,u} &= \frac{0,85 \cdot f_c' \cdot a \cdot b}{f_y} \\ &= \frac{0,85 \cdot 20 \cdot 18,22 \cdot 1000}{240} \\ &= 1290,69 \text{ mm}^2 \end{aligned}$$

Untuk jalur pusat selebar B = 5,00 m

$$\begin{aligned} A_{s,pusat} &= (2 \cdot B \cdot A_{s,u}) / (L + B) \\ &= (2 \cdot 5,00 \cdot 1290,69) / (8,50 + 5,00) \\ &= 956,07 \text{ mm}^2 \end{aligned}$$

Tulangan yang digunakan

D19 – 250

$$A_s = 1134,11 \text{ mm}^2 > A_{s,u} = 956,07 \text{ mm}^2$$

Untuk jalur tepi (diluar jalur pusat)

$$\begin{aligned} A_{s,tepi} &= A_{s,u} - A_{s,pusat} \\ &= 1290,69 - 956,07 \\ &= 156,58 \text{ mm}^2 \end{aligned}$$

Tulangan yang digunakan

D19 – 450

$$A_s = 630,06 \text{ mm}^2 > A_{s,u} = 156,58 \text{ mm}^2$$

Detail Gambar Penulangan Pilar I dapat dilihat pada Gambar 4.59 sampai 4.61.





**Gambar 4.59. Tulangan Pilar I (Tampak Atas)**

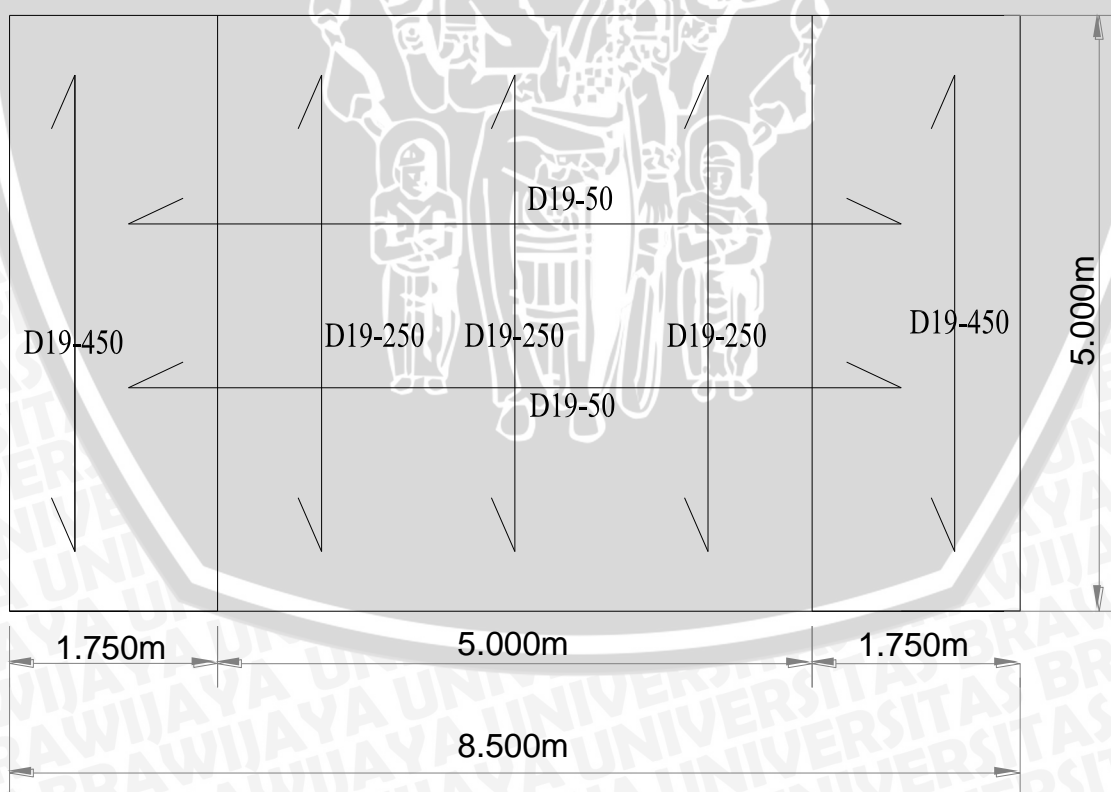

**Gambar 4.60. Pondasi Telapak Pilar I**

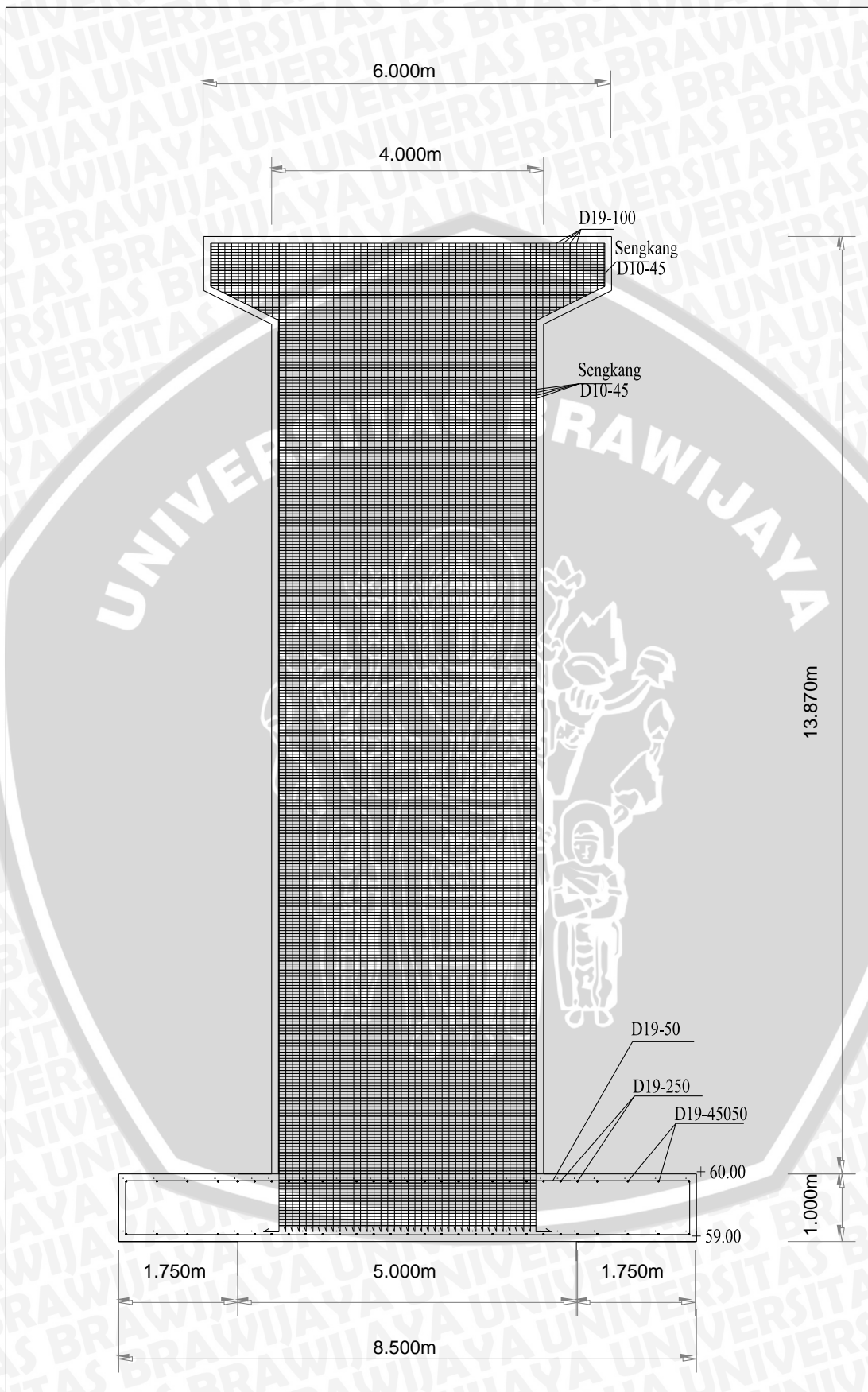

Gambar 4.61. Tulangan Pilar I

#### 4.5.2.2. Pilar II dan Pondasi Telapak

Perencanaan penulangan pada tubuh pilar berdasarkan luas penampang tubuh pilar serta momen lentur dan gaya tekan sentris akibat berat struktur di atasnya. Gaya dan momen lentur yang bekerja pada pilar dapat dilihat pada Tabel. 4.56 sedangkan gambar pilar dan diagram gaya yang bekerja pada pilar dapat dilihat pada Gambar 4.62 dan Gambar 4.63.

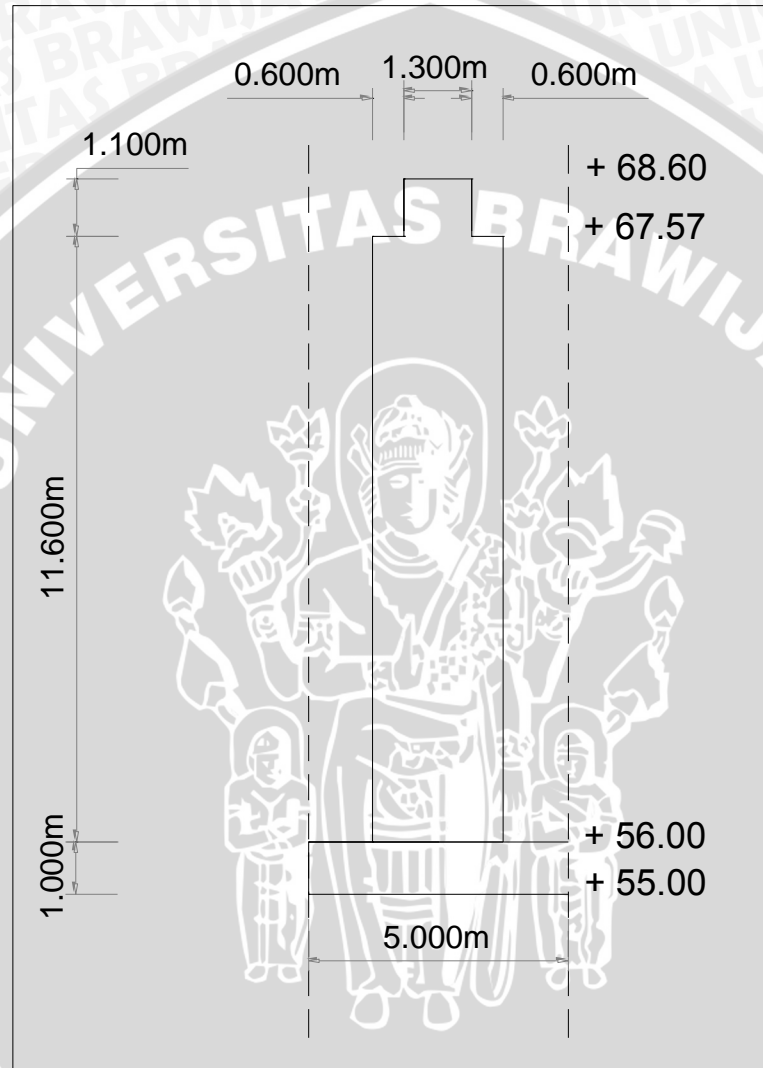

Gambar 4.62. Pilar II Kondisi Muka Air Banjir Gempa (Tampak Depan)

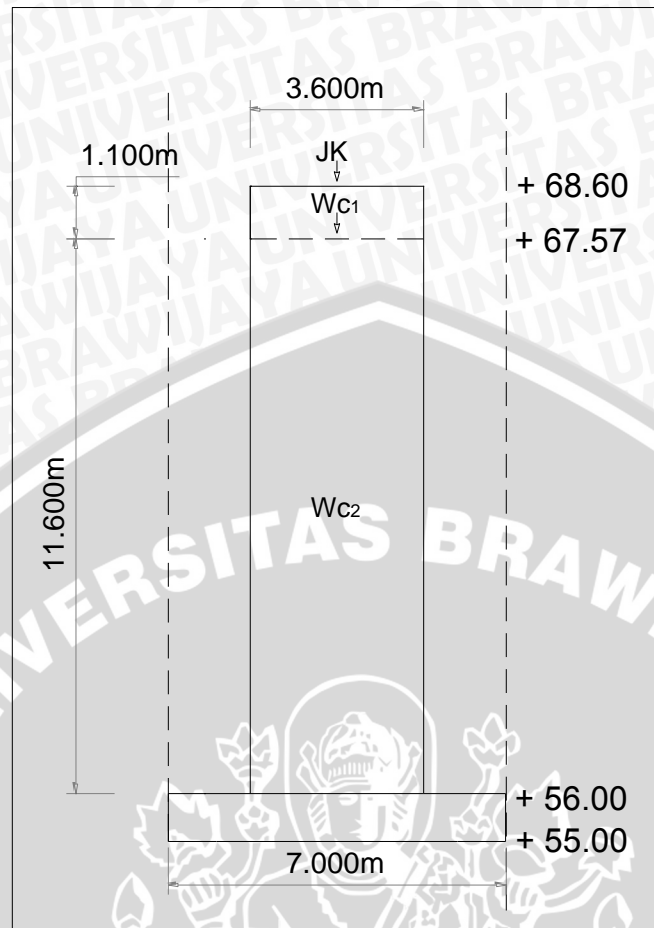

Gambar 4.63. Diagram Gaya Pada Pilar II Kondisi Muka Air Banjir Gempa (Tampak Samping)

Tabel 4.56. Gaya dan Momen Pilar pada Jembatan Kendaraan Akibat Gempa

Notasi	Nilai						Gaya		Lengan Momen	Momen
	Lebar (m)	Tinggi (m)	Panjang (m)	Ratio	$\gamma$ (t/m <sup>3</sup> )	Pv (ton)	Ph (ton)	y (m)	My (ton.m)	
	[1]	[2]	[3]	[4]	[5]	[6]	[7]	[8]	[9]	
W <sub>JK</sub>						= 58,674	8,801	13,150	115,733	
W <sub>c1</sub>	3,600	x 1,100	x 1,300	x 1,000	x 2,400	= 12,355	1,853	13,150	24,371	
W <sub>c2</sub>	3,600	x 11,600	x 2,500	x 1,000	x 2,400	= 250,560	37,584	6,800	255,571	
Total						$\Sigma V$ 321,589		$\Sigma Mh$	395,675	
							48,238			

Sumber: Hasil Perhitungan

$$\begin{aligned}
 P_u &= 1,200 \times \Sigma V \\
 &= 1,200 \times 321,589 \\
 &= 385,906 \text{ ton}
 \end{aligned}$$

$$\begin{aligned}
 M_u &= 1,200 \times \Sigma Mh \\
 &= 1,200 \times 395,675 \\
 &= 474,81 \text{ ton}
 \end{aligned}$$

Keterangan:

- [ 1 ] = lebar tiap bagian (m)
- [ 2 ] = tinggi tiap bagian (m)
- [ 3 ] = panjang konstruksi
- [ 4 ] = 1 digunakan untuk penampang persegi atau persegi panjang  
= 0,5 digunakan untuk penampang segitiga

- [ 5 ] = berat jenis beton bertulang =  $2,4 \text{ (t/m}^3\text{)}$   
 = berat jenis air =  $1,0 \text{ (t/m}^3\text{)}$
- [ 6 ] = gaya vertikal (ton)  
 = [ 1 ] \* [ 2 ] \* [ 3 ] \* [ 4 ] \* [ 5 ] (untuk bangunan dan timbunan )  
 nilai (+) untuk arah gaya ke bawah  
 nilai (-) untuk arah gaya ke atas
- [ 7 ] = gaya horizontal (ton)  
 = [ 6 ] \* kh , dengan kh = 0,15 (untuk berat bangunan)  
 =  $7/12 * [ 1 ] * [ 2 ] * [ 3 ] * [ 4 ] * [ 5 ] * kh$  (untuk tekanan air dinamis)  
 nilai (+) untuk arah gaya ke hilir  
 nilai (-) untuk arah gaya ke hulu
- [ 8 ] = lengan momen gaya berat konstruksi (m)
- [ 9 ] = momen (ton.m)  
 = [ 7 ] \* [ 8 ]

#### Data Pilar II :

- |                     |                |
|---------------------|----------------|
| 1. Lebar (h)        | = 3,60 m       |
| 2. Tebal (b)        | = 2,50 m       |
| 3. Tinggi           | = 12,70 m      |
| 4. Mutu Bahan       |                |
| Beton (fc')         | = 20,00 Mpa    |
| Baja (fy)           | = 240,00 Mpa   |
| 5. Beban pada Pilar |                |
| a. Pu               | = 3859,06 kN   |
| b. Mu               | = 4748,10 kN.m |

#### a. Kontrol Kelangsingan

Pilar diasumsikan sebagai kolom tanpa pengaku, dibagian atas dan bawahnya jepit-jepit, maka  $k = 1,00$  (Tabel 2.7). Kelangsingan kolom dapat dihitung menggunakan persamaan (2-94) dan persamaan (2-95) sebagai berikut:

dimana:

$$\begin{aligned} A &= b.h \\ &= 2,5 \times 3,6 \\ &= 9,00 \text{ m}^2 \end{aligned}$$

$$\begin{aligned}
 I &= \frac{1}{12} \cdot b \cdot h^3 \\
 &= \frac{1}{12} \cdot 2,5 \cdot (3,6)^3 \\
 &= 9,720 \text{ m}^4
 \end{aligned}$$

$$\begin{aligned}
 r &= \sqrt{\frac{I}{A}} \\
 &= \sqrt{\frac{9,720}{10,00}} = 1,039 \text{ m}
 \end{aligned}$$

$$k \frac{\lambda_{n,k}}{r} < 22$$

$$1,0 \frac{12,70}{1,039} < 22$$

$$12,221 < 22 \text{ (Termasuk Kolom Pendek)}$$

b. Luas Penampang Pilar

$$\begin{aligned}
 A_{gr} &= \text{Lebar} \times \text{Tebal} \\
 &= 3,60 \times 2,50 \\
 &= 9,00 \text{ m}^2 \\
 &= 9 \cdot 10^6 \text{ mm}^2
 \end{aligned}$$

c. Tulangan Kolom

Pada sumbu vertikal

$$\begin{aligned}
 \frac{P_u}{\phi \cdot A_{gr} \cdot 0,85 \cdot f_c'} &= \frac{3859,06 \cdot 10^3}{0,65 \cdot 9 \cdot 10^6 \cdot 0,85 \cdot 20,00} \\
 &= 0,039 < 0,10
 \end{aligned}$$

Ø ditingkatkan menjadi 0,80 maka:

$$\begin{aligned}
 \frac{P_u}{\phi \cdot A_{gr} \cdot 0,85 \cdot f_c'} &= \frac{3859,06 \cdot 10^3}{0,80 \cdot 10^7 \cdot 0,85 \cdot 20,00} \\
 &= 0,032 < 0,10
 \end{aligned}$$

$$\begin{aligned}
 e_t &= \frac{M_u}{P_u} \\
 &= \frac{4748,10}{3859,06} \\
 &= 1,230 \text{ m}
 \end{aligned}$$

$$e_t/h = 1230,38 / 3600 = 0,34$$

Pada sumbu horizontal

$$\begin{aligned}
 \frac{P_u}{\phi \cdot A_{gr} \cdot 0,85 \cdot f_c'} \left( \frac{e_t}{h} \right) &= 0,032 \cdot 0,34 \\
 &= 0,0108
 \end{aligned}$$

Dengan  $d'/h = 1000/3600 = 0,28$  diambil  $d'/h = 0,10$

Berdasarkan grafik pada Gambar 2.14, maka diperoleh  $r = 0,0045$  dan  $\beta = 0,80$

$$\begin{aligned}\rho &= \beta \cdot r \\ &= 0,80 \cdot 0,0045 \\ &= 0,0036\end{aligned}$$

$$\begin{aligned}A_g \text{ total} &= \rho \cdot A_g r \\ &= 0,0036 \cdot 9 \cdot 10^6 \\ &= 32400 \text{ mm}^2 \\ &= 324 \text{ cm}^2\end{aligned}$$

Dipakai: Tulangan utama 117 D 19-100  $\text{mm}^2 = 33218,227 \text{ mm}^2 > 32400 \text{ mm}^2$

d. Begel pada Kolom

Tebal selimut beton ( $d_s$ ) = 100 mm

$$\begin{aligned}d &= h - d_s \\ &= 3600 - 100 \\ &= 3500 \text{ mm}\end{aligned}$$

1. Gaya geser perlu kolom ( $V_{u,k}$ )

$$\begin{aligned}V_{u,k} &= \frac{M_{u2} - M_{u1}}{\lambda_k} \\ &= \frac{4748,10}{12,70} \\ &= 373,87 \text{ kN} \\ &= 373866,44 \text{ N}\end{aligned}$$

2. Gaya geser yang ditahan oleh beton ( $V_c$ )

$$\begin{aligned}V_c &= \left(1 + \frac{N_{u,k}}{14 \cdot A_g}\right) \frac{\sqrt{f_c'}}{6} \cdot b \cdot d \\ &= \left(1 + \frac{3859,06}{14 \cdot 2500 \cdot 3600}\right) \frac{\sqrt{20}}{6} \cdot 2500 \cdot 3500 \\ &= 6522064,683 \text{ N}\end{aligned}$$

a. Gaya geser yang ditahan oleh beton ( $V_s$ ) dan  $V_{s,\text{maks}}$

$$\begin{aligned}V_s &= \frac{V_u - \phi \cdot V_c}{\phi} \text{ dengan } \phi = 0,75 \\ &= \frac{373866,44 - 0,75 \cdot 6522064,683}{0,75} \text{ dengan } \phi = 0,75 \\ &= -6023576,1 \text{ N}\end{aligned}$$

$$\begin{aligned}V_{s,\text{maks}} &= \frac{2}{3} \cdot \sqrt{f_c'} \cdot b \cdot d \\ &= \frac{2}{3} \cdot \sqrt{20} \cdot 2500 \cdot 3500 = 26087459,74 \text{ N}, \text{ syarat } V_s \leq V_{s,\text{maks}} \dots \text{OK}\end{aligned}$$

3. Luas begel perlu ( $A_{v,u}$ ) untuk setiap panjang kolom  $S = 1000$  mm, dengan memilih yang terbesar dari nilai  $A_v$  berikut:

$$\begin{aligned} A_v &= \frac{V_s \cdot S}{f_y \cdot d} \\ &= \frac{-6023576,1 \cdot 1000}{240 \cdot 3500} \\ &= -7170,92 \text{ mm}^2 \end{aligned}$$

$$\begin{aligned} A_v &= \frac{b \cdot s}{3 \cdot f_y} \\ &= \frac{2500 \cdot 1000}{3 \cdot 240} = 3472,2 \text{ mm}^2 \end{aligned}$$

$$\begin{aligned} A_v &= \frac{75 \sqrt{f_c'} \cdot b \cdot S}{1200 \cdot f_y} \\ &= \frac{75 \sqrt{20'} \cdot 2500 \cdot 1000}{1200 \cdot 240} \\ &= 2911,55 \text{ mm}^2 \end{aligned}$$

Dipilih yang paling besar, jadi  $A_{v,u} = 3472,2 \text{ mm}^2$

Digunakan begel 2 kaki dengan  $d_p = 10$  mm

4. Jarak antar begel

$$\begin{aligned} s &= \frac{\frac{n}{4} \pi \cdot d_p^2 \cdot S}{A_{v,u}} \\ &= \frac{\frac{2}{4} \pi \cdot 10^2 \cdot 1000}{3472,2} \\ &= 45,24 \text{ mm} \end{aligned}$$

Kontrol jarak:

$$s \leq 16D = 304 \text{ mm}$$

$$s \leq 48 \cdot d_p = 480 \text{ mm}$$

$$s \leq d/2 = 1750 \text{ mm}$$

$$s \leq 600 \text{ mm}$$

Dipakai nilai terkecil dan dibulatkan ke bawah, yaitu  $s = 45 \text{ mm} \leq 45,24 \text{ mm}$

(Dibaca: "Begel 2 kaki berdiameter polos 10 mm dan berjarak 45 mm")





## e. Telapak Pondasi

Gaya dan momen yang bekerja pada pondasi telapak dapat dilihat pada Tabel. 4.57

**Tabel 4.57. Gaya dan Momen Pondasi Telapak Akibat Gempa**

Notasi	Nilai						Gaya		Lengan Momen	Momen	
	Lebar (m)		Tinggi (m)		Panjang (m)	Ratio	$\gamma$ (t/m <sup>3</sup> )	Pv (ton)	Ph (ton)	y (m)	My (ton.m)
	[1]		[2]		[3]	[4]	[5]	[6]	[7]	[8]	[9]
W <sub>JK</sub>								= 58,674	8,801	13,150	115,733
W <sub>c1</sub>	3,600	x	1,100	x	1,300	x	1,000	x	2,400		
								= 12,355	1,853	13,150	24,371
W <sub>c2</sub>	3,600	x	11,600	x	2,500	x	1,000	x	2,400		
								= 250,560	37,584	6,800	255,571
W <sub>c3</sub>	7,000	x	1,000	x	5,000	x	1,000	x	2,400		
								= 84,000	12,600	0,500	6,300
Total								$\Sigma V$			
								$\Sigma H$	60,838	$\Sigma Mh$	401,975

Sumber: Hasil Perhitungan

	Pu	=	1,200	x	Σ V		Mu	=	1,200	x	Σ Mh
					= 405,589						= 401,975
					= 486,706 ton						= 482,37 ton

## Keterangan:

- [ 1 ] = lebar tiap bagian (m)
- [ 2 ] = tinggi tiap bagian (m)
- [ 3 ] = panjang konstruksi
- [ 4 ] = 1 digunakan untuk penampang persegi atau persegi panjang  
= 0,5 digunakan untuk penampang segitiga
- [ 5 ] = berat jenis beton bertulang = 2,4 (t/m<sup>3</sup>)  
= berat jenis air = 1,0 (t/m<sup>3</sup>)
- [ 6 ] = gaya vertikal (ton)  
= [ 1 ] \* [ 2 ] \* [ 3 ] \* [ 4 ] \* [ 5 ] (untuk bangunan dan timbunan )  
nilai (+) untuk arah gaya ke bawah  
nilai (-) untuk arah gaya ke atas
- [ 7 ] = gaya horizontal (ton)  
= [ 6 ] \* kh , dengan kh = 0,15 (untuk berat bangunan)  
= 7/12 \* [ 1 ] \* [ 2 ] \* [ 3 ] \* [ 4 ] \* [ 5 ] \* kh (untuk tekanan air dinamis)  
nilai (+) untuk arah gaya ke hilir  
nilai (-) untuk arah gaya ke hulu
- [ 8 ] = lengan momen gaya berat konstruksi (m)
- [ 9 ] = momen (ton.m)  
= [ 7 ] \* [ 8 ]

Data pondasi telapak:

1. Lebar (B) = 5,00 m
2. Panjang (L) = 7,00 m
3. Tebal (h) = 1,00 m
4. Panjang Kolom (hk) = 3,60 m
5. Lebar Kolom (bk) = 2,50 m
6. Tebal Selimut (ds) = 0,10 m
7. Mutu Bahan

$$\text{Beton (fc')} = 20,00 \text{ Mpa}$$

$$\text{Baja (fy)} = 240 \text{ Mpa}$$

8. Beban pada Pondasi Telapak

$$P_u = 4867,06 \text{ kN}$$

$$M_u = 4823,70 \text{ kNm}$$

Langkah perhitungan pondasi telapak adalah sebagai berikut:

1. Menghitung tegangan

$$\begin{aligned} \sigma_{\max, \min} &= \frac{P_{u,k}}{B.L} \pm \frac{M_{u,x}}{\frac{1}{6}.B.L^2} \\ &= \frac{4867,06}{5,00.7,00} \pm \frac{4823,70}{\frac{1}{6}.5,0.7,0^2} \end{aligned}$$

$$\begin{aligned} \sigma_{\max} &= 139,06 + 118,13 \\ &= 257,19 \text{ kN/m}^2 \end{aligned}$$

$$\begin{aligned} \sigma_{\min} &= 139,06 - 118,13 \\ &= 20,93 \text{ kN/m}^2 \end{aligned}$$

2. Kontrol Tegangan Geser 1 Arah

$$d_s = 100 \text{ mm}$$

$$\begin{aligned} d &= h - d_s \\ &= 1000 - 100 \\ &= 900 \text{ mm} \end{aligned}$$

$$\begin{aligned} a &= \frac{L}{2} - \frac{hk}{2} - d \\ &= \frac{7000}{2} - \frac{3600}{2} - 900 = 800 \text{ mm} = 0,80 \text{ m} \end{aligned}$$

$$\begin{aligned} \sigma_a &= \sigma_{\min} + \frac{(L-a).(\sigma_{\max} - \sigma_{\min})}{L} \\ &= 20,93 + \frac{(7000-800).(257,19-20,93)}{7000} = 230,19 \text{ kN/mm}^2 \end{aligned}$$

Gaya tekan ke atas ( $V_u$ )

$$\begin{aligned} V_u &= a.B \left( \frac{\sigma_{\text{maks}} + \sigma_a}{2} \right) \\ &= 0,80.5,0 \left( \frac{257,19 + 230,19}{2} \right) \\ &= 974,76 \text{ kN} \end{aligned}$$

Gaya geser yang dapat ditahan oleh beton ( $\phi V_c$ ) dengan  $\phi = 0,75$

$$\begin{aligned} V_c &= \frac{\sqrt{f_c'}}{6} B.d.\phi \\ &= \frac{\sqrt{20}}{6} 5000.900.0,75 \\ &= 2515,58 \text{ kN} \end{aligned}$$

Kontrol  $V_u = 974,76 \text{ kN} \leq \phi.V_c = 2515,58 \text{ kN} \dots \text{OK}$

### 3. Kontrol Tegangan Geser 2 Arah (Geser Pons)

$$(b + d) = (2500 + 900) = 3400 \text{ mm} = 3,40 \text{ m}$$

$$(h + d) = (3600 + 900) = 4500 \text{ mm} = 4,50 \text{ m}$$

a. Gaya Tekan ke atas (Geser Pons)

$$\begin{aligned} V_u &= \{B.L - (b+d)(h+d)\} \left( \frac{\sigma_{\text{maks}} + \sigma_{\text{min}}}{L} \right) \\ &= \{7000.5000 - 3400.4500\} \left( \frac{257,19 + 20,93}{7000} \right) \\ &= 2739,46 \text{ kN} \end{aligned}$$

$$s = \frac{hk}{bk} = \frac{3,60}{2,50} = 1,44$$

$$\begin{aligned} b_o &= 2\{(bk+d) + (hk+d)\} \\ &= 2\{(2500+900) + (3600+900)\} \\ &= 15800 \text{ mm} \end{aligned}$$

b. Gaya geser yang ditahan beton ( $\phi V_c$ )

$$\begin{aligned} V_c &= \left( 1 + \frac{2}{\beta_c} \right) \frac{\sqrt{f_c'} b_o d}{6} \\ &= \left( 1 + \frac{2}{1,44} \right) \frac{\sqrt{20}.15800.900}{6} \\ &= 25319743,07 \text{ N} \\ &= 25319,74 \text{ kN} \end{aligned}$$

$$\begin{aligned} V_c &= \left( 2 + \frac{\alpha_s d}{b_o} \right) \frac{\sqrt{f_c'} b_o d}{12} \\ &= \left( 2 + \frac{30.900}{15800} \right) \frac{\sqrt{20}.15800.900}{12} \\ &= 19655037,52 \text{ N} = 19655,04 \text{ kN} \end{aligned}$$

$$\begin{aligned}
 V_c &= \left(\frac{1}{3}\right) \sqrt{f_c'} \cdot b_o \cdot d \\
 &= \left(\frac{1}{3}\right) \sqrt{20'} \cdot 15800 \cdot 900 \cdot 4 \\
 &= 21197924,4 \text{ N} \\
 &= 21297,92 \text{ kN}
 \end{aligned}$$

Dipilih gaya geser yang terkecil yaitu  $V_c = 19655,04 \text{ kN}$

Kontrol:  $V_u = 4928,92 \text{ kN} \leq \phi V_c = 0,75 \cdot 19655,04 \text{ kN}$

$$V_u = 2739,46 \text{ kN} \leq \phi V_c = 14741,3 \text{ kN} \dots \text{OK}$$

#### 4. Tulangan Pondasi

##### a. Tulangan arah x-x

$$\begin{aligned}
 x &= \frac{L}{2} - \frac{h_k}{2} \\
 &= \frac{7,00}{2} - \frac{3,60}{2} = 1,70 \text{ m}
 \end{aligned}$$

Menghitung  $\sigma_x$  = tegangan tanah pada jarak x

$$\begin{aligned}
 \sigma_x &= \sigma_{\min} + \frac{L-x}{L} (\sigma_{\max} - \sigma_{\min}) \\
 &= 20,93 + \frac{7,00-1,70}{7,00} (257,19 - 20,93) \\
 &= 199,81 \text{ kN/m}^2
 \end{aligned}$$

Momen yang terjadi ( $M_u$ )

$$\begin{aligned}
 M_u &= \frac{1}{2} \cdot \sigma_x \cdot x^2 + \frac{1}{3} (\sigma_{\max} - \sigma_x) x^3 \\
 &= \frac{1}{2} \cdot 199,81 \cdot 1,70^2 + \frac{1}{3} (257,19 - 199,81) 1,70^3 \\
 &= 344,00 \text{ kNm}
 \end{aligned}$$

Faktor momen pikul ( $K$ ) dan ( $K_{\max}$ )

$$\begin{aligned}
 K &= M_u / (\phi \cdot b \cdot d^2) \\
 &= 344,00 \cdot 10^6 / (0,80 \cdot 1000 \cdot 900^2) \\
 &= 0,531 \text{ Mpa}
 \end{aligned}$$

$$\begin{aligned}
 K_{\max} &= \frac{382,5 \cdot \beta_1 \cdot f_c' \cdot (600 + f_y - 225 \cdot \beta_1)}{(600 + f_y)^2} \\
 &= \frac{382,5 \cdot 0,85 \cdot 20 \cdot (600 + 240 - 225 \cdot 240)}{(600 + 240)^2} \\
 &= 5,979 \text{ Mpa}
 \end{aligned}$$

Tinggi blok tegangan beton tekan persegi ekuivalen (a)

$$\begin{aligned}
 a &= \left(1 - \sqrt{1 - \frac{2K}{0,85 \cdot f_c'}}\right) d \\
 &= \left(1 - \sqrt{1 - \frac{2 \cdot 0,531}{0,85 \cdot 20}}\right) 900 = 28,56 \text{ mm}
 \end{aligned}$$

Luas tulangan diperlukan ( $A_s, u$ )

$$\begin{aligned} A_{s,u} &= \frac{0,85 \cdot f_c' \cdot a \cdot b}{f_y} \\ &= \frac{0,85 \cdot 20 \cdot 28,56 \cdot 1000}{240} \\ &= 2022,852 \text{ mm}^2 \end{aligned}$$

Tulangan yang digunakan

D19 – 125

$$A_s = 2268,23 \text{ mm}^2 > A_{s,u} = 2022,852 \text{ mm}^2$$

b. Tulangan arah y-y

$$\begin{aligned} x &= \frac{B}{2} - \frac{b_k}{2} \\ &= \frac{5,00}{2} - \frac{2,50}{2} \\ &= 1,25 \text{ m} \end{aligned}$$

Momen yang terjadi ( $M_u$ )

$$\begin{aligned} M_u &= \frac{1}{2} \cdot \sigma_{\text{maks}} \cdot x^2 \\ &= \frac{1}{2} \cdot 257,19 \cdot 1,25^2 \\ &= 200,93 \text{ kNm} \end{aligned}$$

Faktor momen pikul ( $K$ ) dan ( $K_{\text{maks}}$ )

$$\begin{aligned} K &= M_u / (\phi \cdot b \cdot d^2) \\ &= 200,93 \cdot 10^6 / (0,80 \cdot 1000 \cdot 900^2) \\ &= 0,310 \text{ Mpa} \end{aligned}$$

$$\begin{aligned} K_{\text{maks}} &= \frac{382,5 \cdot \beta_1 \cdot f_c' \cdot (600 + f_y - 225 \cdot \beta_1)}{(600 + f_y)^2} \\ &= \frac{382,5 \cdot 0,85 \cdot 20 \cdot (600 + 240 - 225 \cdot 240)}{(600 + 240)^2} = 5,979 \text{ Mpa} \end{aligned}$$

Tinggi blok tegangan beton tekan persegi ekuivalen ( $a$ )

$$\begin{aligned} a &= \left( 1 - \sqrt{1 - \frac{2K}{0,85 \cdot f_c'}} \right) d \\ &= \left( 1 - \sqrt{1 - \frac{2 \cdot 0,310}{0,85 \cdot 20}} \right) 900 \\ &= 16,57 \text{ mm} \end{aligned}$$

Luas tulangan diperlukan ( $A_{s,u}$ )

$$\begin{aligned} A_{s,u} &= \frac{0,85 \cdot f_c' \cdot a \cdot b}{f_y} \\ &= \frac{0,85 \cdot 20 \cdot 16,57 \cdot 1000}{240} \\ &= 1173,59 \text{ mm}^2 \end{aligned}$$

Untuk jalur pusat selebar  $B = 5,00 \text{ m}$

$$\begin{aligned} A_{s,\text{pusat}} &= (2 \cdot B \cdot A_{s,u}) / (L + B) \\ &= (2 \cdot 5,00 \cdot 1173,59) / (7,00 + 5,00) \\ &= 977,99 \text{ mm}^2 \end{aligned}$$

Tulangan yang digunakan

D19 – 250

$$A_s = 1134,11 \text{ mm}^2 > A_{s,u} = 977,99 \text{ mm}^2$$

Untuk jalur tepi (diluar jalur pusat)

$$\begin{aligned} A_{s,\text{tepi}} &= A_{s,u} - A_{s,\text{pusat}} \\ &= 1173,59 - 1134,11 \\ &= 39,48 \text{ mm}^2 \end{aligned}$$

Tulangan yang digunakan

D19 – 450

$$A_s = 630,06 \text{ mm}^2 > A_{s,u} = 39,48 \text{ mm}^2$$

Detail Gambar Penulangan Pilar II dapat dilihat pada Gambar 4.64 sampai 4.66.

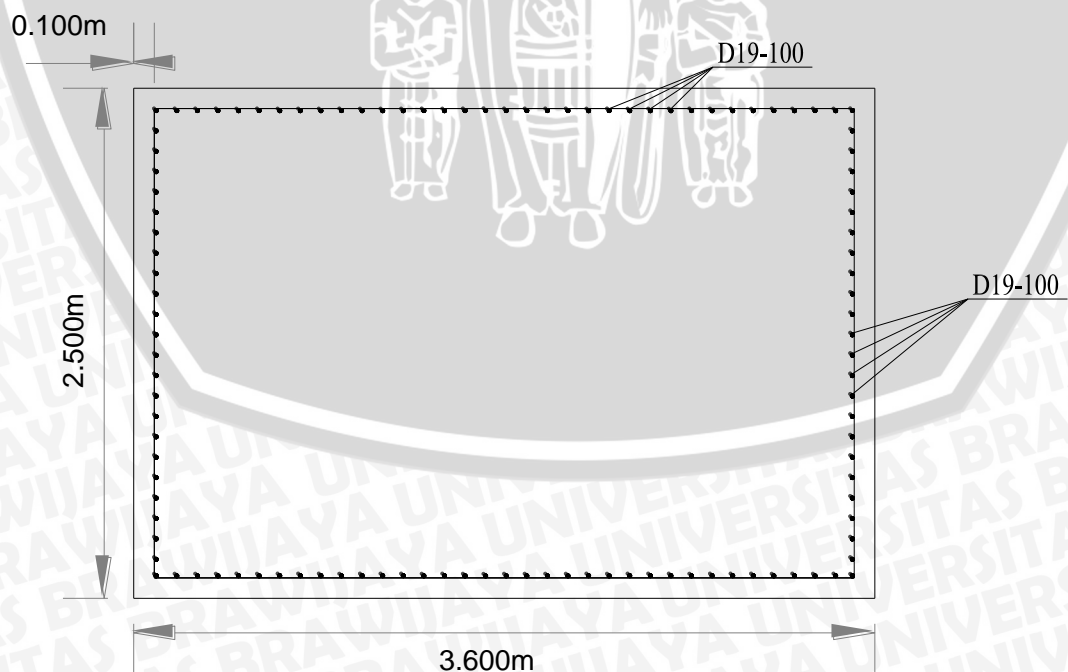

**Gambar 4.64. Tulangan Pilar II**

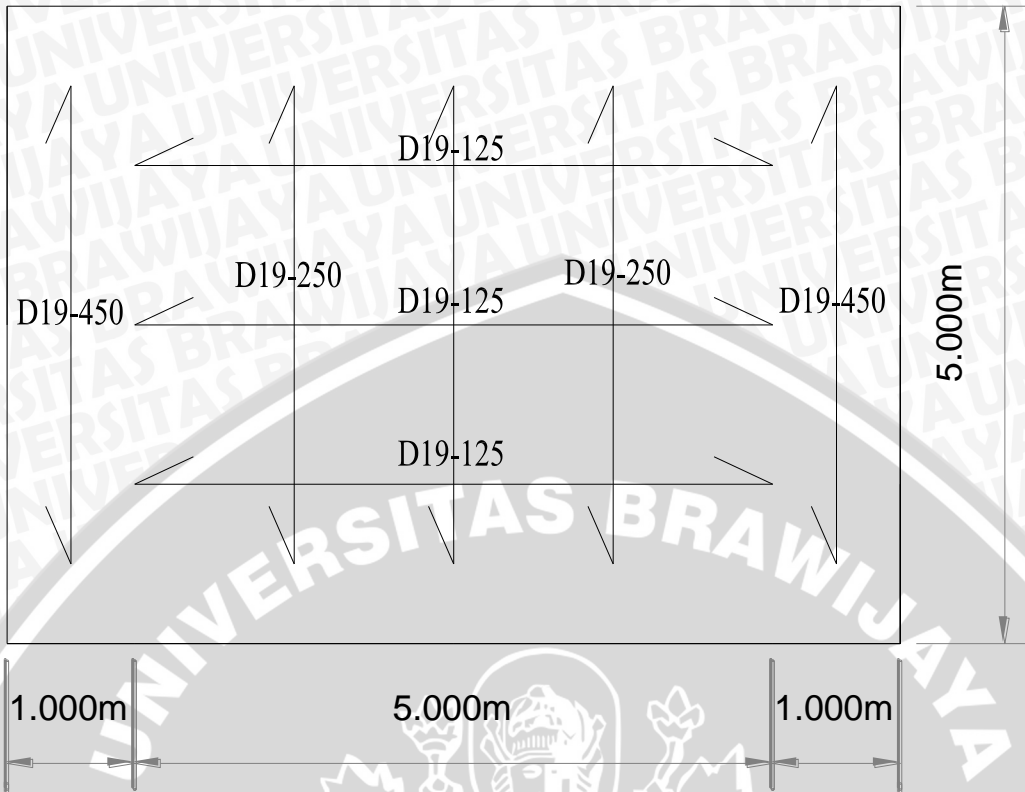

**Gambar 4.65. Pondasi Telapak Pilar II**

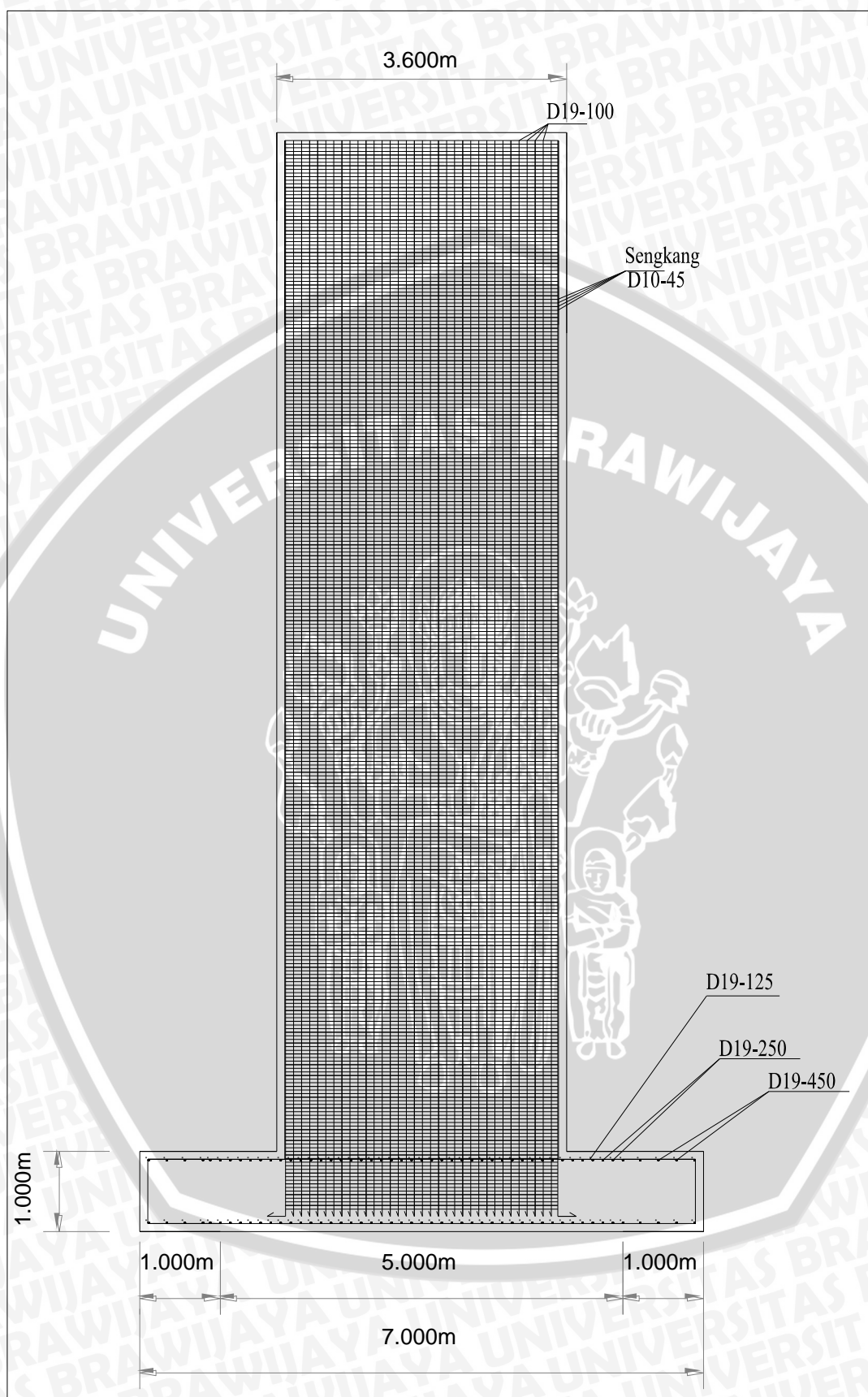

Gambar 4.66. Tulangan Pilar II



#### 4.5.2.3. Pilar III, Pilar IV dan Pilar V

Perencanaan penulangan pada tubuh pilar berdasarkan luas penampang tubuh pilar serta momen lentur dan gaya tekan sentris akibat berat struktur di atasnya. Gambar diagram gaya yang bekerja pada pilar dapat dilihat pada Gambar 4.67.

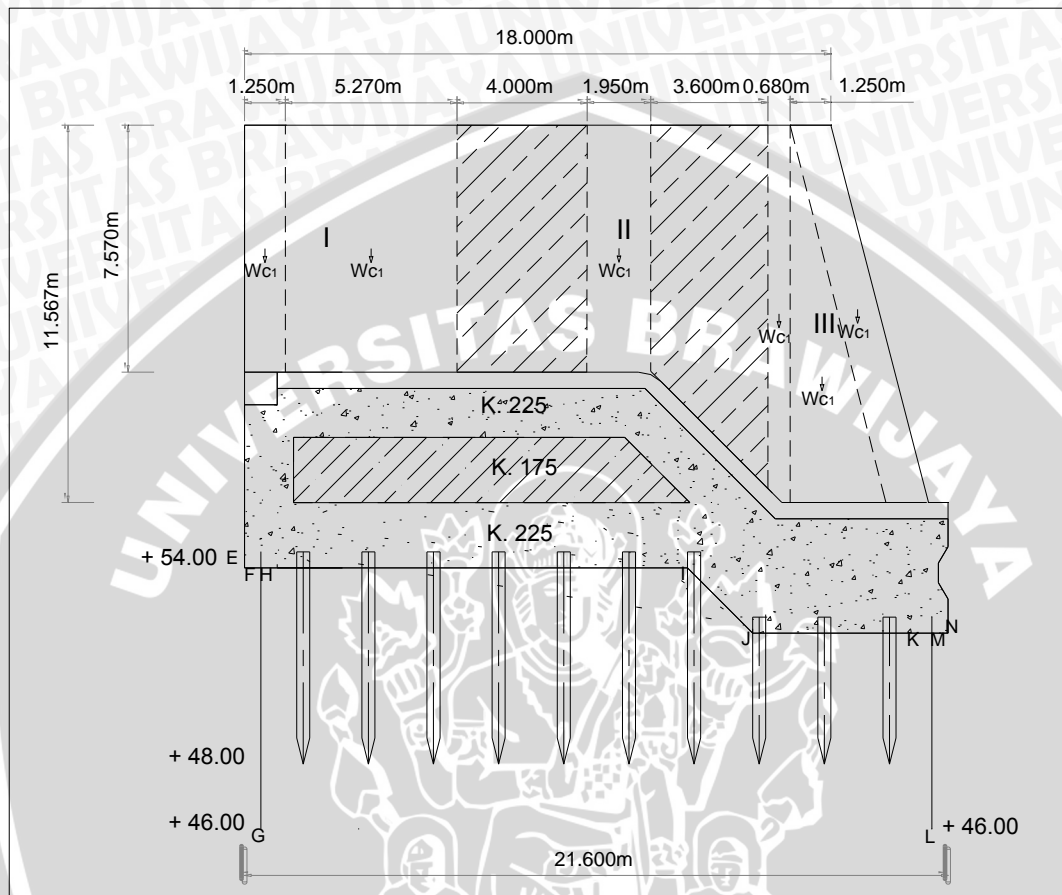

**Gambar 4.67. Diagram Gaya Pada Pilar**

Keterangan:

- I = Pilar III
- II = Pilar I (menahan beban rumah operasi pintu dan jembatan kendaraan)
- III = Pilar IV
- IV = Pilar II (menahan beban jembatan kendaraan)
- V = Pilar V

##### 4.5.2.3.1. Pilar III

Perencanaan tulangan pada pilar ini menggunakan tulangan praktis yang berfungsi untuk menghindari keretakan pilar akibat susut beton. Pilar ini hanya menahan beban sendiri dikarenakan beban rumah operasional pintu, jembatan pelayanan dan jembatan kendaraan sudah dibebankan seluruhnya pada pilar I dan pilar II. Perhitungan gaya dan momen pilar dapat dilihat pada Tabel 4.58.

Tabel 4.58. Gaya dan Momen Pilar III

Notasi	Nilai									Gaya		Lengan Momen	Momen			
	Lebar (m)	Tinggi (m)	Panjang (m)	Ratio	$\gamma$ (t/m <sup>3</sup> )					Pv (ton)	Ph (ton)	y (m)	My (ton.m)			
	[1]	[2]	[3]	[4]	[5]					[6]	[7]	[8]	[9]			
Wc1	1,250	x	7,570	x	1,250	x	0,500	x	2,400	x	$\pi$	=	44,591	6,689	4,785	32,005
Wc2	5,270	x	7,570	x	2,500	x	1,000	x	2,400			=	239,363	35,905	4,785	171,803
Total										$\Sigma V$			283,954		$\Sigma Mh$	203,808
										$\Sigma H$			42,593			

Sumber: Hasil Perhitungan

Pu	=	1,200	x	$\Sigma V$		Mu	=	1,200	x	$\Sigma Mh$
	=	1,200	x	283,954			=	1,200	x	203,808
	=	340,745	ton				=	244,57	ton	

Keterangan:

- [ 1 ] = lebar tiap bagian (m)
- [ 2 ] = tinggi tiap bagian (m)
- [ 3 ] = panjang konstruksi
- [ 4 ] = 1 digunakan untuk penampang persegi atau persegi panjang  
= 0,5 digunakan untuk penampang segitiga
- [ 5 ] = berat jenis beton bertulang = 2,4 (t/m<sup>3</sup>)  
= berat jenis air = 1,0 (t/m<sup>3</sup>)
- [ 6 ] = gaya vertikal (ton)  
= [ 1 ] \* [ 2 ] \* [ 3 ] \* [ 4 ] \* [ 5 ] (untuk bangunan dan timbunan)  
nilai (+) untuk arah gaya ke bawah  
nilai (-) untuk arah gaya ke atas
- [ 7 ] = gaya horizontal (ton)  
= [ 6 ] \* kh , dengan kh = 0,15 (untuk berat bangunan)  
= 7/12 \* [ 1 ] \* [ 2 ] \* [ 3 ] \* [ 4 ] \* [ 5 ] \* kh (untuk tekanan air dinamis)  
nilai (+) untuk arah gaya ke hilir  
nilai (-) untuk arah gaya ke hulu
- [ 8 ] = lengan momen gaya berat konstruksi (m)
- [ 9 ] = momen (ton.m)  
= [ 7 ] \* [ 8 ]

Data Pilar III :

1. Lebar (h) = 6,52 m
2. Tebal (b) = 2,50 m
3. Tinggi = 7,57 m
4. Mutu Bahan  
Beton (fc') = 20,00 Mpa

$$\text{Baja } (f_y) = 240,00 \text{ Mpa}$$

#### 5. Beban pada Pilar

$$\text{a. Pu} = 3407,45 \text{ kN}$$

$$\text{b. Mu} = 2445,70 \text{ kN.m}$$

#### a. Kontrol Kelangsingan

Pilar diasumsikan sebagai kolom tanpa pengaku, dibagian atas dan bawahnya jepit-jepit, maka  $k = 1,00$  (Tabel 2.7). Kelangsingan kolom dapat dihitung menggunakan persamaan (2-94) dan persamaan (2-95) sebagai berikut:

dimana:

$$A = (\text{Lebar} \times \text{tebal})$$

$$= 6,52 \times 2,50$$

$$= 16,30 \text{ m}^2$$

$$I = \frac{1}{12} \cdot b \cdot h^3$$

$$= \frac{1}{12} \cdot 2,5 \cdot (6,52)^3$$

$$= 57,743 \text{ m}^4$$

$$r = \sqrt{\frac{I}{A}}$$

$$= \sqrt{\frac{57,743}{16,30}} = 1,882 \text{ m}$$

$$k \frac{\lambda_{n,k}}{r} < 22$$

$$1,0 \frac{7,57}{1,882} < 22$$

$$4,02 < 22 \text{ (Termasuk Kolom Pendek)}$$

#### b. Luas Penampang Pilar

$$\text{Agr} = (\text{Lebar} \times \text{tebal}) + (1/2 \cdot \pi \cdot r^2)$$

$$= (2,5 \times 3,6) + (1/2 \cdot \pi \cdot 1,25^2)$$

$$= 15,629 \text{ m}^2$$

$$= 1,56 \cdot 10^7 \text{ mm}^2$$

#### c. Tulangan Kolom

Pada sumbu vertikal

$$\frac{\text{Pu}}{\phi \cdot \text{Agr} \cdot 0,85 \cdot f_c'} = \frac{3407,45 \cdot 10^3}{0,65 \cdot 1,6 \cdot 10^7 \cdot 0,85 \cdot 20,00}$$

$$= 0,020 < 0,10$$

Ø ditingkatkan menjadi 0,80 maka:

$$\frac{P_u}{\phi \cdot \text{Agr} \cdot 0,85 \cdot f_c'} = \frac{3407,45 \cdot 10^3}{0,65 \cdot 1,5 \cdot 10^7 \cdot 0,85 \cdot 20,00}$$

$$= 0,016 < 0,10$$

$$\begin{aligned} \text{et} &= \frac{M_u}{P_u} \\ &= \frac{2445,70}{3407,45} \end{aligned}$$

$$= 0,718 \text{ m}$$

$$\text{et/h} = 717,75/6520 = 0,11$$

Pada sumbu horizontal

$$\frac{P_u}{\phi \cdot \text{Agr} \cdot 0,85 \cdot f_c'} \left( \frac{\text{et}}{h} \right) = 0,015 \cdot 0,11$$

$$= 0,00176$$

Dengan  $d'/h = 100/6520 = 0,02$  diambil  $d'/h = 0,02$

Berdasarkan grafik pada Gambar 2.14, maka diperoleh  $r = 0,004$  dan  $\beta = 0,80$

$$\begin{aligned} \rho &= \beta \cdot r \\ &= 0,80 \cdot 0,0004 \\ &= 0,0003 \end{aligned}$$

$$\begin{aligned} \text{Ag total} &= \rho \cdot \text{Agr} \\ &= 0,0003 \cdot 1,6 \cdot 10^7 \\ &= 5001,4 \text{ mm}^2 \\ &= 50,014 \text{ cm}^2 \end{aligned}$$

Dipakai: Tulangan utama 70D 12 -  $250 \text{ mm}^2 = 7965,9 \text{ mm}^2 > 5001,4 \text{ mm}^2$

d. Begel pada Kolom

Tebal selimut beton ( $d_s$ ) = 100 mm

$$\begin{aligned} d &= h - d_s \\ &= 6520 - 100 \\ &= 6420 \text{ mm} \end{aligned}$$

1. Gaya geser perlu kolom ( $V_{u,k}$ )

$$\begin{aligned} V_{u,k} &= \frac{M_{u2} - M_{u1}}{\lambda k} \\ &= \frac{2445,70}{7,57} \\ &= 211,38 \text{ kN} \end{aligned}$$

$$= 211382,81 \text{ N}$$

- a. Gaya geser yang ditahan oleh beton ( $V_c$ )

$$\begin{aligned} V_c &= \left(1 + \frac{N_{u,k}}{14.A_g}\right) \frac{\sqrt{f_c'}}{6} \cdot b \cdot d \\ &= \left(1 + \frac{3407,45 \cdot 10^3}{14 \cdot 2500 \cdot 6520}\right) \frac{\sqrt{20}}{6} \cdot 2500 \cdot 6420 \\ &= 12141593,81 \text{ N} \end{aligned}$$

- b. Gaya geser yang ditahan oleh beton ( $V_s$ ) dan  $V_{s,max}$

$$\begin{aligned} V_s &= \frac{V_u - \phi \cdot V_c}{\phi} \text{ dengan } \phi = 0,75 \\ &= \frac{211382,81 - 0,75 \cdot 12141593,81}{0,75} \text{ dengan } \phi = 0,75 \\ &= -11859749,3 \text{ N} \end{aligned}$$

$$\begin{aligned} V_{s,max} &= \frac{2}{3} \cdot \sqrt{f_c'} \cdot b \cdot d \\ &= \frac{2}{3} \cdot \sqrt{20} \cdot 2500 \cdot 6420 \\ &= 47851854,72 \text{ N}, \text{ syarat } V_s \leq V_{s,max} \dots \text{ OK} \end{aligned}$$

- c. Luas begel perlu ( $A_{v,u}$ ) untuk setiap panjang kolom  $S = 1000 \text{ mm}$ , dengan memilih yang terbesar dari nilai  $A_v$  berikut:

$$\begin{aligned} A_v &= \frac{V_s \cdot S}{f_y \cdot d} \\ &= \frac{-11862150 \cdot 1000}{240 \cdot 6420} \\ &= -7697,14 \text{ mm}^2 \end{aligned}$$

$$\begin{aligned} A_v &= \frac{b \cdot S}{3 \cdot f_y} \\ &= \frac{2500 \cdot 1000}{3 \cdot 240} = 3472,2 \text{ mm}^2 \end{aligned}$$

$$\begin{aligned} A_v &= \frac{75 \sqrt{f_c'} \cdot b \cdot S}{1200 \cdot f_y} \\ &= \frac{75 \sqrt{20} \cdot 2500 \cdot 1000}{1200 \cdot 240} \\ &= 2911,55 \text{ mm}^2 \end{aligned}$$

Dipilih yang paling besar, jadi  $A_{v,u} = 3472,2 \text{ mm}^2$

Digunakan begel 2 kaki dengan  $d_p = 10 \text{ mm}$

- d. Jarak antar begel

$$\begin{aligned} s &= \frac{\frac{\pi}{4} \cdot d_p^2 \cdot S}{A_{v,u}} \\ &= \frac{\frac{\pi}{4} \cdot 10^2 \cdot 1000}{3472,2} = 45,24 \text{ mm} \end{aligned}$$

Kontrol jarak:

$$s \leq 16D = 192 \text{ mm}$$

$$s \leq 48.dp = 480 \text{ mm}$$

$$s \leq d/2 = 3210 \text{ mm}$$

$$s \leq 600 \text{ mm}$$

Dipakai nilai terkecil dan dibulatkan ke bawah, yaitu  $s = 45 \text{ mm} \leq 45,24 \text{ mm}$

(Dibaca: “Begel 2 kaki berdiameter polos 10 mm dan berjarak 45 mm”)

#### 4.5.2.3.2. Pilar IV

Perencanaan tulangan pada pilar ini menggunakan tulangan praktis yang berfungsi untuk menghindari keretakan pilar akibat susut beton. Pilar ini hanya menahan beban sendiri dikarenakan beban rumah operasional pintu, jembatan pelayanan dan jembatan kendaraan sudah dibebankan seluruhnya pada pilar I dan pilar II. Perhitungan gaya dan momen pilar dapat dilihat pada Tabel 4.59

**Tabel 4.59. Gaya dan Momen Pilar III**

Notasi	Nilai						Gaya		Lengan Momen	Momen				
	Lebar	Tinggi	Panjang	Ratio	$\gamma$		Pv	Ph	y	My				
	(m)	(m)	(m)		( $t/m^3$ )		(ton)	(ton)	(m)	(ton.m)				
	[1]	[2]	[3]	[4]	[5]		[6]	[7]	[8]	[9]				
Wca	1,950	x	7,570	x	2,500	x	1,000	x	2,400	=	88,569	13,285	4,785	63,570
Total							$\Sigma V$	88,569		$\Sigma Mh$	63,570			
Sumber: Hasil Perhitungan														
	Pu	=	1,200	x	$\Sigma V$				Mu	=	1,200	x	$\Sigma Mh$	
		=	1,200	x	88,569					=	1,200	x	63,570	
		=	106,283	ton						=	76,2845	ton		

Keterangan:

[ 1 ] = lebar tiap bagian (m)

[ 2 ] = tinggi tiap bagian (m)

[ 3 ] = panjang konstruksi

[ 4 ] = 1 digunakan untuk penampang persegi atau persegi panjang

= 0,5 digunakan untuk penampang segitiga

[ 5 ] = berat jenis beton bertulang = 2,4 ( $t/m^3$ )

= berat jenis air = 1,0 ( $t/m^3$ )

[ 6 ] = gaya vertikal (ton)

= [ 1 ] \* [ 2 ] \* [ 3 ] \* [ 4 ] \* [ 5 ] (untuk bangunan dan timbunan )

nilai (+) untuk arah gaya ke bawah

nilai (-) untuk arah gaya ke atas

[ 7 ] = gaya horizontal (ton)

= [ 6 ] \* kh , dengan kh = 0,15 (untuk berat bangunan)

$$= 7/12 * [ 1 ] * [ 2 ] * [ 3 ] * [ 4 ] * [ 5 ] * kh \text{ (untuk tekanan air dinamis)}$$

nilai (+) untuk arah gaya ke hilir

nilai (-) untuk arah gaya ke hulu

[ 8 ] = lengan momen gaya berat konstruksi (m)

[ 9 ] = momen (ton.m)

$$= [ 7 ] * [ 8 ]$$

Data Pilar IV :

1. Lebar (h) = 1,95 m
2. Tebal (b) = 2,50 m
3. Tinggi = 7,57 m

4. Mutu Bahan

Beton (fc') = 20,00 Mpa

Baja (fy) = 240,00 Mpa

5. Beban pada Pilar

a. Pu = 3407,45 kN

b. Mu = 2445,70 kN.m

a. Kontrol Kelangsingan

Pilar diasumsikan sebagai kolom tanpa pengaku, dibagian atas dan bawahnya jepit-jepit, maka  $k = 1,00$  (Tabel 2.7). Kelangsingan kolom dapat dihitung menggunakan persamaan (2-94) dan persamaan (2-95) sebagai berikut:

dimana:

$$A = (\text{Lebar} \times \text{tebal})$$

$$= (1,95 \times 2,50)$$

$$= 4,875 \text{ m}^2$$

$$I = \frac{1}{12} \cdot b \cdot h^3 = \frac{1}{12} \cdot 2,5 \cdot (1,95)^3$$

$$= 1,545 \text{ m}^4$$

$$r = \sqrt{\frac{I}{A}}$$

$$= \sqrt{\frac{1,545}{4,875}} = 0,563 \text{ m}$$

$$k \frac{\lambda_{n,k}}{r} < 22$$

$$1,0 \frac{7,57}{0,563} < 22$$

$$13,45 < 22 \text{ (Termasuk Kolom Pendek)}$$

b. Luas Penampang Pilar

$$\begin{aligned} \text{Agr} &= \text{Lebar} \times \text{tebal} \\ &= (1,95 \times 2,50) \\ &= 4,875 \text{m}^2 \\ &= 4,8 \cdot 10^6 \text{ mm}^2 \end{aligned}$$

c. Tulangan Kolom

Pada sumbu vertikal

$$\begin{aligned} \frac{P_u}{\phi \cdot \text{Agr} \cdot 0,85 \cdot f_c'} &= \frac{3407,45 \cdot 10^3}{0,65 \cdot 5,0 \cdot 10^6 \cdot 0,85 \cdot 20,00} \\ &= 0,063 < 0,10 \end{aligned}$$

$\phi$  ditingkatkan menjadi 0,80 maka:

$$\begin{aligned} \frac{P_u}{\phi \cdot \text{Agr} \cdot 0,85 \cdot f_c'} &= \frac{3407,45 \cdot 10^3}{0,80 \cdot 5,0 \cdot 10^6 \cdot 0,85 \cdot 20,00} \\ &= 0,051 < 0,10 \end{aligned}$$

$$\begin{aligned} e_t &= \frac{M_u}{P_u} \\ &= \frac{2445,70}{3407,45} \\ &= 0,718 \text{ m} \end{aligned}$$

$$e_t/h = 717,75/1950 = 0,37$$

Pada sumbu horizontal

$$\begin{aligned} \frac{P_u}{\phi \cdot \text{Agr} \cdot 0,85 \cdot f_c'} \left( \frac{e_t}{h} \right) &= 0,051 \cdot 0,37 \\ &= 0,01892 \end{aligned}$$

$$\text{Dengan } d'/h = 100/1950 = 0,05 \text{ diambil } d'/h = 0,1$$

Berdasarkan grafik pada Gambar 2.14, maka diperoleh  $r = 0,0008$  dan  $\beta = 0,80$

$$\begin{aligned} \rho &= \beta \cdot r \\ &= 0,80 \cdot 0,0008 \\ &= 0,00064 \end{aligned}$$

$$\begin{aligned} \text{Ag total} &= \rho \cdot \text{Agr} \\ &= 0,00064 \cdot 4,8 \cdot 10^6 \\ &= 3120,0 \text{ mm}^2 \\ &= 31,20 \text{ cm}^2 \end{aligned}$$

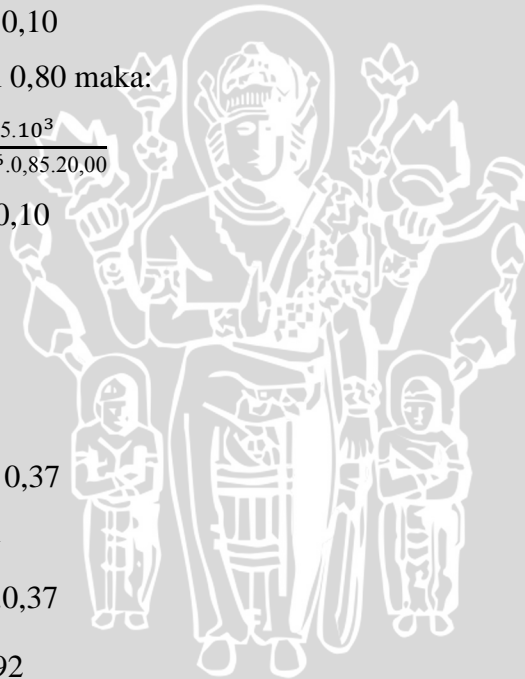



Dipakai: Tulangan utama 34 D 12- 250 mm<sup>2</sup> = 3827 mm<sup>2</sup> > 3120 mm<sup>2</sup>

d. Begel pada Kolom

Tebal selimut beton (ds) = 100 mm

$$\begin{aligned} d &= h - ds \\ &= 1950 - 100 \\ &= 1850 \text{ mm} \end{aligned}$$

1. Gaya geser perlu kolom ( $V_{u,k}$ )

$$\begin{aligned} V_{u,k} &= \frac{M_{u2} - M_{u1}}{\lambda_k} \\ &= \frac{2445,70}{7,57} \\ &= 323,08 \text{ kN} \\ &= 323077,82 \text{ N} \end{aligned}$$

2. Gaya geser yang ditahan oleh beton ( $V_c$ )

$$\begin{aligned} V_c &= \left(1 + \frac{N_{u,k}}{14 \cdot A_g}\right) \frac{\sqrt{f'_c}}{6} \cdot b \cdot d \\ &= \left(1 + \frac{3407,45 \cdot 10^3}{14 \cdot 2500 \cdot 1950}\right) \frac{\sqrt{20}}{6} \cdot 2500 \cdot 1850 \\ &= 3619380,095 \text{ N} \end{aligned}$$

3. Gaya geser yang ditahan oleh beton ( $V_s$ ) dan  $V_{s,maks}$

$$\begin{aligned} V_s &= \frac{V_u - \phi \cdot V_c}{\phi} \text{ dengan } \phi = 0,75 \\ &= \frac{323077,82 - 0,75 \cdot 3619380,095}{0,75} \\ &= -3188609,672 \text{ N} \end{aligned}$$

$$\begin{aligned} V_{s,max} &= \frac{2}{3} \cdot \sqrt{f'_c} \cdot b \cdot d \\ &= \frac{2}{3} \cdot \sqrt{20} \cdot 2500 \cdot 1850 \\ &= 13789085,9 \text{ N, syarat } V_s \leq V_{s,maks} \dots \text{ OK} \end{aligned}$$

4. Luas begel perlu ( $A_{v,u}$ ) untuk setiap panjang kolom  $S = 1000 \text{ mm}$ , dengan memilih yang terbesar dari nilai  $A_v$  berikut:

$$\begin{aligned} A_v &= \frac{V_s \cdot S}{f_y \cdot d} \\ &= \frac{-3188609,672 \cdot 1000}{240 \cdot 1850} \\ &= -7181,55 \text{ mm}^2 \end{aligned}$$

$$\begin{aligned} A_v &= \frac{b \cdot S}{3 \cdot f_y} \\ &= \frac{2500 \cdot 1000}{3 \cdot 240} = 3472,2 \text{ mm}^2 \end{aligned}$$

$$\begin{aligned}
 A_v &= \frac{75\sqrt{f_c'} \cdot b \cdot S}{1200 \cdot f_y} \\
 &= \frac{75\sqrt{20} \cdot 2500 \cdot 1000}{1200 \cdot 240} \\
 &= 2911,55 \text{ mm}^2
 \end{aligned}$$

Dipilih yang paling besar, jadi  $A_{v,u} = 3472,2 \text{ mm}^2$

Digunakan begel 2 kaki dengan  $d_p = 10 \text{ mm}$

#### 5. Jarak antar begel

$$\begin{aligned}
 s &= \frac{\frac{n}{4} \cdot \pi \cdot d_p^2 \cdot S}{A_{v,u}} \\
 &= \frac{\frac{2}{4} \cdot \pi \cdot 10^2 \cdot 1000}{3472,2} \\
 &= 45,24 \text{ mm}
 \end{aligned}$$

Kontrol jarak:

$$s \leq 16D = 192 \text{ mm}$$

$$s \leq 48 \cdot d_p = 480 \text{ mm}$$

$$s \leq d/2 = 925 \text{ mm}$$

$$s \leq 600 \text{ mm}$$

Dipakai nilai terkecil dan dibulatkan ke bawah, yaitu  $s = 45 \text{ mm} \leq 45,24 \text{ mm}$

(Dibaca: "Begel 2 kaki berdiameter polos 10 mm dan berjarak 45 mm")

#### 4.5.2.3.3. Pilar V

Perencanaan tulangan pada pilar ini menggunakan tulangan praktis yang berfungsi untuk menghindari keretakan pilar akibat susut beton. Pilar ini hanya menahan beban sendiri dikarenakan beban rumah operasional pintu, jembatan pelayanan dan jembatan kendaraan sudah dibebankan seluruhnya pada pilar I dan pilar II. Perhitungan gaya dan momen pilar dapat dilihat pada Tabel 4.60.

**Tabel 4.60. Gaya dan Momen Pilar V**

Notasi	Nilai								Gaya		Lengan Momen	Momen				
	Lebar (m)	Tinggi (m)	Panjang (m)	Ratio	$\gamma$ ( $t/m^3$ )				Pv (ton)	Ph (ton)	y (m)	My (ton.m)				
	[1]	[2]	[3]	[4]	[5]				[6]	[7]	[8]	[9]				
Wca	0,680	x	11,570	x	2,500	x	1,000	x	2,400	=	148,301	22,245	6,785	150,933		
Wcs	3,000	x	11,570	x	2,500	x	0,500	x	2,400	=	327,134	49,070	4,857	238,317		
Wcs	1,250	x	11,570	x	1,250	x	0,500	x	2,400	x	$\pi$	=	68,153	10,223	6,785	69,363
Total									$\Sigma V$	543,588		$\Sigma M_h$	458,613			
Sumber: Hasil Perhitungan									$\Sigma H$		81,538					
	Pu	=	1,200	x	$\Sigma V$				Mu	=	1,200	x	$\Sigma M_h$			
		=	1,200	x	543,588					=	1,200	x	458,613			
		=	652,305	ton						=	550,335	ton				

Keterangan:

- [ 1 ] = lebar tiap bagian (m)  
 [ 2 ] = tinggi tiap bagian (m)  
 [ 3 ] = panjang konstruksi  
 [ 4 ] = 1 digunakan untuk penampang persegi atau persegi panjang  
 = 0,5 digunakan untuk penampang segitiga  
 [ 5 ] = berat jenis beton bertulang =  $2,4 \text{ (t/m}^3\text{)}$   
 = berat jenis air =  $1,0 \text{ (t/m}^3\text{)}$   
 [ 6 ] = gaya vertikal (ton)  
 =  $[ 1 ] * [ 2 ] * [ 3 ] * [ 4 ] * [ 5 ]$  (untuk bangunan dan timbunan )  
 nilai (+) untuk arah gaya ke bawah  
 nilai (-) untuk arah gaya ke atas  
 [ 7 ] = gaya horizontal (ton)  
 =  $[ 6 ] * kh$ , dengan  $kh = 0,15$  (untuk berat bangunan)  
 =  $7/12 * [ 1 ] * [ 2 ] * [ 3 ] * [ 4 ] * [ 5 ] * kh$  (untuk tekanan air dinamis)  
 nilai (+) untuk arah gaya ke hilir  
 nilai (-) untuk arah gaya ke hulu  
 [ 8 ] = lengan momen gaya berat konstruksi (m)  
 [ 9 ] = momen (ton.m)  
 =  $[ 7 ] * [ 8 ]$

Data Pilar V :

1. Lebar (h) = 1,93 m
2. Tebal (b) = 2,50 m
3. Tinggi = 11,57 m
4. Mutu Bahan
  - Beton ( $f_c'$ ) = 20,00 Mpa
  - Baja ( $f_y$ ) = 240,00 Mpa
5. Beban pada Pilar
  - a. Pu = 6523,05 kN
  - b. Mu = 5503,35 kN.m

a. Kontrol Kelangsingan

Pilar diasumsikan sebagai kolom tanpa pengaku, dibagian atas dan bawahnya jepit-jepit, maka  $k = 1,00$  (Tabel 2.7). Kelangsingan kolom dapat dihitung menggunakan persamaan (2-94) dan persamaan (2-95) sebagai berikut:

dimana:

$$\begin{aligned} A &= (\text{Lebar} \times \text{tebal}) \\ &= (1,93 \times 2,50) \\ &= 4,825 \text{ m}^2 \end{aligned}$$

$$\begin{aligned} I &= \frac{1}{12} \cdot b \cdot h^3 = \frac{1}{12} \cdot 2,5 \cdot (1,93)^3 \\ &= 1,498 \text{ m}^4 \end{aligned}$$

$$\begin{aligned} r &= \sqrt{\frac{I}{A}} \\ &= \sqrt{\frac{1,498}{4,825}} = 0,557 \text{ m} \end{aligned}$$

$$k \frac{\lambda_{n,k}}{r} < 22$$

$$1,0 \frac{11,57}{0,557} < 22$$

$$20,77 < 22 \text{ (Termasuk Kolom Pendek)}$$

b. Luas Penampang Pilar

$$\begin{aligned} A_{gr} &= (\text{Lebar} \times \text{tebal}) + (1/2 \cdot \pi \cdot r^2) \\ &= (1,93 \times 2,50) + (1/2 \cdot \pi \cdot 1,25^2) \\ &= 4,154 \text{ m}^2 \\ &= 4,15 \cdot 10^6 \text{ mm}^2 \end{aligned}$$

c. Tulangan Kolom

Pada sumbu vertikal

$$\begin{aligned} \frac{P_u}{\phi \cdot A_{gr} \cdot 0,85 \cdot f_c'} &= \frac{6523,05 \cdot 10^3}{0,65 \cdot 4,1510^6 \cdot 0,85 \cdot 20,00} \\ &= 0,142 < 0,10 \end{aligned}$$

$$\begin{aligned} e_t &= \frac{M_u}{P_u} \\ &= \frac{5503,35}{6523,05} \end{aligned}$$

$$= 0,844 \text{ m}$$

$$e_t/h = 843,68/1930 = 0,44$$

Pada sumbu horizontal

$$\frac{P_u}{\phi \cdot A_{gr} \cdot 0,85 \cdot f_c'} \left( \frac{e_t}{h} \right) = 0,142 \cdot 0,44$$

$$= 0,06212$$

Dengan  $d'/h = 100/1930 = 0,05$  diambil  $d'/h = 0,1$

Berdasarkan grafik pada Gambar 2.14, maka diperoleh  $r = 0,003$  dan  $\beta = 0,80$

$$\rho = \beta \cdot r$$

$$= 0,80 \cdot 0,0030$$

$$= 0,0024$$

$$A_{g \text{ total}} = \rho \cdot A_{gr}$$

$$= 0,0024 \cdot 4 \cdot 10^6$$

$$= 9970,5 \text{ mm}^2$$

$$= 99,705 \text{ cm}^2$$

Dipakai: Tulangan utama 94 D 12- 90  $\text{mm}^2 = 10588 \text{ mm}^2 > 9970,5 \text{ mm}^2$

d. Begel pada Kolom

Tebal selimut beton ( $d_s$ ) = 100 mm

$$d = h - d_s$$

$$= 1930 - 100$$

$$= 1830 \text{ mm}$$

1. Gaya geser perlu kolom ( $V_{u,k}$ )

$$V_{u,k} = \frac{M_{u2} - M_{u1}}{\lambda_k}$$

$$= \frac{5503,35}{7,57}$$

$$= 727,00 \text{ kN}$$

$$= 726995,34 \text{ N}$$

2. Gaya geser yang ditahan oleh beton ( $V_c$ )

$$V_c = \left( 1 + \frac{N_{u,k}}{14 \cdot A_{gr}} \right) \frac{\sqrt{f_c'}}{6} \cdot b \cdot d$$

$$= \left( 1 + \frac{6523,05 \cdot 10^3}{14 \cdot 2500 \cdot 1930} \right) \frac{\sqrt{20}}{6} \cdot 2500 \cdot 1830$$

$$= 3739295,065 \text{ N}$$

3. Gaya geser yang ditahan oleh beton ( $V_s$ ) dan  $V_{s,\text{maks}}$

$$V_s = \frac{V_u - \phi \cdot V_c}{\phi} \text{ dengan } \phi = 0,75$$

$$= \frac{726995,34 - 0,75 \cdot 3739295,065}{0,75}$$

$$= -2769967,942 \text{ N}$$

$$V_{s,\max} = \frac{2}{3} \cdot \sqrt{f_c'} \cdot b \cdot d$$

$$= \frac{2}{3} \cdot \sqrt{20} \cdot 2500 \cdot 1830$$

$$= 13640014,66 \text{ N, syarat } V_s \leq V_{s,\max} \dots \text{ OK}$$

4. Luas begel perlu ( $A_{v,u}$ ) untuk setiap panjang kolom  $S = 1000 \text{ mm}$ , dengan memilih yang terbesar dari nilai  $A_v$  berikut:

$$A_v = \frac{V_s \cdot S}{f_y \cdot d}$$

$$= \frac{-2769967,942 \cdot 1000}{240 \cdot 1830}$$

$$= -6306,85 \text{ mm}^2$$

$$A_v = \frac{b \cdot S}{3 \cdot f_y}$$

$$= \frac{2500 \cdot 1000}{3 \cdot 240} = 3472,2 \text{ mm}^2$$

$$A_v = \frac{75 \sqrt{f_c'} \cdot b \cdot S}{1200 \cdot f_y}$$

$$= \frac{75 \sqrt{20} \cdot 2500 \cdot 1000}{1200 \cdot 240}$$

$$= 2911,55 \text{ mm}^2$$

Dipilih yang paling besar, jadi  $A_{v,u} = 3472,2 \text{ mm}^2$

Digunakan begel 2 kaki dengan  $d_p = 10 \text{ mm}$

5. Jarak antar begel

$$s = \frac{\frac{n}{4} \cdot \pi \cdot d_p^2 \cdot S}{A_{v,u}}$$

$$= \frac{\frac{2}{4} \cdot \pi \cdot 10^2 \cdot 1000}{3472,2}$$

$$= 45,24 \text{ mm}$$

Kontrol jarak:

$$s \leq 16D = 192 \text{ mm}$$

$$s \leq 48 \cdot d_p = 480 \text{ mm}$$

$$s \leq d/2 = 915 \text{ mm}$$

$$s \leq 600 \text{ mm}$$

Dipakai nilai terkecil dan dibulatkan ke bawah, yaitu  $s = 45 \text{ mm} \leq 45,24 \text{ mm}$

(Dibaca: "Begel 2 kaki berdiameter polos 10 mm dan berjarak 45 mm")

Gambar penulangan pada pilar I, II, III, IV dan V dapat dilihat pada Gambar 4.68. berikut ini:

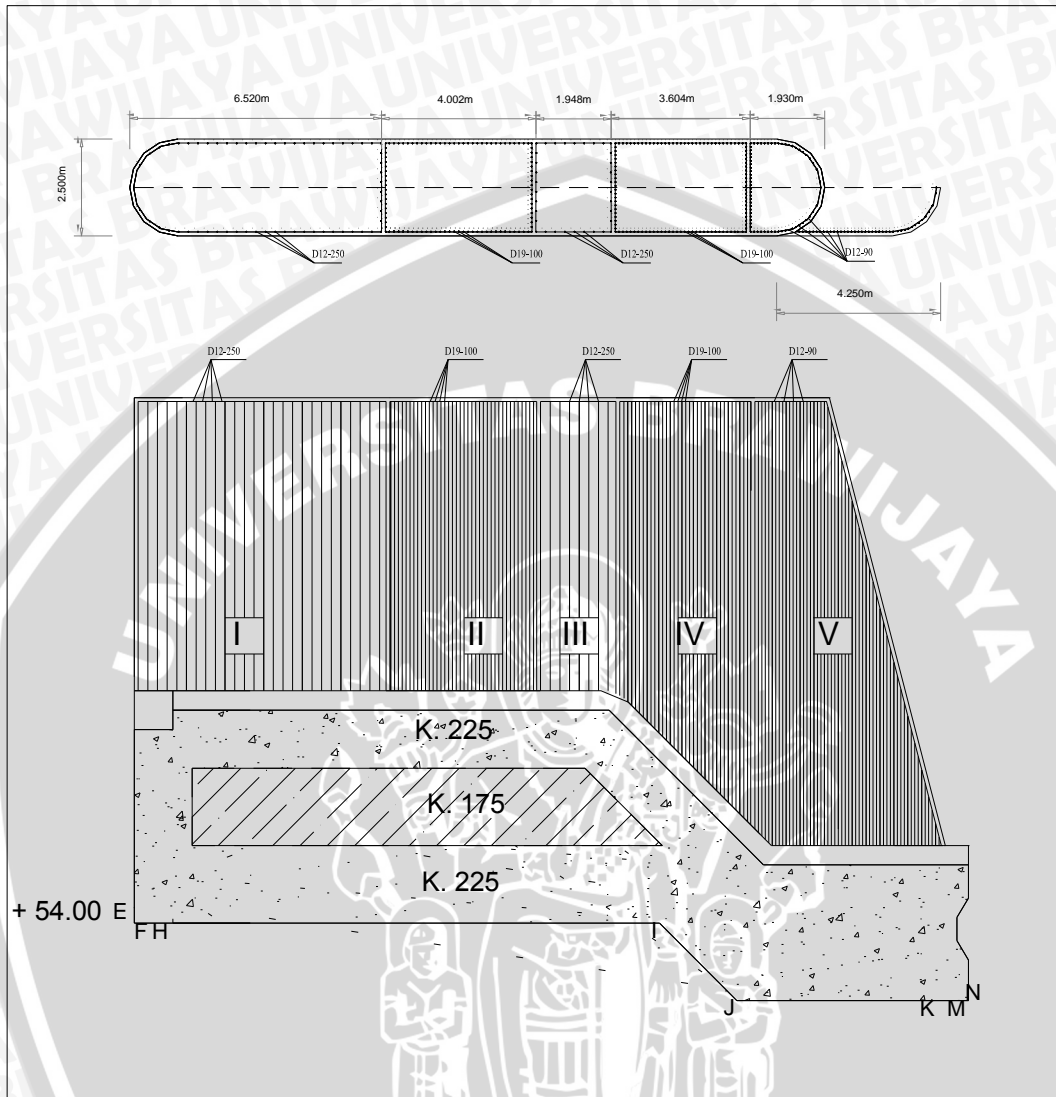

**Gambar 4.68. Penulangan Pada Pilar I, II, III, IV dan V**

#### 4.5.2.4. Pelimpah Penguras

Perencanaan pembetonan dan penulangan pada pelimpah ini menanggung beban air dan beban pintu yang diatas yaitu ditinjau seluas  $1 \text{ m}^2$ . Berikut ini perhitungan dari pembetonan dan penulangan pelimpah:

1. Data pelimpah:

- a. Elevasi muka air banjir = El. 66.07 m
- b. Elevasi puncak penguras = El. 60.00 m
- c. Beban pintu (per 1 meter) = 12,191 ton/m
- d. Tinggi muka air normal (H) = 6,070 m

- e. Lapisan beton  
 Tebal bruto (h) = 1000 mm  
 Tebal efektif (d) = 900 mm
- f. Lebar tinjauan (b) = 1000 mm
- g. Mutu beton ( $f_c'$ ) = 20,00 Mpa
- h. Mutu baja ( $f_y$ ) = 240,00 Mpa

## 2. Beban pada Beton

- a. Tekanan air per meter lebar

$$\begin{aligned} q &= H \cdot \gamma / m \\ &= 6,070 \cdot 1,00 / m \\ &= 6,070 \text{ ton/m} \end{aligned}$$

$$\begin{aligned} q \text{ total} &= q_{\text{air}} + q_{\text{pintu}} \\ &= 6,070 + 12,191 \\ &= 18,26 \text{ ton/m}^2 \end{aligned}$$

- b. Momen lentur

$$\begin{aligned} M &= \frac{1}{8} \cdot q \cdot l^2 \\ &= \frac{1}{8} \cdot 18,26 \cdot 1,00^2 \\ &= 1,848 \text{ ton.m} \\ &= 18,49 \text{ kNm} \end{aligned}$$

- c. Momen ultimate

$$\begin{aligned} M_u &= 1,2 \cdot M \\ &= 1,2 \cdot 18,49 \\ &= 22,1871 \text{ kNm} \end{aligned}$$

- d. Perhitungan tulangan beton

$$\begin{aligned} K &= \frac{M_u}{\sigma_b \cdot b \cdot d^2} \\ &= \frac{22,187 \cdot 10^6}{0,8 \cdot 1000 \cdot 900^2} \\ &= 0,034 \text{ Mpa} \end{aligned}$$

$$\begin{aligned} K_{\text{max}} &= \frac{382,5 \cdot \beta_1 \cdot f_c' \cdot (600 + f_y - 225 \cdot \beta_1)}{(600 + f_y)^2} \\ &= \frac{382,5 \cdot 0,85 \cdot 20 \cdot (600 + 240 - 225 \cdot 0,85)}{(600 + 240)^2} \\ &= 5,979 \text{ Mpa} \end{aligned}$$





$$a = \left(1 - \sqrt{1 - \frac{2K}{0,85 \cdot f_c'}}\right) d$$

$$= \left(1 - \sqrt{1 - \frac{2,0,034}{0,85 \cdot 20}}\right) 900$$

$$= 1,81 \text{ mm}$$

c. Tulangan utama (tarik)

$$A_s = \frac{0,85 \cdot f_c' \cdot a \cdot b}{f_y}$$

$$= \frac{0,85 \cdot 20 \cdot 1,81 \cdot 1000}{240}$$

$$= 128,53 \text{ mm}^2$$

Dipakai tulangan :  $\phi 10 - 450 \text{ mm} = 174,53 \text{ mm}^2 > 128,53 \text{ mm}^2$

d. Tulangan pembagi (tarik)

$$A_{s,b} = 20\% \cdot A_{s,u}$$

$$= 20\% \cdot 128,53 \text{ mm}^2$$

$$= 25,71 \text{ mm}^2$$

Dipakai tulangan :  $\phi 6 - 450 \text{ mm} = 62,83 \text{ mm}^2 > 25,71 \text{ mm}^2$

#### 4.5.2.5. Pelat Pondasi Bangunan Penguras (*Sluice Gate*)

Pelat pondasi pada bangunan penguras ini berguna untuk menahan beban secara keseluruhan yang berada di atasnya. Baik itu berupa beban pilar, pintu maupun beban air. Momen yang ada dihitung dengan mengalikan eksentrisitas dengan beban vertikal yang terjadi. (lihat Tabel 4.13. Analisis Stabilitas Bangunan Penguras pada Kondisi Normal (Gempa)). Berikut ini contoh perhitungannya:

Data:

Gaya vertikal rencana ultimit ( $P_u$ )	=	25229,27 kN
Eksentrisitas ( $e$ )	=	0,83
Momen rencana ultimit ( $M_u$ )	=	21059,17 kNm
Mutu beton, Kuat tekan beton ( $f_c'$ )	=	20,0 MPa
Mutu Baja, Tegangan leleh baja ( $f_y$ )	=	240 MPa
Tebal beton ( $h$ )	=	2000 mm
Selimut beton ( $p$ )	=	100 mm
Tebal efektif $d = h - p$	=	1900 mm
Lebar yang ditinjau ( $b$ )	=	7500 mm

Perhitungan:

$$K = \frac{M_u}{\phi_b \cdot d^2}$$

$$= \frac{20663,11 \cdot 10^6}{0,8 \cdot 7500 \cdot 1900^2}$$

$$= 0,972 \text{ Mpa}$$

$$K_{max} = \frac{382,5 \beta_1 \cdot f_c' \cdot (600 + f_y - 225 \beta_1)}{(600 + f_y)^2}$$

$$= \frac{382,5 \cdot 0,85 \cdot 20 \cdot (600 + 240 - 225 \cdot 0,85)}{(600 + 240)^2}$$

$$= 5,979 \text{ Mpa}$$

$$a = \left( 1 - \sqrt{1 - \frac{2K}{0,85 \cdot f_c'}} \right) d$$

$$= \left( 1 - \sqrt{1 - \frac{2 \cdot 0,972}{0,85 \cdot 20}} \right) 1900$$

$$= 111,96 \text{ mm}$$

a. Tulangan utama (tarik)

$$A_s = \frac{0,85 \cdot f_c' \cdot a \cdot b}{f_y}$$

$$= \frac{0,85 \cdot 20 \cdot 111,96 \cdot 7500}{240}$$

$$= 59480,52 \text{ mm}^2$$

Dipakai tulangan : D25 – 50 mm = 73631,08 mm<sup>2</sup> > 59480,52 mm<sup>2</sup>

b. Tulangan pembagi (tarik)

$$A_{s,b} = 20\% \cdot A_s$$

$$= 20\% \cdot 59480,52 \text{ mm}^2$$

$$= 11896,10 \text{ mm}^2$$

Dipakai tulangan : D16 – 125 mm = 12063,72 mm<sup>2</sup> > 11896,10 mm<sup>2</sup>

Dipakai tulangan : D10 – 50 mm = 7539,82 mm<sup>2</sup> > 5948,05 mm<sup>2</sup>

Gambar detail pada pelimpah dan plat pondasi bangunan penguras (*sluice gate*) dapat dilihat pada Gambar 4.69. berikut ini:

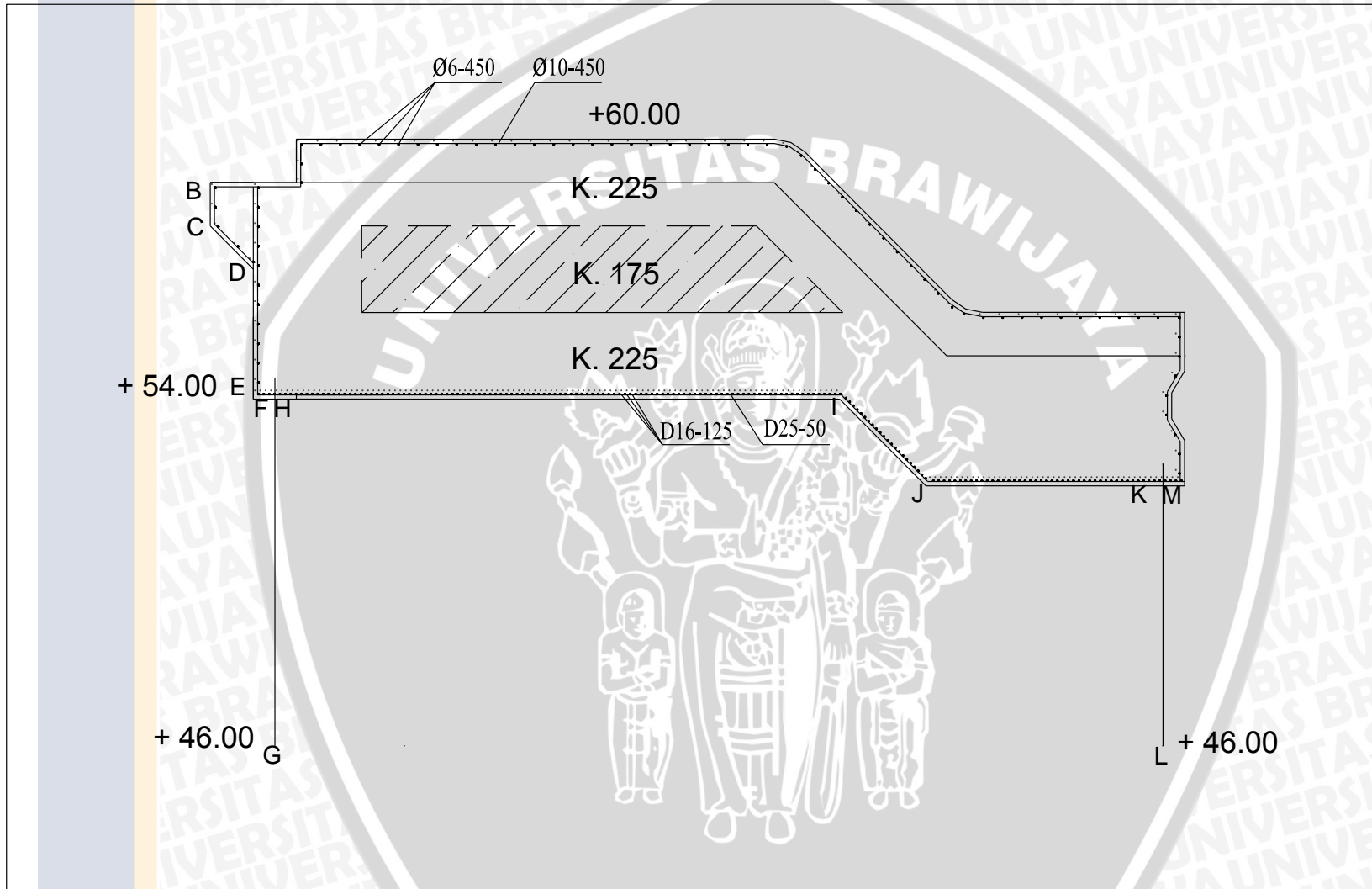

Gambar 4.69. Penulangan Pada Pelimpah dan Pelat Pondasi Bangunan Penguras (*Sluice Gate*)

### 4.5.3. Dinding Penahan Bagian Hulu

Untuk menganalisis pembetonan dan penulangan pada dinding penahan, perlu memperhatikan bagian-bagian kritis yang nantinya berpengaruh terhadap kerusakan pada dinding penahan. Perhitungan bending momen yang terjadi pada dinding penahan dianalisis dengan 4 potongan yaitu potongan A-A, potongan B-B, potongan C-C dan potongan D-D. Contoh perhitungan penulangan menggunakan kondisi yang paling kritis yaitu kondisi banjir pada keadaan gempa.

Data:

Momen rencana ultimate, $M_u$	= 231,49 kNm
Mutu beton, $f_c'$	= 20,00 Mpa
Mutu baja, $f_y$	= 240 Mpa
Tebal beton, $h$	= 1250 mm
Selimit beton, $p$	= 100 mm
Lebar yang ditinjau, $b$	= 1000 mm
Faktor bentuk distribusi tegangan, $\beta$	= 0,85

Perhitungan Penulangan:

$$\begin{aligned} \text{Tinggi efektif (d)} &= h - p \\ &= 1250 - 100 \\ &= 1150 \text{ mm} \end{aligned}$$

$$\begin{aligned} \text{Momen tumpuan (K)} &= \frac{M_u}{\phi_b \cdot d^2} \\ &= \frac{231,49 \cdot 10^6}{0,85 \cdot 1000 \cdot 1150^2} \\ &= 0,219 \text{ Mpa} \end{aligned}$$

$$\begin{aligned} K_{\max} &= \frac{382,5 \cdot \beta_1 \cdot f_c' \cdot (600 + f_y - 225 \cdot \beta_1)}{(600 + f_y)^2} \\ &= \frac{382,5 \cdot 0,85 \cdot 20 \cdot (600 + 240 - 225 \cdot 0,85)}{(600 + 240)^2} \\ &= 5,979 \text{ Mpa} \end{aligned}$$

$$\begin{aligned} \text{Tinggi blok tegangan beton (a)} &= \left( 1 - \sqrt{1 - \frac{2K}{0,85 \cdot f_c'}} \right) d \\ &= \left( 1 - \sqrt{1 - \frac{2 \cdot 0,219}{0,85 \cdot 20}} \right) 1150 \\ &= 14,90 \text{ mm} \end{aligned}$$

$$\begin{aligned}
 \text{a. Luas tulangan utama (tarik), } A_{s,u} &= \frac{0,85 \cdot f_c' \cdot a \cdot b}{f_y} \\
 &= \frac{0,85 \cdot 20 \cdot 14,90 \cdot 1000}{240} \\
 &= 1055,25 \text{ mm}^2
 \end{aligned}$$

$$\text{Dipakai tulangan : D22 - 200 mm} = 1900,66 \text{ mm}^2 > 1055,25 \text{ mm}^2$$

b. Tulangan pembagi (tarik)

$$\begin{aligned}
 A_{s,b} &= 20\% \cdot A_{s,u} \\
 &= 20\% \cdot 1055,25 \text{ mm}^2 \\
 &= 211,05 \text{ mm}^2
 \end{aligned}$$

$$\text{Dipakai tulangan : D16 - 450 mm} = 446,80 \text{ mm}^2 > 211,05 \text{ mm}^2$$

c. Tulangan utama (tekan)

$$\begin{aligned}
 A_s &= 50\% \cdot A_{s,u} \\
 &= 50\% \cdot 1055,25 \\
 &= 527,63 \text{ mm}^2
 \end{aligned}$$

$$\text{Dipakai tulangan : D16 - 300 mm} = 670,21 \text{ mm}^2 > 527,63 \text{ mm}^2$$

d. Tulangan pembagi (tekan)

$$\begin{aligned}
 A_{s,b} &= 20\% \cdot A_s \\
 &= 20\% \cdot 527,63 \\
 &= 105,53 \text{ mm}^2
 \end{aligned}$$

$$\text{Dipakai tulangan : D8 - 50 mm} = 111,70 \text{ mm}^2 > 105,53 \text{ mm}^2$$

Perhitungan bending momen dinding penahan hulu kondisi muka air banjir (gempa) dapat dilihat pada Tabel 4.61 sampai Tabel 4.64 dan diagram gaya dan momen yang bekerja pada dinding penahan dapat dilihat pada Gambar 4.70 sampai Gambar 4.73. Gambar detail penulangan pada dinding penahan bagian hulu dapat dilihat pada Gambar 4.74.

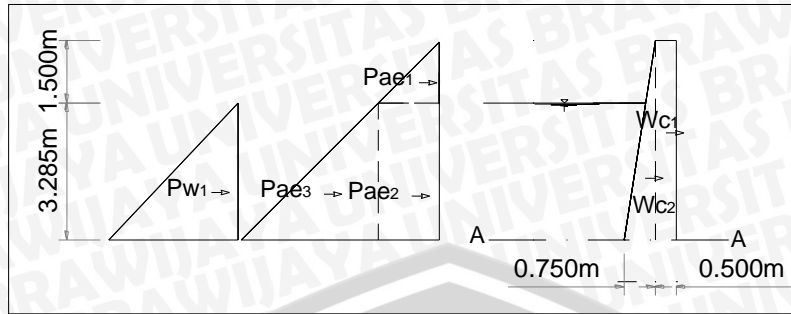

Gambar 4.70. Bending Momen Dinding Penahan Hulu Potongan A-A Kondisi Muka Air Banjir Gempa

Tabel 4.61. Bending Momen Dinding Penahan Hulu Potongan A-A Kondisi Muka Air Banjir Gempa

No.	Notasi	Tekanan / Luas penampang								Gaya (ton)	Lengan Y (m)	Momen (ton.m)					
1	PaeH <sub>1</sub>	1,200	x	0,500	x	Kae	x	h <sub>1</sub>	x	h <sub>1</sub>	x	γ	1,172	3,785	4,436		
		1,200	x	0,500	x	0,482	x	1,500	x	1,500	x	1,800					
2	PaeH <sub>2</sub>	1,200	x	Kae	x	γ <sub>sub</sub>	x	h <sub>1</sub>	x	h <sub>2</sub>			2,785	1,643	4,574		
		1,200	x	0,482	x	0,976	x	1,500	x	3,285							
3	PaeH <sub>3</sub>	1,200	x	0,500	x	Kae	x	h <sub>2</sub>	x	h <sub>2</sub>	x	γ <sub>sub</sub>	3,050	1,095	3,339		
		1,200	x	0,500	x	0,482	x	3,285	x	3,285	x	0,976					
7	Wc <sub>1</sub>	1,200	x	Lebar	x	Tinggi	x	Panjang	x	Rasio	x	γ	x	Kh			
		1,200	x	0,500	x	4,785	x	1,000	x	1,000	x	2,400	x	0,150	1,034	2,393	2,473
8	Wc <sub>2</sub>	1,200	x	0,750	x	4,785	x	1,000	x	0,500	x	2,400	x	0,150	0,775	1,595	1,236
9	Pw <sub>1</sub>	1,200	x	0,500	x	h <sub>2</sub>	x	h <sub>2</sub>	x	γ <sub>w</sub>			6,475	1,095	7,090		
		1,200	x	0,500	x	3,285	x	3,285	x	1,000							
Total										15,290		23,149					
Momen rencana ultimit, Mu		= 231,49 kNm										<b>Tulangan Tarik</b>					
Gaya vertikal rencana ultimit, Pu		= 152,90 kN										<b>Tulangan Utama :</b>					
Mutu beton, f <sub>c</sub> '		= 20,0 MPa										Luas tulangan, = 1055,25 mm <sup>2</sup>					
Mutu Baja, f <sub>y</sub>		= 240 MPa										Diameter tulangan, d = 22,00 mm					
Tebal beton, h		= 1250 mm										Jarak tulangan yang diperlukan, = 360,23 mm					
Selimut beton, p		= 100 mm										Jarak tulangan yang digunakan, = 200,00 mm					
Tebal efektif, d = h - p		= 1150 mm										Luas tulangan yang digunakan, = 1900,66 mm <sup>2</sup>					
Lebar yang ditinjau, b		= 1000 mm										D 22 - 200					
Modulus elastis baja, E <sub>s</sub>		= 2.E+05										<b>Tulangan Bagi :</b>					
Faktor bentuk distribusi tegangan betu, β <sub>1</sub>		= 0,85										Luas tulangan, A <sub>s,b</sub> = 20 % . A <sub>s,u</sub> = 211,05 mm <sup>2</sup>					
Faktor reduksi kekuatan lentur, φ		= 0,80										Diameter tulangan, d = 16,00 mm					
Momen tumpuan, K = $\frac{Mu}{\phi . bd^2}$		= 0,219 MPa										Jarak tulangan yang diperlukan, = 952,67 mm					
Kmaks = $\frac{382,5 . \beta_1 . f_c' . (600 + f_y - 225 . \beta_1)}{(600 + f_y)^2}$		= 5,98 MPa										Jarak tulangan yang digunakan, = 450,00 mm					
a = $(1 - (1 - \frac{2K}{0,85 . f_c'})^{0,5} . d)$		= 14,90 mm										Luas tulangan yang digunakan, = 446,80 mm <sup>2</sup>					
												D 16 - 450					
												<b>Tulangan Tekan</b>					
												<b>Tulangan Utama :</b>					
												Luas tulangan, A <sub>s,u</sub> = 50 % . A <sub>s,u</sub> tarik = 527,63 mm <sup>2</sup>					
												Diameter tulangan, d = 16,00 mm					
												Jarak tulangan yang diperlukan, = 381,07 mm					
												Jarak tulangan yang digunakan, = 300,00 mm					
												Luas tulangan yang digunakan, = 670,21 mm <sup>2</sup>					
												D 16 - 300					
												<b>Tulangan Bagi :</b>					
												Luas tulangan, A <sub>s,b</sub> = 20 % . A <sub>s,u</sub> = 105,53 mm <sup>2</sup>					
												Diameter tulangan, d = 8,00 mm					
												Jarak tulangan yang diperlukan, = 476,34 mm					
												Jarak tulangan yang digunakan, = 450,00 mm					
												Luas tulangan yang digunakan, = 111,70 mm <sup>2</sup>					
												D 8 - 450					

Sumber: Hasil Perhitungan

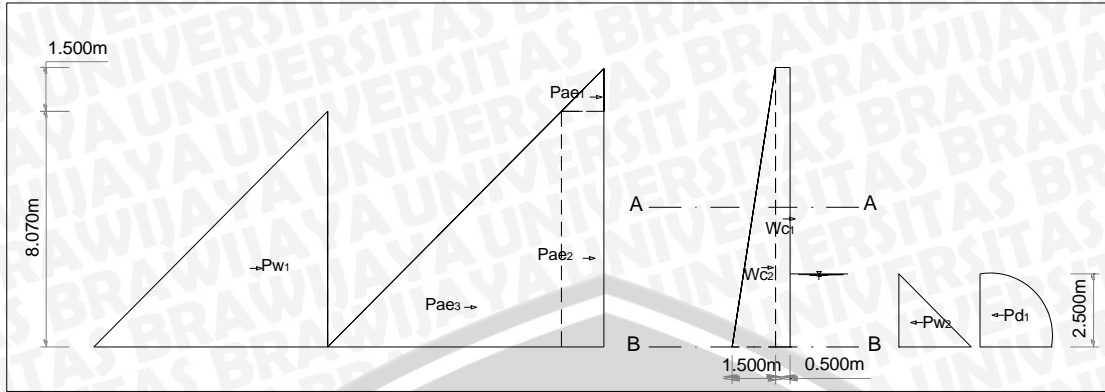

Gambar 4.71. Bending Momen Dinding Penahan Hulu Potongan B-B Kondisi Muka Air Banjir Gempa

Tabel 4.62. Bending Momen Dinding Penahan Hulu Potongan B-B Kondisi Muka Air Banjir Gempa

No.	Notasi	Tekanan / Luas penampang										Gaya (ton)	Lengan (m)	Momen (ton.m)				
1	PaeH <sub>1</sub>	1,200	x	0,500	x	Kae	x	h <sub>1</sub>	x	h <sub>1</sub>	x	γ	1,172	8,570	10,045			
		1,200	x	0,500	x	0,482	x	1,500	x	1,500	x	###						
2	PaeH <sub>2</sub>	1,200	x	Kae	x	h <sub>1</sub>	x	h <sub>2</sub>	x	γ	12,612	4,035	50,889					
		1,200	x	0,482	x	1,500	x	8,070	x	1,800								
3	PaeH <sub>3</sub>	1,200	x	0,500	x	Kae	x	h <sub>2</sub>	x	h <sub>2</sub>	x	γsub	18,404	2,690	49,507			
		1,200	x	0,500	x	0,482	x	8,070	x	8,070	x	###						
4	Pw <sub>1</sub>	1,200	x	0,500	x	h <sub>2</sub>	x	h <sub>2</sub>	x	γw	39,075	2,690	105,112					
		1,200	x	0,500	x	8,070	x	8,070	x	1,000								
5	Pw <sub>2</sub>	1,200	x	0,500	x	h <sub>3</sub>	x	h <sub>3</sub>	x	γw	-3,750	0,833	-3,125					
		1,200	x	0,500	x	2,500	x	2,500	x	1,000								
6	Pd <sub>1</sub>	1,200	x	(7/12)	x	h <sub>3</sub>	x	h <sub>3</sub>	x	γw	x	kh	-0,656	0,833	-0,547			
		1,200	x	0,583	x	2,500	x	2,500	x	1,000	x	###						
7	Wc <sub>1</sub>	1,200	x	Lebar	x	Tinggi	x	Panjang	x	Rasio	x	fbetor	x	kh	0,150	2,067	4,785	9,891
		1,200	x	0,500	x	9,570	x	1,000	x	1,000	x	###	x					
		1,200	x	1,500	x	9,570	x	1,000	x	0,500	x	###	x					
Total											72,024		231,663					
Momen rencana ultimit, Mu =		2316,63 kNm																
Gaya vertikal rencana ultimit, Pu =		720,24 kN																
Mutu beton, Kuat tekan beton, fc' =		20,0 MPa																
Mutu Baja, Tegangan leleh baja, fy =		240,0 MPa																
Tebal beton, h =		2000 mm																
Selimut beton, p =		100 mm																
Tebal efektif, d = h - p =		1900 mm																
Lebar yang ditinjau, b =		1000 mm																
Modulus elastis baja, Es =		2.E+05																
Faktor bentuk distribusi tegangan beton, β =		0,85																
Faktor reduksi kekuatan lentur, φ =		0,80																
Momen tumpuan, K = $\frac{Mu}{\phi . bd^2}$		0,802 MPa																
Knaks = $\frac{382,5 . \beta_1 . fc' . (600 + fy - 225 . \beta_1)}{(600 + fy)^2}$		5,98 MPa																
a = $(1 - (1 - \frac{2K}{0,85 . fc'})^{0,5}) . d$		91,87 mm																
											<b>Tulangan Tarik</b>							
											<b>Tulangan Utama :</b>							
											Luas tulangan,	=	6507,74 mm <sup>2</sup>					
											Diameter tulangan,	d =	22 mm					
											Jarak tulangan yang diperlukan,	=	58,41 mm					
											Jarak tulangan yang digunakan,	=	100,00 mm					
											Luas tulangan yang digunakan,	=	7602,65 mm <sup>2</sup>					
											2D	22	- 200					
											<b>Tulangan Bagi :</b>							
											Luas tulangan, As,b = 20 % . As,u	=	1301,55 mm <sup>2</sup>					
											Diameter tulangan,	d =	16 mm					
											Jarak tulangan yang diperlukan,	=	154,48 mm					
											Jarak tulangan yang digunakan,	=	150,00 mm					
											Luas tulangan yang digunakan,	=	1340,41 mm <sup>2</sup>					
											D	16	- 150					
											<b>Tulangan Tekan</b>							
											<b>Tulangan Utama :</b>							
											Luas tulangan, As,u = 50% . As,u tarik	=	3253,87 mm <sup>2</sup>					
											Diameter tulangan,	d =	16 mm					
											Jarak tulangan yang diperlukan,	=	61,79 mm					
											Jarak tulangan yang digunakan,	=	50,00 mm					
											Luas tulangan yang digunakan,	=	4021,24 mm <sup>2</sup>					
											D	16	- 50					
											<b>Tulangan Bagi :</b>							
											Luas tulangan, As,b = 20 % . As,u	=	650,77 mm <sup>2</sup>					
											Diameter tulangan,	d =	8 mm					
											Jarak tulangan yang diperlukan,	=	77,24 mm					
											Jarak tulangan yang digunakan,	=	50,00 mm					
											Luas tulangan yang digunakan,	=	1005,31 mm <sup>2</sup>					
											D	8	- 50					

Sumber: Hasil Perhitungan

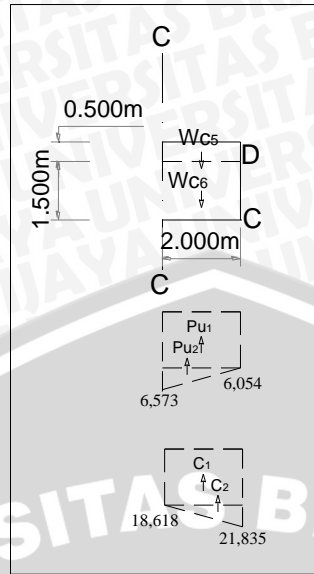

**Gambar 4.72. Bending Momen Dinding Penahan Hulu Potongan C-C Kondisi Muka Air Banjir Gempa**

**Tabel 4.63. Bending Momen Dinding Penahan Hulu Potongan C-C Kondisi Muka Air Banjir Gempa**

No.	Notasi	Tekanan / Luas penampang								Gaya (ton)	Lengan X (m)	Momen (ton.m)											
1	Wc <sub>5</sub> Wc <sub>6</sub>	1,200	x	Lebar	x	Tinggi	x	Panjang	x	rasio	x	γ	2,880 8,640	0,667 1,000	1,920 8,640								
		1,200	x	2,000	x	0,500	x	1,000	x	1,000	x	2,400											
		1,200	x	2,000	x	1,500	x	1,000	x	1,000	x	2,400											
2	Pu <sub>1</sub> Pu <sub>2</sub>	1,200	x	Lebar	x	Tinggi	x	Panjang	x	rasio	x	γ	-14,531 -0,622	1,000 1,333	-14,531 -0,829								
		1,200	x	2,000	x	6,054	x	1,000	x	1,000	x	1,000											
		1,200	x	2,000	x	0,518	x	1,000	x	0,500	x	1,000											
3	C <sub>1</sub> C <sub>2</sub>	1,200	x	Lebar	x	Tinggi	x	Panjang	x	rasio			-44,683 -3,861	1,000 1,333	-44,683 -5,147								
		1,200	x	2,000	x	18,618	x	1,000	x	1,000													
		1,200	x	2,000	x	3,217	x	1,000	x	0,500													
<b>Total</b>										<b>-52,176</b>		<b>-54,630</b>											
Momen rencana ultimit, Mu = 546,30 kNm		Gaya vertikal rencana ultimit, Pu = 521,76 kN		Mutu beton, Kuat tekan beton fc' = 20,0 MPa		Mutu Baja, Tegangan leleh baja fy = 240,0 MPa		Tebal beton, h = 2000 mm		Selimut beton, p = 100 mm		Tebal efektif, d = h - p = 1900 mm		Lebar yang ditinjau, b = 1000 mm		Modulus elastis baja, Es = 2,E+05		Faktor bentuk distribusi tegangan beton, β1 = 0,85		Faktor reduksi kekuatan lentur, φ = 0,80		Momen tumpuan, K = $\frac{Mu}{\phi \cdot bd^2} = 0,19$ MPa	
Kmaks = $\frac{382,5 \cdot \beta1 \cdot fc' \cdot (600 + fy - 225 \cdot \beta1)}{(600 + fy)^2} = 5,98$ MPa		a = $(1 - (1 - \frac{2K}{0,85 \cdot fc'})^{0,5}) \cdot d = 21,26$ mm		<b>Tulangan Tarik</b>		<b>Tulangan Utama :</b>		Luas tulangan, = 1505,97 mm <sup>2</sup>		Diameter tulangan, d = 22 mm		Jarak tulangan yang diperlukan, = 252,42 mm		Jarak tulangan yang digunakan, = 250,00 mm		Luas tulangan yang digunakan, = 1520,53 mm <sup>2</sup>		D 22 = 250					
																		<b>Tulangan Bagi :</b>					
																		Luas tulangan, As,b = 20 % . As,u = 301,19 mm <sup>2</sup>					
																		Diameter tulangan, d = 16 mm					
																		Jarak tulangan yang diperlukan, = 667,55 mm					
																		Jarak tulangan yang digunakan, = 450,00 mm					
																		Luas tulangan yang digunakan, = 446,80 mm <sup>2</sup>					
																		D 16 = 450					
																		<b>Tulangan Tekan</b>					
																		<b>Tulangan Utama :</b>					
																		Luas tulangan, As,u = 50% . As,u tarik = 752,99 mm <sup>2</sup>					
																		Diameter tulangan, d = 16 mm					
																		Jarak tulangan yang diperlukan, = 267,02 mm					
																		Jarak tulangan yang digunakan, = 150,00 mm					
																		Luas tulangan yang digunakan, = 1340,41 mm <sup>2</sup>					
																		D 16 = 150					
																		<b>Tulangan Bagi :</b>					
																		Luas tulangan, As,b = 20 % . As,u = 150,60 mm <sup>2</sup>					
																		Diameter tulangan, d = 8 mm					
																		Jarak tulangan yang diperlukan, = 333,77 mm					
																		Jarak tulangan yang digunakan, = 300,00 mm					
																		Luas tulangan yang digunakan, = 167,55 mm <sup>2</sup>					
																		D 8 = 300					

Sumber: Hasil Perhitungan



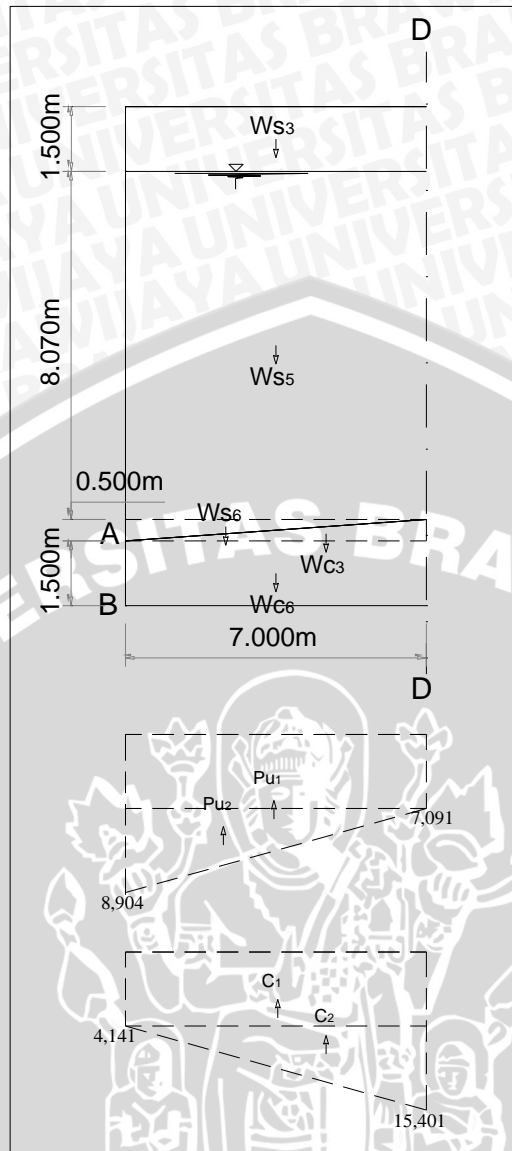

**Gambar 4.73. Bending Momen Dinding Penahan Hulu Potongan D-D Kondisi Muka Air Banjir Gempa**

**Tabel 4.64. Bending Momen Dinding Penahan Hulu Potongan D-D Kondisi Muka Air Banjir Gempa**

No.	Notasi	Tekanan / Luas penampang									Gaya ( ton )	Lengan X ( m )	Momen ( ton.m )		
1	Wc <sub>3</sub> Wc <sub>6</sub>	1,200	x	Lebar	x	Tinggi	x	Panjang	x	rasio	x	y	5,040	2,333	11,760
		1,200	x	7,000	x	0,500	x	1,000	x	0,500	x	2,400			
2	Ws <sub>3</sub> Ws <sub>5</sub> Ws <sub>6</sub>	1,200	x	Lebar	x	Tinggi	x	Panjang	x	rasio	x	y	11,340	3,500	39,690
		1,200	x	7,000	x	1,500	x	1,000	x	0,500	x	1,800			
		1,200	x	7,000	x	8,070	x	1,000	x	1,000	x	1,976			
		1,200	x	7,000	x	0,500	x	1,000	x	0,500	x	1,976			
3	Pu <sub>1</sub> Pu <sub>2</sub>	1,200	x	Lebar	x	Tinggi	x	Panjang	x	rasio		-59,562	3,500	-208,467	
		1,200	x	7,000	x	7,091	x	1,000	x	1,000					
4	C <sub>1</sub> C <sub>2</sub>	1,200	x	Lebar	x	Tinggi	x	Panjang	x	rasio		-34,783	3,500	-121,742	
		1,200	x	7,000	x	4,141	x	1,000	x	1,000					
<b>Total</b>											<b>35,498</b>		<b>114,318</b>		
Momen rencana ultimit,		Mu	=	1143,18	kNm	<b>Tulangan Tarik</b>									
Gaya vertikal rencana ultimit,		Pu	=	354,98	kN	<b>Tulangan Utama :</b>									
Mutu beton,	Kuat tekan beton	fc'	=	20,0	MPa	Luas tulangan,							3171,07	mm <sup>2</sup>	
Mutu Baja,	Tegangan leleh baja	fy	=	240	MPa	Diameter tulangan,		d	=	22	mm				
Tebal beton,		h	=	2000	mm	Jarak tulangan yang diperlukan,			=	119,88	mm				
Selimut beton,		p	=	100	mm	Jarak tulangan yang digunakan,			=	100,00	mm				
Tebal efektif,		d = h - p	=	1900	mm	Luas tulangan yang digunakan,			=	3801,33	mm <sup>2</sup>				
Lebar yang ditinjau,		b	=	1000	mm	D		22	=	-	100				
Modulus elastis baja,		Es	=	2.E+05		<b>Tulangan Bagi :</b>									
Faktor bentuk distribusi tegangan beton,		β <sub>1</sub>	=	0,85		Luas tulangan,		As,b = 20 % . As,u	=	634,21	mm <sup>2</sup>				
Faktor reduksi kekuatan lentur,		φ	=	0,80		Diameter tulangan,		d	=	16	mm				
Momen tumpuan, K =		$\frac{Mu}{\phi \cdot bd^2}$	=	0,40	MPa	Jarak tulangan yang diperlukan,			=	317,03	mm				
						Jarak tulangan yang digunakan,			=	300,00	mm				
						Luas tulangan yang digunakan,			=	670,21	mm <sup>2</sup>				
						D		16	=	-	300				
Kmaks =	$382,5 \beta_1 . fc' . (600 + fy - 225 \beta_1) / (600 + fy)^2$		=	5,98	MPa	<b>Tulangan Tekan</b>									
						<b>Tulangan Utama :</b>									
						Luas tulangan,		As,u = 50% .As,u tarik	=	1585,53	mm <sup>2</sup>				
						Diameter tulangan,		d	=	16	mm				
						Jarak tulangan yang diperlukan,			=	126,81	mm				
						Jarak tulangan yang digunakan,			=	125,00	mm				
						Luas tulangan yang digunakan,			=	1608,50	mm <sup>2</sup>				
						D		16	=	-	125				
						<b>Tulangan Bagi :</b>									
						Luas tulangan, As,b = 20 % . As,u			=	317,11	mm <sup>2</sup>				
						Diameter tulangan,		d	=	8	mm				
						Jarak tulangan yang diperlukan,			=	158,51	mm				
						Jarak tulangan yang digunakan,			=	150,00	mm				
						Luas tulangan yang digunakan,			=	335,10	mm <sup>2</sup>				
						D		8	=	-	150				

Sumber : Hasil Perhitungan

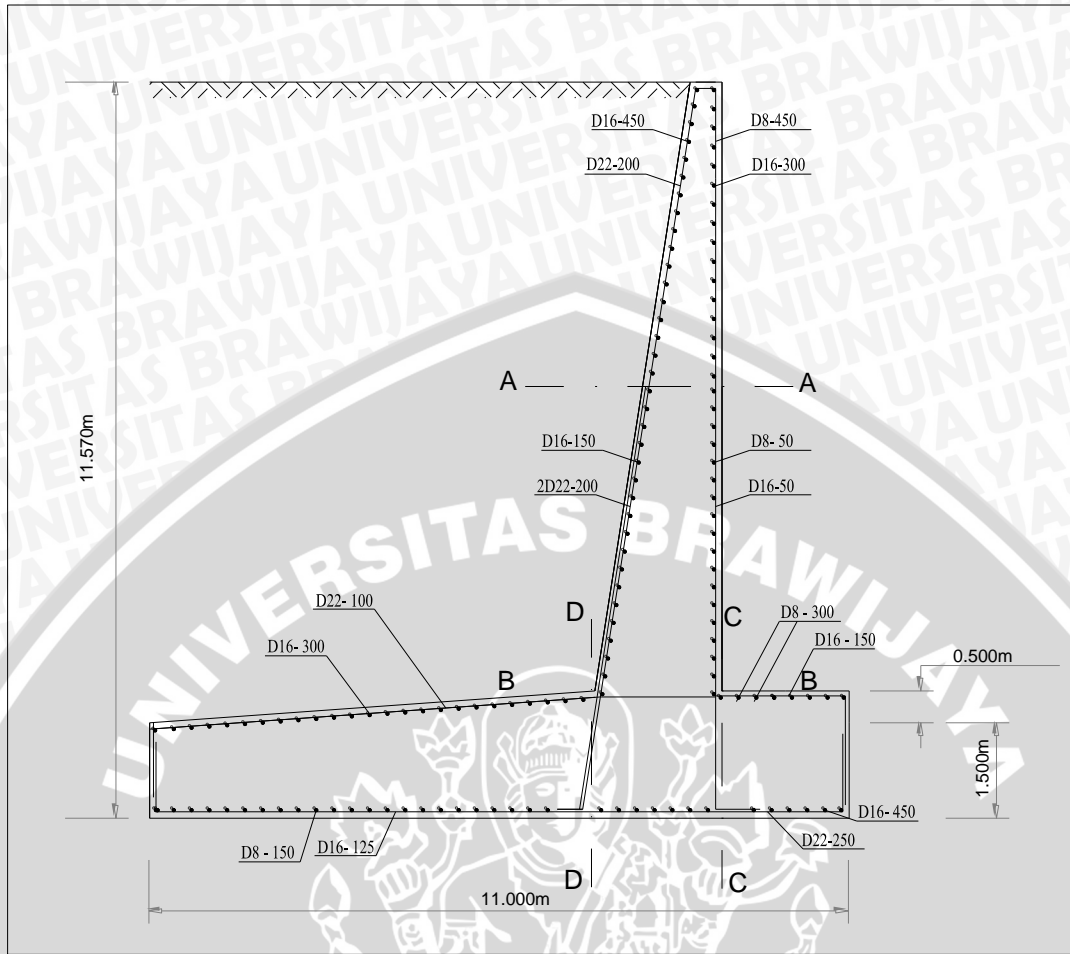

**Gambar 4.74. Penulangan Pada Dinding Penahan Bagian Hulu**

**4.5.4. Dinding Penahan Bagian Jembatan**

Perhitungan bending momen dinding penahan jembatan kondisi muka air banjir (gempa) dapat dilihat pada Tabel 4.65 sampai Tabel 4.68 dan diagram gaya dan momen yang bekerja pada dinding penahan dapat dilihat pada Gambar 4.75 sampai Gambar 4.78. Gambar detail penulangan pada dinding penahan bagian jembatan dapat dilihat pada Gambar 4.79.

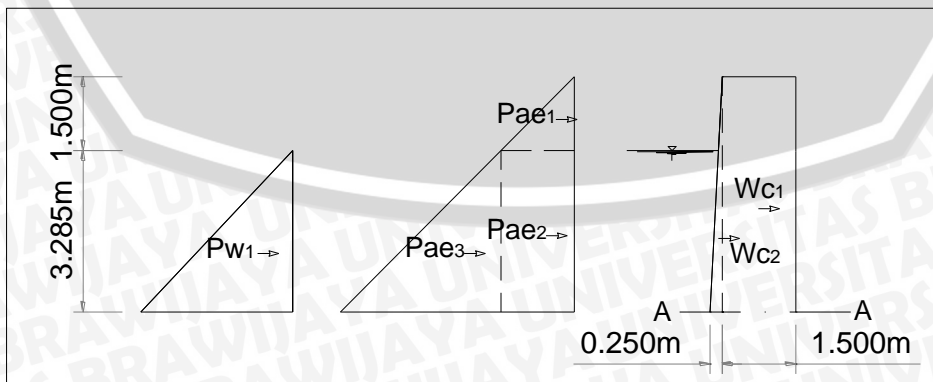

**Gambar 4.75. Bending Momen Dinding Penahan Jembatan Potongan A-A Kondisi Muka Air Banjir (Gempa)**

**Tabel 4.65. Perhitungan Bending Momen Dinding Penahan Jembatan Potongan A-A Kondisi Muka Air Banjir Gempa**

No.	Notasi	Tekanan / Luas penampang								Gaya ( ton )	Lengan Y ( m )	Momen ( ton.m )					
1	PaeH <sub>1</sub>	1,200	x	0,500	x	Kae	x	h <sub>1</sub>	x	h <sub>1</sub>	x	γ	1,047	3,785	3,963		
		1,200	x	0,500	x	0,431	x	1,500	x	1,500	x	1,800					
2	PaeH <sub>2</sub>	1,200	x	Kae	x	γ <sub>sub</sub>	x	h <sub>1</sub>	x	h <sub>2</sub>			2,488	1,643	4,086		
		1,200	x	0,431	x	0,976	x	1,500	x	3,285							
3	PaeH <sub>3</sub>	1,200	x	0,500	x	Kae	x	h <sub>2</sub>	x	h <sub>2</sub>	x	γ <sub>sub</sub>	2,724	1,095	2,983		
		1,200	x	0,500	x	0,431	x	3,285	x	3,285	x	0,976					
7	Wc <sub>1</sub>	1,200	x	Lebar	x	Tinggi	x	Panjang	x	Rasio	x	γ	x	Kh	3,101	2,393	7,418
		1,200	x	1,500	x	4,785	x	1,000	x	1,000	x	2,400	x	0,150			
8	Wc <sub>2</sub>	1,200	x	0,250	x	4,785	x	1,000	x	0,500	x	2,400	x	0,150	0,258	1,595	0,412
9	Pw <sub>1</sub>	1,200	x	0,500	x	h <sub>2</sub>	x	h <sub>2</sub>	x	γ <sub>w</sub>			6,475	1,095	7,090		
		1,200	x	0,500	x	3,285	x	3,285	x	1,000							
Total										16,092		25,952					

Momen rencana ultimit, Mu = 259,52 kNm	<b>Tulangan Tarik</b>
Gaya vertikal rencana ultimit, Pu = 160,92 kN	<b>Tulangan Utama :</b>
Mutu beton, f <sub>c</sub> ' = 20 MPa	Luas tulangan, = 822,08 mm <sup>2</sup>
Mutu Baja, f <sub>y</sub> = 240 MPa	Diameter tulangan, d = 22 mm
Tebal beton, h = 1750 mm	Jarak tulangan yang diperlukan, = 462,41 mm
Selimit beton, p = 100 mm	Jarak tulangan yang digunakan, = 200,00 mm
Tebal efektif, d = h - p = 1650 mm	Luas tulangan yang digunakan, = 1900,66 mm <sup>2</sup>
Lebar yang ditinjau, b = 1000 mm	D 22 - 200
Modulus elastis baja, E <sub>s</sub> = 2,0E+05	<b>Tulangan Bagi :</b>
Faktor bentuk distribusi tegangan beton, β <sub>1</sub> = 0,85	Luas tulangan, A <sub>s,b</sub> = 20 % . A <sub>s,u</sub> = 164,42 mm <sup>2</sup>
Faktor reduksi kekuatan lentur, φ = 0,80	Diameter tulangan, d = 16 mm
Momen tumpuan, K = $\frac{Mu}{\phi \cdot bd^2}$ = 0,119 MPa	Jarak tulangan yang diperlukan, = 1222,89 mm
	Jarak tulangan yang digunakan, = 450,00 mm
	Luas tulangan yang digunakan, = 446,80 mm <sup>2</sup>
	D 16 - 450
Kmaks = $\frac{382,5 \cdot \beta_1 \cdot f_c' \cdot (600 + f_y - 225 \cdot \beta_1)}{(600 + f_y)^2}$ = 5,98 MPa	<b>Tulangan Tekan</b>
	<b>Tulangan Utama :</b>
	Luas tulangan, A <sub>s,u</sub> = 50% . A <sub>s,u</sub> tarik = 411,04 mm <sup>2</sup>
	Diameter tulangan, d = 16 mm
	Jarak tulangan yang diperlukan, = 489,16 mm
	Jarak tulangan yang digunakan, = 450,00 mm
	Luas tulangan yang digunakan, = 446,80 mm <sup>2</sup>
	D 16 - 450
	<b>Tulangan Bagi :</b>
	Luas tulangan, A <sub>s,b</sub> = 20 % . A <sub>s,u</sub> = 82,21 mm <sup>2</sup>
	Diameter tulangan, d = 8 mm
	Jarak tulangan yang diperlukan, = 611,45 mm
	Jarak tulangan yang digunakan, = 450,00 mm
	Luas tulangan yang digunakan, = 111,70 mm <sup>2</sup>
	D 8 - 450

Sumber: Hasil Perhitungan

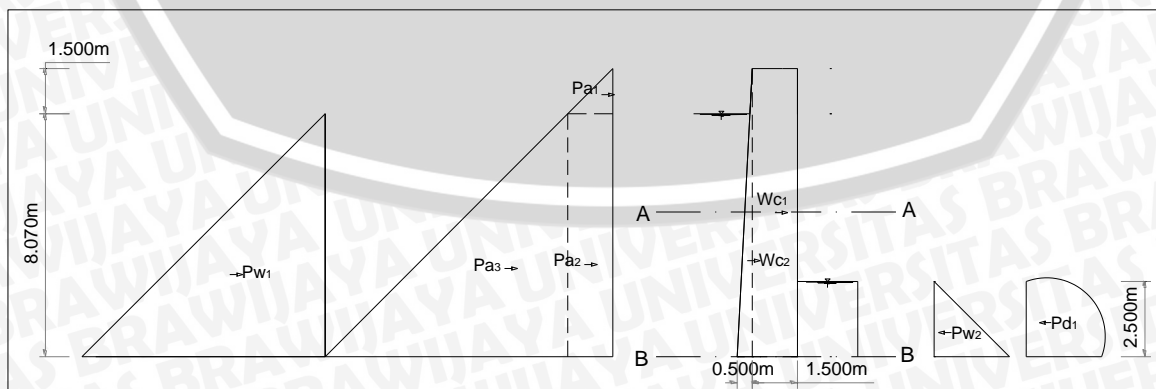

**Gambar 4.76. Bending Momen Dinding Penahan Jembatan Potongan B-B Kondisi Muka Air Banjir (Gempa)**

**Tabel 4.66. Perhitungan Bending Momen Dinding Penahan Jembatan Potongan B-B Kondisi Muka Air Banjir Gempa**

No.	Notasi	Tekanan / Luas penampang										Gaya (ton)	Lengan (m)	Momen (ton.m)			
1	PaeH <sub>1</sub>	1,200	x	0,500	x	Kae	x	h <sub>1</sub>	x	h <sub>1</sub>	x	γ	1,047	8,570	8,972		
2	PaeH <sub>2</sub>	1,200	x	0,500	x	0,431	x	1,500	x	1,500	x	1,800					
3	PaeH <sub>3</sub>	1,200	x	0,431	x	1,500	x	8,070	x	1,800			11,265	4,035	45,455		
		1,200	x	0,500	x	Kae	x	h <sub>2</sub>	x	h <sub>2</sub>	x	γ <sub>sub</sub>					
4	Pw <sub>1</sub>	1,200	x	0,500	x	0,431	x	8,070	x	8,070	x	0,976	16,439	2,690	44,221		
		1,200	x	0,500	x	h <sub>2</sub>	x	h <sub>2</sub>	x	γ <sub>w</sub>							
5	Pw <sub>2</sub>	1,200	x	0,500	x	8,070	x	8,070	x	1,000			39,075	2,690	105,112		
		1,200	x	0,500	x	h <sub>3</sub>	x	h <sub>3</sub>	x	γ <sub>w</sub>							
6	Pd <sub>1</sub>	1,200	x	0,500	x	2,500	x	2,500	x	1,000			-3,750	0,833	-3,125		
		1,200	x	(7/12)	x	h <sub>3</sub>	x	h <sub>3</sub>	x	γ <sub>w</sub>	x	kh					
7	Wc <sub>1</sub>	1,200	x	0,583	x	2,500	x	2,500	x	1,000	x	0,150	-0,656	0,833	-0,547		
		1,200	x	Lebar	x	Tinggi	x	Panjang	x	Rasio	x	γ <sub>beton</sub>				x	kh
7	Wc <sub>2</sub>	1,200	x	1,500	x	9,570	x	1,000	x	1,000	x	2,400	x	0,150	6,201	4,785	29,674
		1,200	x	0,500	x	9,570	x	1,000	x	0,500	x	2,400	x	0,150			
Total											70,655		233,059				

Momen rencana ultimit,	Mu	=	2330,59	kNm	<b>Tulangan Tarik</b>					
Gaya vertikal rencana ultimit,	Pu	=	706,55	kN	<b>Tulangan Utama :</b>					
Mutu beton,	Kuat tekan beton	fc'	=	20,0	MPa	Luas tulangan,	=	6547,97	mm <sup>2</sup>	
Mutu Baja,	Tegangan leleh baja	fy	=	240,0	MPa	Diameter tulangan,	d	=	22	mm
Tebal beton,		h	=	2000	mm	Jarak tulangan yang diperlukan,		=	58,05	mm
Selimut beton,		p	=	100	mm	Jarak tulangan yang digunakan,		=	100,00	mm
Tebal efektif,		d = h - p	=	1900	mm	Luas tulangan yang digunakan,		=	7602,65	mm <sup>2</sup>
Lebar yang ditinjau,		b	=	1000	mm		2D	22	-	200
Modulus elastis baja,		Es	=	2.E+05		<b>Tulangan Bagi :</b>				
Faktor bentuk distribusi tegangan beton,		β <sub>1</sub>	=	0,85		Luas tulangan,	As,b = 20 % . As,u	=	1309,59	mm <sup>2</sup>
Faktor reduksi kekuatan lentur,		φ	=	0,80		Diameter tulangan,	d	=	16	mm
Momen tumpuan, K =		$\frac{Mu}{\phi \cdot bd^2}$	=	0,807	MPa	Jarak tulangan yang diperlukan,		=	153,53	mm
						Jarak tulangan yang digunakan,		=	150,00	mm
						Luas tulangan yang digunakan,		=	1340,41	mm <sup>2</sup>
							D	16	-	150
Kmaks = $\frac{382,5 \cdot \beta_1 \cdot fc' \cdot (600 + fy - 225 \cdot \beta_1)}{(600 + fy)^2}$			=	5,98	MPa	<b>Tulangan Tekan</b>				
						<b>Tulangan Utama :</b>				
						Luas tulangan,	As,u = 50% . As,u tarik	=	3273,99	mm <sup>2</sup>
						Diameter tulangan,	d	=	16	mm
						Jarak tulangan yang diperlukan,		=	61,41	mm
						Jarak tulangan yang digunakan,		=	50,00	mm
						Luas tulangan yang digunakan,		=	4021,24	mm <sup>2</sup>
							D	16	-	50
						<b>Tulangan Bagi :</b>				
						Luas tulangan, As,b = 20 % . As,u		=	654,80	mm <sup>2</sup>
						Diameter tulangan,	d	=	8	mm
						Jarak tulangan yang diperlukan,		=	76,76	mm
						Jarak tulangan yang digunakan,		=	50,00	mm
						Luas tulangan yang digunakan,		=	1005,31	mm <sup>2</sup>
							D	8	-	50

Sumber: Hasil Perhitungan

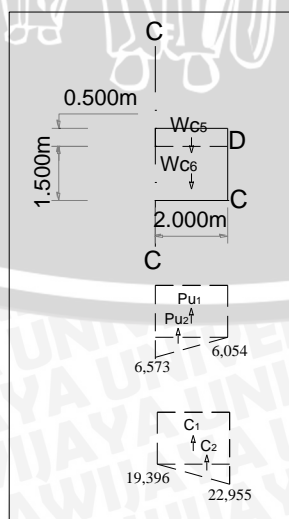

**Gambar 4.77. Bending Momen Dinding Penahan Jembatan Potongan C-C Kondisi Muka Air Banjir (Gempa)**

**Tabel 4.67. Perhitungan Bending Momen Dinding Penahan Jembatan Potongan C-C Kondisi Muka Air Banjir Gempa**

No.	Notasi	Tekanan / Luas penampang										Gaya (ton)	Lengan X (m)	Momen (ton.m)				
1	Wc <sub>5</sub> Wc <sub>6</sub>	1,200	x	Lebar	x	Tinggi	x	Panjang	x	rasio	x	γ	2,880	0,667	1,920			
		1,200	x	2,000	x	0,500	x	1,000	x	1,000	x	2,400				8,640	1,000	8,640
		1,200	x	2,000	x	1,500	x	1,000	x	1,000	x	2,400						
2	Pu <sub>1</sub> Pu <sub>2</sub>	1,200	x	Lebar	x	Tinggi	x	Panjang	x	rasio	x	γ	-14,531	1,000	-14,531			
		1,200	x	2,000	x	6,054	x	1,000	x	1,000	x	1,000				-0,622	1,333	-0,829
		1,200	x	2,000	x	0,518	x	1,000	x	0,500	x	1,000						
3	C <sub>1</sub> C <sub>2</sub>	1,200	x	Lebar	x	Tinggi	x	Panjang	x	rasio			-46,549	1,000	-46,549			
		1,200	x	2,000	x	19,396	x	1,000	x	1,000						-4,271	1,333	-5,694
		1,200	x	2,000	x	3,559	x	1,000	x	0,500								
<b>Total</b>											-54,453		-57,044					
Momen rencana ultimit, Mu =		570,44		kNm		<b>Tulangan Tarik</b>												
Gaya vertikal rencana ultimit, Pu =		544,53		kN		<b>Tulangan Utama :</b>												
Mutu beton, Kuat tekan beton, fc' =		20,0		MPa		Luas tulangan, =						1572,88 mm <sup>2</sup>						
Mutu Baja, Tegangan leleh baja, fy =		240,0		MPa		Diameter tulangan, d =						22 mm						
Tebal beton, h =		2000		mm		Jarak tulangan yang diperlukan, =						241,68 mm						
Selimut beton, p =		100		mm		Jarak tulangan yang digunakan, =						200,00 mm						
Tebal efektif, d = h - p =		1900		mm		Luas tulangan yang digunakan, =						1900,66 mm <sup>2</sup>						
Lebar yang ditinjau, b =		1000		mm		Luas tulangan yang digunakan, D =						22 - 200						
Modulus elastis baja, Es =		2.E+05				<b>Tulangan Bagi :</b>												
Faktor bentuk distribusi tegangan beton, β <sub>1</sub> =		0,85				Luas tulangan, As,b = 20 % . As,u =						314,58 mm <sup>2</sup>						
Faktor reduksi kekuatan lentur, φ =		0,80				Diameter tulangan, d =						16 mm						
Momen tumpuan, K = $\frac{Mu}{\phi \cdot bd^2}$		0,20		MPa		Jarak tulangan yang diperlukan, =						639,15 mm						
Kmaks = $\frac{382,5 \cdot \beta_1 \cdot fc' \cdot (600 + fy - 225 \cdot \beta_1)}{(600 + fy)^2}$		5,98		MPa		Jarak tulangan yang digunakan, =						450,00 mm						
a = $(1 - (1 - \frac{2K}{0,85 \cdot fc'})^{0,5}) \cdot d$		22,21		mm		Luas tulangan yang digunakan, =						446,80 mm <sup>2</sup>						
						Luas tulangan yang digunakan, D =						16 - 450						
						<b>Tulangan Tekan</b>												
						<b>Tulangan Utama :</b>												
						Luas tulangan, As,u = 50% . As,u tarik =						786,44 mm <sup>2</sup>						
						Diameter tulangan, d =						16 mm						
						Jarak tulangan yang diperlukan, =						255,66 mm						
						Jarak tulangan yang digunakan, =						250,00 mm						
						Luas tulangan yang digunakan, =						804,25 mm <sup>2</sup>						
						Luas tulangan yang digunakan, D =						16 - 250						
						<b>Tulangan Bagi :</b>												
						Luas tulangan, As,b = 20 % . As,u =						157,29 mm <sup>2</sup>						
						Diameter tulangan, d =						8 mm						
						Jarak tulangan yang diperlukan, =						319,58 mm						
						Jarak tulangan yang digunakan, =						300,00 mm						
						Luas tulangan yang digunakan, =						167,55 mm <sup>2</sup>						
						Luas tulangan yang digunakan, D =						8 - 300						

Sumber: Hasil Perhitungan

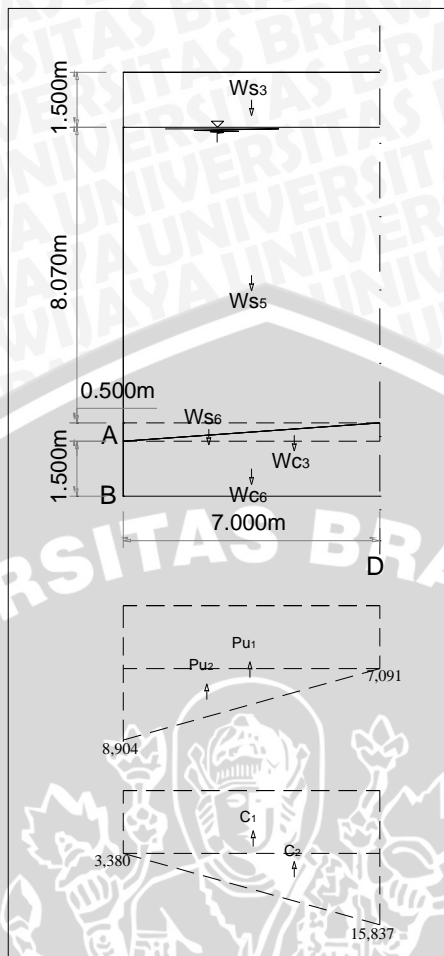

**Gambar 4.78. Bending Momen Dinding Penahan Jembatan Potongan D-D Kondisi Muka Air Banjir (Gempa)**

**Tabel 4.68. Perhitungan Bending Momen Dinding Penahan Jembatan Potongan D-D Kondisi Muka Air Banjir Gempa**

No.	Notasi	Tekanan / Luas penampang										Gaya (ton)	Lengan X (m)	Momen (ton.m)		
1	Wc <sub>3</sub>	1,200	x	Lebar	x	Tinggi	x	Panjang	x	rasio	x	γ	5,040	2,333	11,760	
	Wc <sub>6</sub>	1,200	x	7,000	x	0,500	x	1,000	x	0,500	x	2,400	30,240	3,500	105,840	
		1,200	x	7,000	x	1,500	x	1,000	x	1,000	x	2,400				
2	Ws <sub>3</sub>	1,200	x	Lebar	x	Tinggi	x	Panjang	x	rasio	x	γ	11,340	3,500	39,690	
	Ws <sub>5</sub>	1,200	x	7,000	x	1,500	x	1,000	x	0,500	x	1,800	133,981	3,500	468,933	
	Ws <sub>6</sub>	1,200	x	7,000	x	8,070	x	1,000	x	1,000	x	1,976	4,151	4,667	19,369	
3	Pu <sub>1</sub>	1,200	x	Lebar	x	Tinggi	x	Panjang	x	rasio			-59,562	3,500	-208,467	
	Pu <sub>2</sub>	1,200	x	7,000	x	7,091	x	1,000	x	1,000			-7,617	4,667	-35,544	
		1,200	x	7,000	x	1,813	x	1,000	x	0,500						
4	C <sub>1</sub>	1,200	x	Lebar	x	Tinggi	x	Panjang	x	rasio			-28,393	3,500	-99,375	
	C <sub>2</sub>	1,200	x	7,000	x	3,380	x	1,000	x	1,000			-52,317	3,500	-183,111	
		1,200	x	7,000	x	12,457	x	1,000	x	0,500						
<b>Total</b>											<b>36,863</b>		<b>119,096</b>			
Momen rencana ultimit,		Mu	=	1190,96	kNm	<b>Tulangan Tarik</b>										
Gaya vertikal rencana ultimit,		Pu	=	368,63	kN	<b>Tulangan Utama :</b>										
Mutu beton,		Kuat tekan beton	fc'	=	20,0	MPa	Luas tulangan,						=	3305,29	mm <sup>2</sup>	
Mutu Baja,		Tegangan leleh baja	fy	=	240	MPa	Diameter tulangan,						d	=	22	mm
Tebal beton,			h	=	2000	mm	Jarak tulangan yang diperlukan,							=	115,01	mm
Selimut beton,			p	=	100	mm	Jarak tulangan yang digunakan,							=	100,00	mm
Tebal efektif,			d = h - p	=	1900	mm	Luas tulangan yang digunakan,							=	3801,33	mm <sup>2</sup>
Lebar yang ditinjau,			b	=	1000	mm	D						22	-	100	
Modulus elastis baja,			Es	=	2,E+05		<b>Tulangan Bagi :</b>									
Faktor bentuk distribusi tegangan beton,			β <sub>1</sub>	=	0,85		Luas tulangan,						As,b = 20 % .As,u	=	661,06	mm <sup>2</sup>
Faktor reduksi kekuatan lentur,			φ	=	0,80		Diameter tulangan,						d	=	16	mm
Momen tumpuan, K =			$\frac{Mu}{\phi .bd^2}$	=	0,41	MPa	Jarak tulangan yang diperlukan,							=	304,15	mm
				=	5,98	MPa	Jarak tulangan yang digunakan,							=	300,00	mm
				=			Luas tulangan yang digunakan,							=	670,21	mm <sup>2</sup>
Kmaks =			$\frac{382,5 . \beta_1 . fc' . (600 + fy - 225 . \beta_1)}{(600 + fy)^2}$	=			D						16	-	300	
a = (1 - (1 -			$\frac{2K}{0,85 . fc'}$ ) <sup>0,5</sup> . d	=	46,66	mm	<b>Tulangan Tekan</b>									
				=			<b>Tulangan Utama :</b>									
				=			Luas tulangan,						As,u = 50% .As,u tarik	=	1652,64	mm <sup>2</sup>
				=			Diameter tulangan,						d	=	16	mm
				=			Jarak tulangan yang diperlukan,							=	121,66	mm
				=			Jarak tulangan yang digunakan,							=	100,00	mm
				=			Luas tulangan yang digunakan,							=	2010,62	mm <sup>2</sup>
				=			D						16	-	100	
				=			<b>Tulangan Bagi :</b>									
				=			Luas tulangan, As,b = 20 % .As,u							=	330,53	mm <sup>2</sup>
				=			Diameter tulangan,						d	=	8	mm
				=			Jarak tulangan yang diperlukan,							=	152,08	mm
				=			Jarak tulangan yang digunakan,							=	150,00	mm
				=			Luas tulangan yang digunakan,							=	335,10	mm <sup>2</sup>
				=			D						8	-	150	

Sumber: Hasil Perhitungan



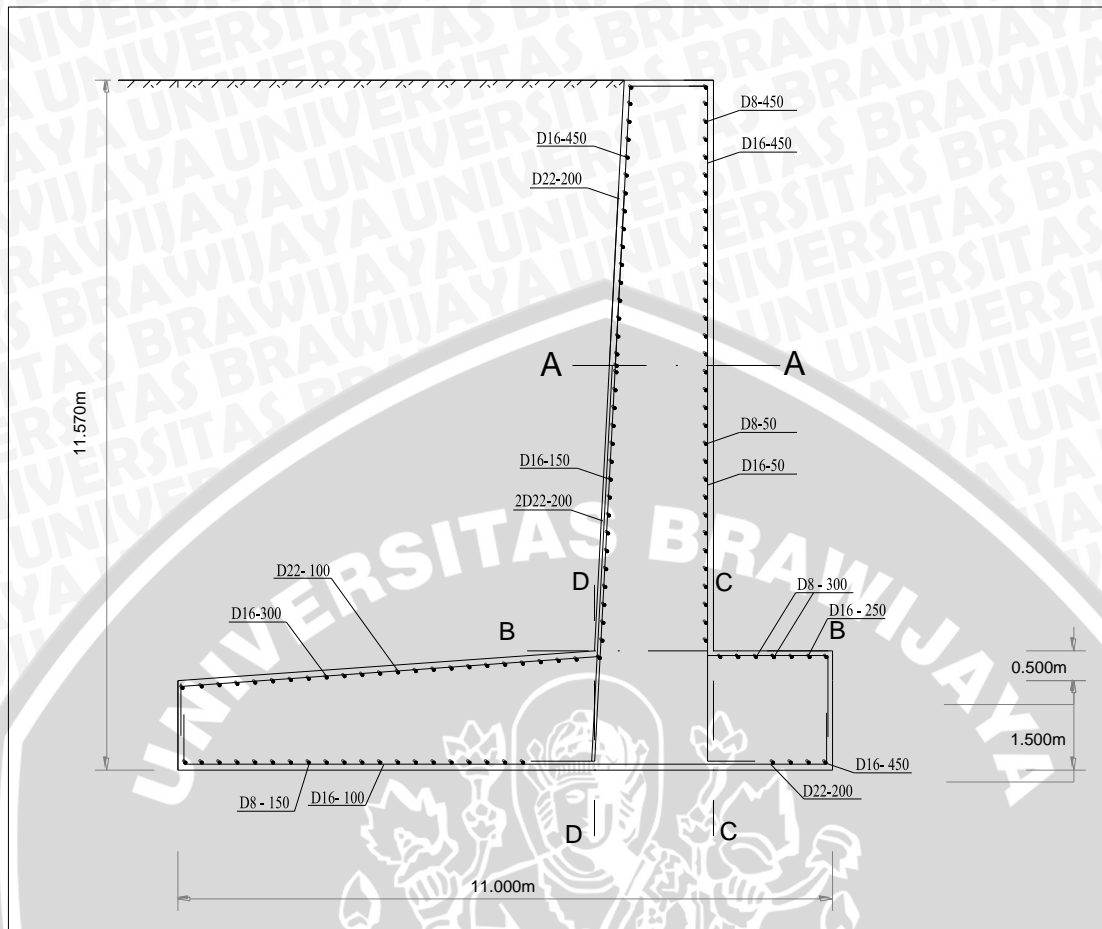

**Gambar 4.79. Penulangan Pada Dinding Penahan Bagian Jembatan**

**4.5.5. Dinding Penahan Bagian Hilir**

Perhitungan bending momen dinding penahan hilir kondisi muka air banjir (gempa) dapat dilihat pada Tabel 4.69 sampai Tabel 4.72 dan diagram gaya dan momen yang bekerja pada dinding penahan dapat dilihat pada Gambar 4.80 sampai Gambar 4.83. Gambar detail penulangan pada dinding penahan bagian hilir dapat dilihat pada Gambar 4.84.

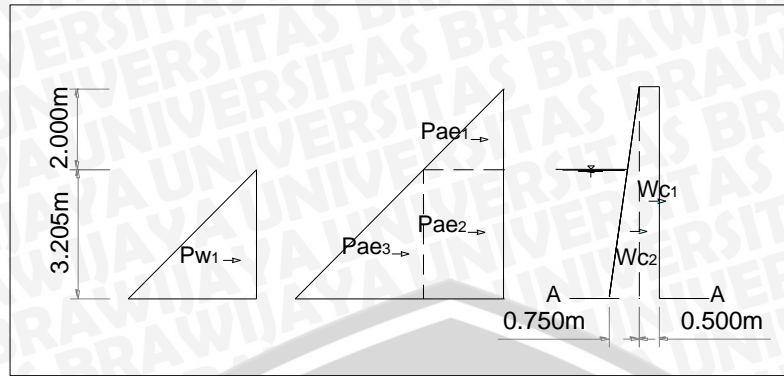

**Gambar 4.80. Bending Momen Dinding Penahan Bagian Hilir Potongan A-A Kondisi Muka Air Banjir (Gempa)**

**Tabel 4.69. Bending Momen Dinding Penahan Hilir Potongan A-A Kondisi Muka Air Banjir Gempa**

No.	Notasi	Tekanan / Luas penampang										Gaya (ton)	Lengan Y (m)	Momen (ton.m)			
1	PaeH <sub>1</sub>	1,200	x	0,500	x	Kae	x	h <sub>1</sub>	x	h <sub>1</sub>	x	γ	2,055	3,872	7,958		
		1,200	x	0,500	x	0,476	x	2,000	x	2,000	x	1,800					
2	PaeH <sub>2</sub>	1,200	x	Kae	x	γsub	x	h <sub>1</sub>	x	h <sub>2</sub>	3,574	1,603	5,727				
		1,200	x	0,476	x	0,976	x	2,000	x	3,205							
3	PaeH <sub>3</sub>	1,200	x	0,500	x	Kae	x	h <sub>2</sub>	x	h <sub>2</sub>	x	γsub	2,863	1,068	3,059		
		1,200	x	0,500	x	0,476	x	3,205	x	3,205	x	0,976					
7	Wc <sub>1</sub>	1,200	x	Lebar	x	Tinggi	x	Panjang	x	Rasio	x	γ	x	Kh	1,124	2,603	2,926
		1,200	x	0,500	x	5,205	x	1,000	x	1,000	x	2,400	x	0,150			
8	Wc <sub>2</sub>	1,200	x	0,750	x	5,205	x	1,000	x	0,500	x	2,400	x	0,150	0,843	1,735	1,463
		1,200	x	0,500	x	h <sub>2</sub>	x	h <sub>2</sub>	x	γw							
9	Pw <sub>1</sub>	1,200	x	0,500	x	h <sub>2</sub>	x	h <sub>2</sub>	x	γw	6,163	1,068	6,584				
		1,200	x	0,500	x	3,205	x	3,205	x	1,000							
Total												16,623		27,716			
Momen rencana ultimit, Mu = 277,16 kNm		<b>Tulangan Tarik</b>															
Gaya vertikal rencana ultimit, Pu = 166,23 kN		<b>Tulangan Utama :</b>															
Mutu beton, Kuat teka fc' = 20,0 MPa	Luas tulangan, = 1265,10 mm <sup>2</sup>																
Mutu Baja, Tegangan fy = 240 MPa	Diameter tulangan, d = 22 mm																
Tebal beton, h = 1250 mm	Jarak tulangan yang diperlukan, = 300,48 mm																
Selimut beton, p = 100 mm	Jarak tulangan yang digunakan, = 300,00 mm																
Tebal efektif, d = h - p = 1150 mm	Luas tulangan yang digunakan, = 1267,11 mm <sup>2</sup>																
Lebar yang ditinjau, b = 1000 mm	D 22 - 300																
Modulus elastis baja, Es = 2.E+05	<b>Tulangan Bagi :</b>																
Faktor bentuk distribusi tegangan b β <sub>1</sub> = 0,85	Luas tulangan, As,b = 20 % . As,u = 253,02 mm <sup>2</sup>																
Faktor reduksi kekuatan lentur, φ = 0,80	Diameter tulangan, d = 16 mm																
Momen tumpuan, K = $\frac{Mu}{\phi \cdot b \cdot d^2}$	Jarak tulangan yang diperlukan, = 794,65 mm																
	Jarak tulangan yang digunakan, = 300,00 mm																
	Luas tulangan yang digunakan, = 670,21 mm <sup>2</sup>																
Kmaks = $\frac{382,5 \cdot \beta_1 \cdot f_c'}{(600 + f_y)^2} \cdot (600 + f_y - 225 \cdot \beta_1)$	D 16 - 300																
a = (1 - (1 - $\frac{K}{K_{maks}}$ ) <sup>0,5</sup> ) d	<b>Tulangan Tekan</b>																
	<b>Tulangan Utama :</b>																
	Luas tulangan, As,u = 50% . As,u tarik = 632,55 mm <sup>2</sup>																
	Diameter tulangan, d = 16 mm																
	Jarak tulangan yang diperlukan, = 317,86 mm																
	Jarak tulangan yang digunakan, = 300,00 mm																
	Luas tulangan yang digunakan, = 670,21 mm <sup>2</sup>																
	D 16 - 300																
	<b>Tulangan Bagi :</b>																
	Luas tulangan, As,b = 20 % . As,u = 126,51 mm <sup>2</sup>																
	Diameter tulangan, d = 8 mm																
	Jarak tulangan yang diperlukan, = 397,33 mm																
	Jarak tulangan yang digunakan, = 300,00 mm																
	Luas tulangan yang digunakan, = 167,55 mm <sup>2</sup>																
	D 8 - 300																

Sumber: Hasil Perhitungan

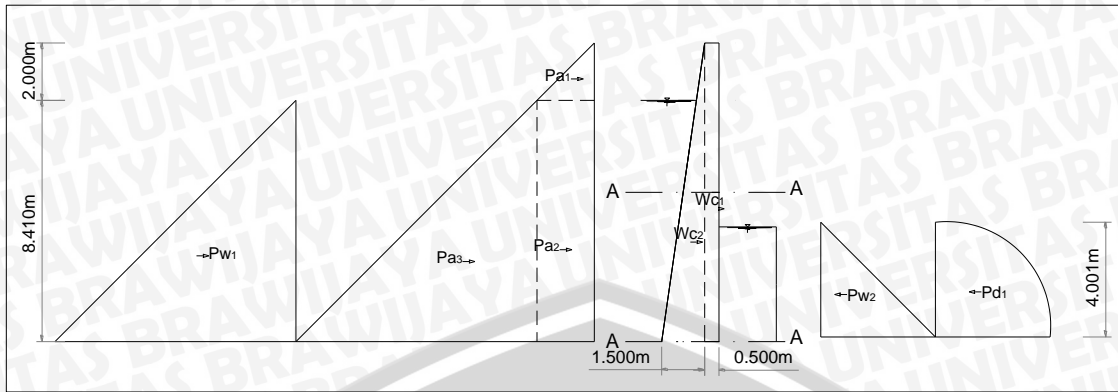

**Gambar 4.81. Bending Momen Dinding Penahan Bagian Hilir Potongan B-B Kondisi Muka Air Banjir (Gempa)**

**Tabel 4.70. Bending Momen Dinding Penahan Hilir Potongan B-B Kondisi Muka Air Banjir Gempa**

No.	Notasi	Tekanan / Luas penampang										Gaya (ton)	Lengan (m)	Momen (ton.m)			
1	PaeH <sub>1</sub>	1,200	x	0,500	x	Kae	x	h <sub>1</sub>	x	h <sub>1</sub>	x	γ	2,055	9,077	18,656		
2	PaeH <sub>2</sub>	1,200	x	0,500	x	0,476	x	2,000	x	2,000	x	1,800					
3	PaeH <sub>3</sub>	1,200	x	0,476	x	2,000	x	8,410	x	1,800			17,285	4,205	72,685		
		1,200	x	0,500	x	Kae	x	h <sub>2</sub>	x	h <sub>2</sub>	x	γ <sub>sub</sub>	19,715	2,803	55,268		
4	Pw <sub>1</sub>	1,200	x	0,500	x	0,476	x	8,410	x	8,410	x	0,976				42,437	2,803
5	Pw <sub>2</sub>	1,200	x	0,500	x	4,000	x	4,000	x	1,000			-9,600	1,333	-12,800		
6	Pd <sub>1</sub>	1,200	x	(7/12)	x	h <sub>3</sub>	x	h <sub>3</sub>	x	γ <sub>w</sub>	x	kh	-1,680	1,333	-2,240		
		1,200	x	0,583	x	4,000	x	4,000	x	1,000	x	0,150					
7	Wc <sub>1</sub>	1,200	x	Lebar	x	Tinggi	x	Panjang	x	Rasio	x	γ <sub>beton</sub>	x	kh	2,249	5,205	11,704
		1,200	x	0,500	x	10,410	x	1,000	x	1,000	x	2,400	x	0,150			
	Wc <sub>2</sub>	1,200	x	1,500	x	10,410	x	1,000	x	0,500	x	2,400	x	0,150	3,373	3,470	11,704
<b>Total</b>											<b>75,834</b>		<b>273,941</b>				
Momen rencana ultimit,		Mu		=		2739,41		kNm									
Gaya vertikal rencana ultimit,		Pu		=		758,34		kN									
Mutu beton,		Kuat tekan beton		fc'		=		20,0		MPa							
Mutu Baja,		Tegangan leleh baja		fy		=		240,0		MPa							
Tebal beton,		h		=		2000		mm									
Selimut beton,		p		=		100		mm									
Tebal efektif,		d = h - p		=		1900		mm									
Lebar yang ditinjau,		b		=		1000		mm									
Modulus elastis baja,		Es		=		2,E+05											
Faktor bentuk distribusi tegangan beton,		β <sub>1</sub>		=		0,85											
Faktor reduksi kekuatan lentur,		φ		=		0,80											
Momen tumpuan, K =		Mu		=		0,949		MPa									
		φ.bd <sup>2</sup>															
Kmaks =		382,5β <sub>1</sub> .fc'.(600 + fy - 225.β <sub>1</sub> )		=		5,98		MPa									
		(600 + fy) <sup>2</sup>															
a = (1 - (1 -		2K		) <sup>0,5</sup> . d		=		109,15		mm							
		0,85.fc'															
<b>Tulangan Tarik</b>																	
<b>Tulangan Utama :</b>																	
Luas tulangan,												=		7731,43 mm <sup>2</sup>			
Diameter tulangan,												d =		22 mm			
Jarak tulangan yang diperlukan,												=		49,17 mm			
Jarak tulangan yang digunakan,												=		75,00 mm			
Luas tulangan yang digunakan,												=		10136,87 mm <sup>2</sup>			
												2D		22 - 150			
<b>Tulangan Bagi :</b>																	
Luas tulangan, As,b = 20 % . As,u												=		1546,29 mm <sup>2</sup>			
Diameter tulangan,												d =		16 mm			
Jarak tulangan yang diperlukan,												=		130,03 mm			
Jarak tulangan yang digunakan,												=		100,00 mm			
Luas tulangan yang digunakan,												=		2010,62 mm <sup>2</sup>			
												D		16 - 100			
<b>Tulangan Tekan</b>																	
<b>Tulangan Utama :</b>																	
Luas tulangan, As,u = 50% .As,u tarik												=		3865,71 mm <sup>2</sup>			
Diameter tulangan,												d =		16 mm			
Jarak tulangan yang diperlukan,												=		52,01 mm			
Jarak tulangan yang digunakan,												=		50,00 mm			
Luas tulangan yang digunakan,												=		4021,24 mm <sup>2</sup>			
												D		16 - 50			
<b>Tulangan Bagi :</b>																	
Luas tulangan, As,b = 20 % . As,u												=		773,14 mm <sup>2</sup>			
Diameter tulangan,												d =		8 mm			
Jarak tulangan yang diperlukan,												=		65,01 mm			
Jarak tulangan yang digunakan,												=		50,00 mm			
Luas tulangan yang digunakan,												=		1005,31 mm <sup>2</sup>			
												D		8 - 50			

Sumber: Hasil Perhitungan



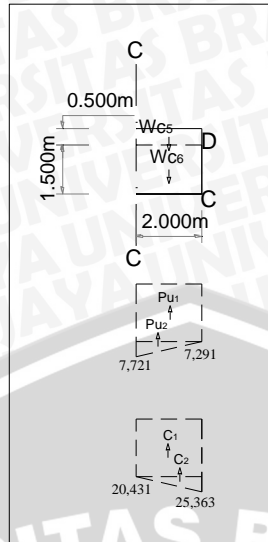

**Gambar 4.82. Bending Momen Dinding Penahan Bagian Hilir Potongan C-C Kondisi Muka Air Banjir (Gempa)**

**Tabel 4.71. Bending Momen Dinding Penahan Hilir Potongan C-C Kondisi Muka Air Banjir Gempa**

No.	Notasi	Tekanan / Luas penampang										Gaya ( ton )	Lengan X ( m )	Momen ( ton.m )	
1	Wc <sub>5</sub> Wc <sub>6</sub>	1,200	x	Lebar	x	Tinggi	x	Panjang	x	rasio	x	γ	2,880	0,667	1,920
		1,200	x	2,000	x	0,500	x	1,000	x	1,000	x	2,400	8,640	1,000	8,640
		1,200	x	2,000	x	1,500	x	1,000	x	1,000	x	2,400			
2	Pu <sub>1</sub> Pu <sub>2</sub>	1,200	x	Lebar	x	Tinggi	x	Panjang	x	rasio	x	γ	-17,498	1,000	-17,498
		1,200	x	2,000	x	7,291	x	1,000	x	1,000	x	1,000	-0,516	1,333	-0,688
		1,200	x	2,000	x	0,430	x	1,000	x	0,500	x	1,000			
3	C <sub>1</sub> C <sub>2</sub>	1,200	x	Lebar	x	Tinggi	x	Panjang	x	rasio		-49,034	1,000	-49,034	
		1,200	x	2,000	x	20,431	x	1,000	x	1,000		-5,919	1,333	-7,892	
		1,200	x	2,000	x	4,933	x	1,000	x	0,500					
<b>Total</b>											<b>-61,447</b>		<b>-64,552</b>		

Momen rencana ultimit,	Mu	=	645,52	kNm	<b>Tulangan Tarik</b>					
Gaya vertikal rencana ultimit,	Pu	=	614,47	kN	<b>Tulangan Utama :</b>					
Mutu beton,	Kuat tekan beton	fc'	=	20,0	MPa	Luas tulangan,	=	1781,31	mm <sup>2</sup>	
Mutu Baja,	Tegangan leleh baja	fy	=	240,0	MPa	Diameter tulangan,	d	=	22	mm
Tebal beton,		h	=	2000	mm	Jarak tulangan yang diperlukan,		=	213,40	mm
Selimut beton,		p	=	100	mm	Jarak tulangan yang digunakan,		=	200,00	mm
Tebal efektif,		d = h - p	=	1900	mm	Luas tulangan yang digunakan,		=	1900,66	mm <sup>2</sup>
Lebar yang ditinjau,		b	=	1000	mm		D	22	-	200
Modulus elastis baja,		Es	=	2,0E+05		<b>Tulangan Bagi :</b>				
Faktor bentuk distribusi tegangan beton,		β <sub>1</sub>	=	0,85		Luas tulangan,	As,b = 20 % . As,u	=	356,26	mm <sup>2</sup>
Faktor reduksi kekuatan lentur,		φ	=	0,80		Diameter tulangan,	d	=	16	mm
Momen tumpuan, K =		$\frac{Mu}{\phi \cdot bd^2}$	=	0,22	MPa	Jarak tulangan yang diperlukan,		=	564,37	mm
Kmaks =		$\frac{382,5 \cdot \beta_1 \cdot fc' \cdot (600 + fy - 225 \cdot \beta_1)}{(600 + fy)^2}$	=	5,98	MPa	Jarak tulangan yang digunakan,		=	450,00	mm
						Luas tulangan yang digunakan,		=	446,80	mm <sup>2</sup>
							D	16	-	450
						<b>Tulangan Tekan</b>				
						<b>Tulangan Utama :</b>				
						Luas tulangan,	As,u = 50% .As,u tarik	=	890,66	mm <sup>2</sup>
						Diameter tulangan,	d	=	16	mm
						Jarak tulangan yang diperlukan,		=	225,75	mm
						Jarak tulangan yang digunakan,		=	200,00	mm
						Luas tulangan yang digunakan,		=	1005,31	mm <sup>2</sup>
							D	16	-	200
						<b>Tulangan Bagi :</b>				
						Luas tulangan, As,b = 20 % . As,u		=	178,13	mm <sup>2</sup>
						Diameter tulangan,	d	=	8	mm
						Jarak tulangan yang diperlukan,		=	282,18	mm
						Jarak tulangan yang digunakan,		=	250,00	mm
						Luas tulangan yang digunakan,		=	201,06	mm <sup>2</sup>
							D	8	-	250

Sumber: Hasil Perhitungan

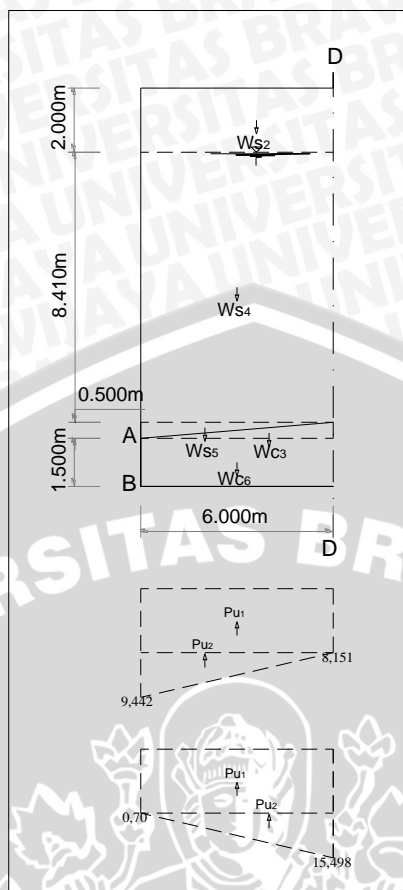

**Gambar 4.83. Momen Dinding Penahan Bagian Hilir Potongan D-D Kondisi Muka Air Banjir (Gempa)**

**Tabel 4.72. Bending Momen Dinding Penahan Hilir Potongan D-D Kondisi Muka Air Banjir Gempa**

No.	Notasi	Tekanan / Luas penampang										Gaya (ton)	Lengan X (m)	Momen (ton.m)	
1	Wc <sub>3</sub>	1,200	x	Lebar	x	Tinggi	x	Panjang	x	rasio	x	γ	4,320	2,000	8,640
	Wc <sub>6</sub>	1,200	x	6,000	x	0,500	x	1,000	x	0,500	x	2,400	25,920	3,000	77,760
2	Ws <sub>3</sub>	1,200	x	Lebar	x	Tinggi	x	Panjang	x	rasio	x	γ	12,960	3,000	38,880
	Ws <sub>5</sub>	1,200	x	6,000	x	2,000	x	1,000	x	0,500	x	1,800	119,679	3,000	359,038
	Ws <sub>6</sub>	1,200	x	6,000	x	0,500	x	1,000	x	0,500	x	1,976	3,558	4,000	14,231
3	Pu <sub>1</sub>	1,200	x	Lebar	x	Tinggi	x	Panjang	x	rasio			-58,689	3,000	-176,066
	Pu <sub>2</sub>	1,200	x	6,000	x	8,151	x	1,000	x	1,000			-4,647	4,000	-18,587
4	C <sub>1</sub>	1,200	x	Lebar	x	Tinggi	x	Panjang	x	rasio			-5,043	3,000	-15,130
	C <sub>2</sub>	1,200	x	6,000	x	0,700	x	1,000	x	1,000			-53,272	3,000	-159,815
Total											44,786		128,950		

Momen rencana ultimit,	Mu	=	1289,50	kNm	<b>Tulangan Tarik</b>					
Gaya vertikal rencana ultimit,	Pu	=	447,86	kN	<b>Tulangan Utama :</b>					
Mutu beton,	Kuat tekan beton	fc'	=	20,0	MPa	Luas tulangan,	=	3582,48	mm <sup>2</sup>	
Mutu Baja,	Tegangan leleh baja	fy	=	240	MPa	Diameter tulangan,	d	=	22	mm
Tebal beton,		h	=	2000	mm	Jarak tulangan yang diperlukan,		=	106,11	mm
Selimit beton,		p	=	100	mm	Jarak tulangan yang digunakan,		=	100,00	mm
Tebal efektif,		d = h - p	=	1900	mm	Luas tulangan yang digunakan,		=	3801,33	mm <sup>2</sup>
Lebar yang ditinjau,		b	=	1000	mm		D	22	-	100
Modulus elastis baja,		Es	=	2.E+05		<b>Tulangan Bagi :</b>				
Faktor bentuk distribusi tegangan beton,		β <sub>1</sub>	=	0,85		Luas tulangan,	As,b = 20 % . As,u	=	716,50	mm <sup>2</sup>
Faktor reduksi kekuatan lentur,		φ	=	0,80		Diameter tulangan,	d	=	16	mm
Momen tumpuan, K =		$\frac{Mu}{\phi \cdot bd^2}$	=	0,45	MPa	Jarak tulangan yang diperlukan,		=	280,62	mm
			=	5,98	MPa	Jarak tulangan yang digunakan,		=	250,00	mm
						Luas tulangan yang digunakan,		=	804,25	mm <sup>2</sup>
Kmaks =		$\frac{382,5 \cdot \beta_1 \cdot fc' \cdot (600 + fy - 225 \cdot \beta_1)}{(600 + fy)^2}$					D	16	-	250
a = ( 1 - (1 -		$\frac{2K}{0,85 \cdot fc'}$ ) <sup>0,5</sup>				<b>Tulangan Tekan</b>				
						<b>Tulangan Utama :</b>				
						Luas tulangan,	As,u = 50% . As,u tarik	=	1791,24	mm <sup>2</sup>
						Diameter tulangan,	d	=	16	mm
						Jarak tulangan yang diperlukan,		=	112,25	mm
						Jarak tulangan yang digunakan,		=	100,00	mm
						Luas tulangan yang digunakan,		=	2010,62	mm <sup>2</sup>
							D	16	-	100
						<b>Tulangan Bagi :</b>				
						Luas tulangan, As,b = 20 % . As,u		=	358,25	mm <sup>2</sup>
						Diameter tulangan,	d	=	8	mm
						Jarak tulangan yang diperlukan,		=	140,31	mm
						Jarak tulangan yang digunakan,		=	100,00	mm
						Luas tulangan yang digunakan,		=	502,65	mm <sup>2</sup>
							D	8	-	100

Sumber: Hasil Perhitungan

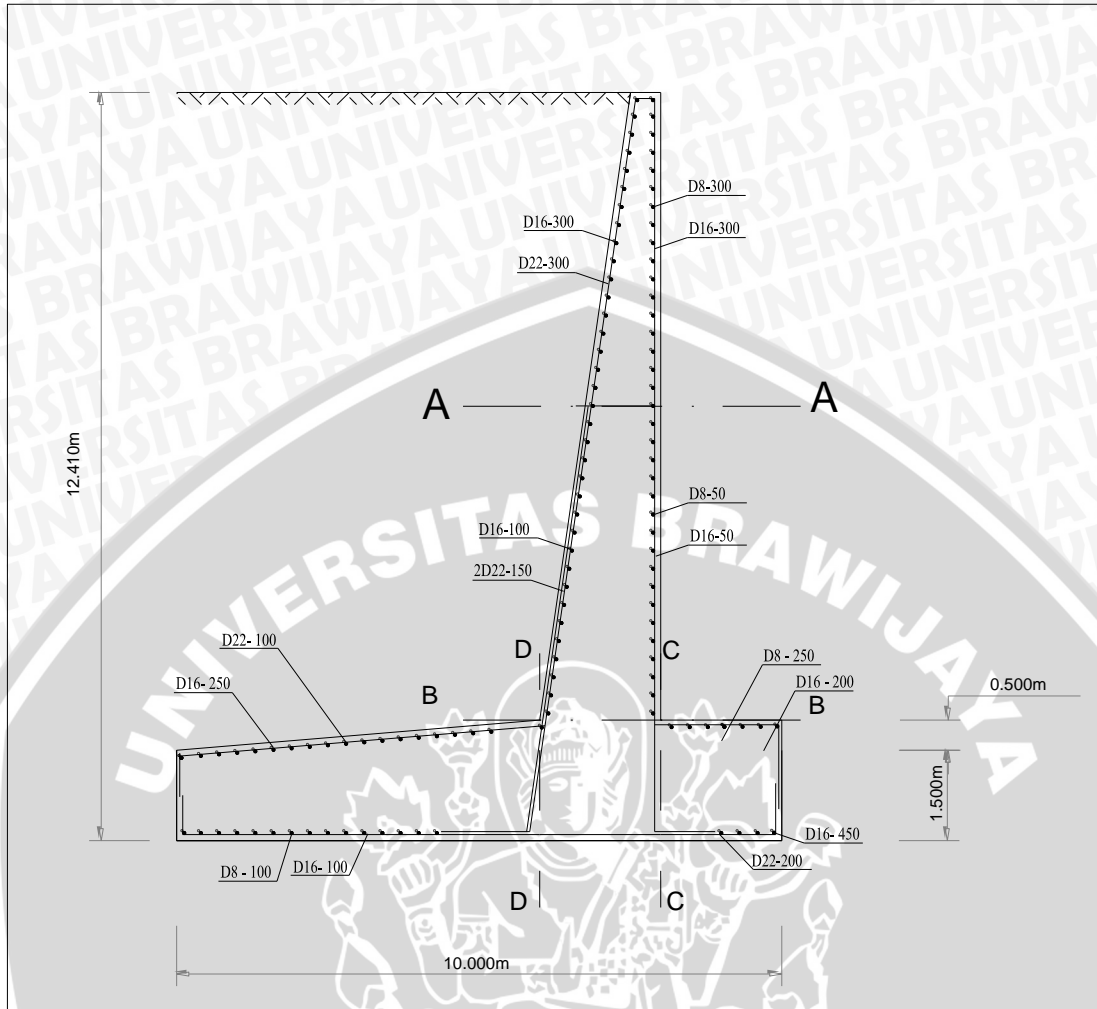

Gambar 4.84. Penulangan Pada Dinding Penahan Bagian Hilir

Tabel 4.73. Rekapitulasi Tulangan Pada Dinding Penahan

Dinding Penahan Bagian Hulu																
Potongan	A-A			B-B			C-C			D-D						
<b>Tulangan Tarik</b>																
Tulangan Utama	D	22	-	200	2D	22	-	200	D	22	-	250	D	22	-	100
Tulangan Pembagi	D	16	-	450	D	16	-	150	D	16	-	450	D	16	-	300
<b>Tulangan Tekan</b>																
Tulangan Utama	D	16	-	300	D	16	-	50	D	16	-	150	D	16	-	125
Tulangan Pembagi	D	8	-	450	D	8	-	50	D	8	-	300	D	8	-	150
Dinding Penahan Bagian Jembatan																
Potongan	A-A			B-B			C-C			D-D						
<b>Tulangan Tarik</b>																
Tulangan Utama	D	22	-	200	2D	22	-	200	D	22	-	200	D	22	-	100
Tulangan Pembagi	D	16	-	450	D	16	-	150	D	16	-	450	D	16	-	300
<b>Tulangan Tekan</b>																
Tulangan Utama	D	16	-	450	D	16	-	50	D	16	-	250	D	16	-	100
Tulangan Pembagi	D	8	-	450	D	8	-	50	D	8	-	300	D	8	-	150
Dinding Penahan Bagian Hulu																
Potongan	A-A			B-B			C-C			D-D						
<b>Tulangan Tarik</b>																
Tulangan Utama	D	22	-	300	2D	22	-	150	D	22	-	200	D	22	-	100
Tulangan Pembagi	D	16	-	300	D	16	-	100	D	16	-	450	D	16	-	250
<b>Tulangan Tekan</b>																
Tulangan Utama	D	16	-	300	D	16	-	50	D	16	-	200	D	16	-	100
Tulangan Pembagi	D	8	-	300	D	8	-	50	D	8	-	250	D	8	-	100

Sumber: Hasil Perhitungan

#### 4.6. Sambungan Konstruksi (*Construction Joint*) dan Sambungan Kontraksi (*Contraction Joint*)

Sambungan konstruksi (*construction joint*) memiliki peranan penting dalam berbagai struktur beton karena tidak mungkin untuk pembuatan suatu bangunan besar bisa dilakukan dalam satu kali pekerjaan, sehingga diperlukan sambungan konstruksi. Pengecoran beton dilaksanakan setiap tinggi tertentu dengan batas setinggi-tingginya 1,5 m – 2,0 m, tergantung volume dari beton total. Ini dimaksudkan agar agregat kasar tidak memisah yang dapat memperlemah kekuatan beton. Sedangkan sambungan konstruksi arah longitudinal kira-kira sambungan berjarak antara 10-30 m.

Sambungan kontraksi (*contraction joint*), Sambungan ini dipakai untuk mencegah terjadinya retakan. Retak dapat diminimalkan dengan memberikan rongga untuk pergerakan pada struktur beton. Hal yang biasa dilakukan adalah dengan membagi dinding menjadi beberapa bagian yang dipisahkan dengan panjang yang cocok oleh sambungan yang memungkinkan terjadi pergerakan. Dalam hal ini, sambungan tersebut menggunakan water stop. Penggunaan water stop diharapkan dapat mencegah air bocor melalui celah pada sambungan kontraksi. Bahan dari water stop ini harus memenuhi beberapa syarat, yaitu: kedap air, tahan lama dan dapat mengikuti gerakan memanjang atau menyusutnya sambungan.

Sambungan konstruksi dan kontraksi pada bangunan dalam studi ini dapat dilihat pada Gambar 4.85 – Gambar 4.90.



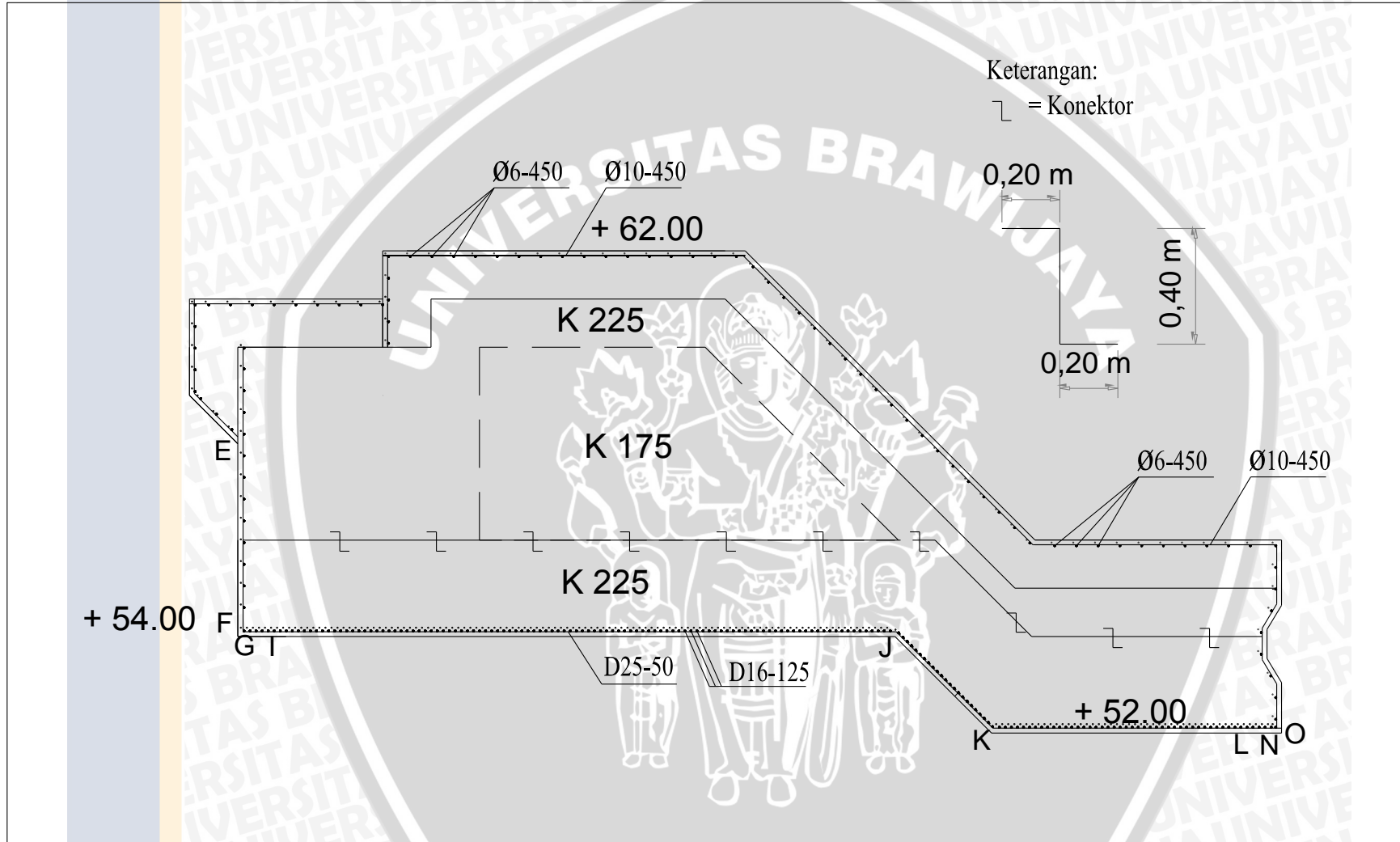

Gambar 4.85. Sambungan Konstruksi Pada Bendung Gerak

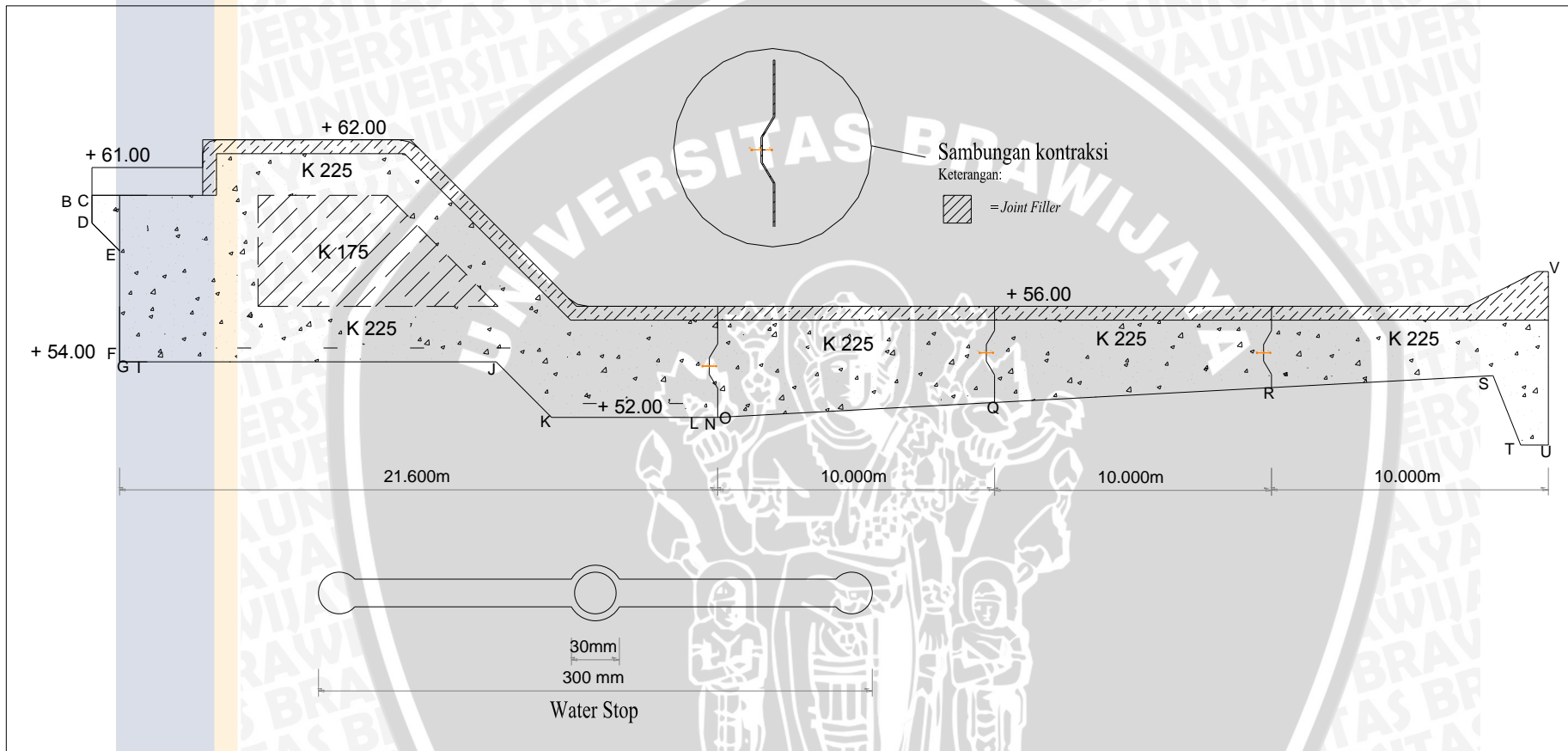

Gambar 4.86. Sambungan Kontraksi Pada Bendung Gerak

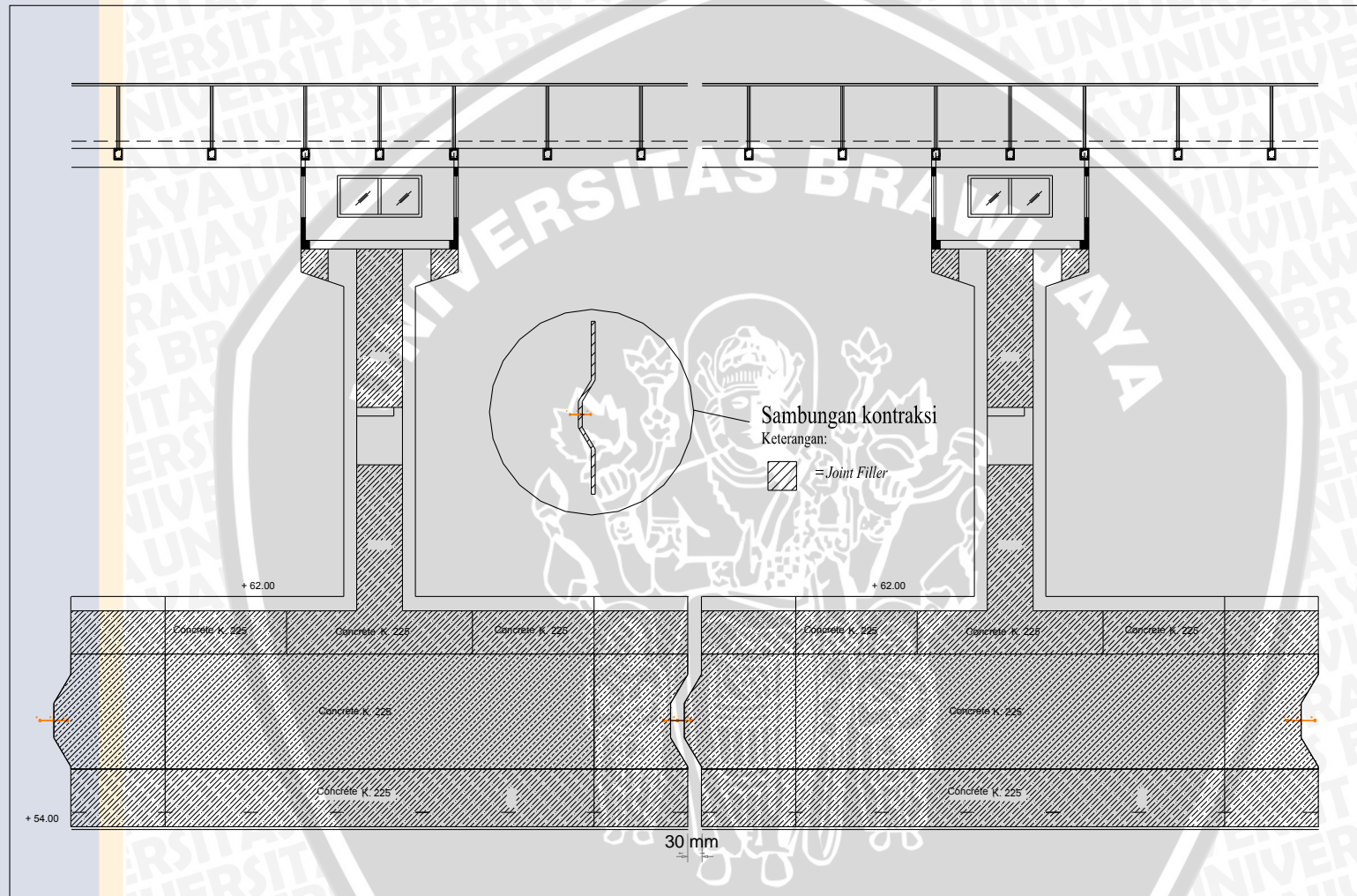

Gambar 4.87. Sambungan Kontraksi Pada Bendung Gerak

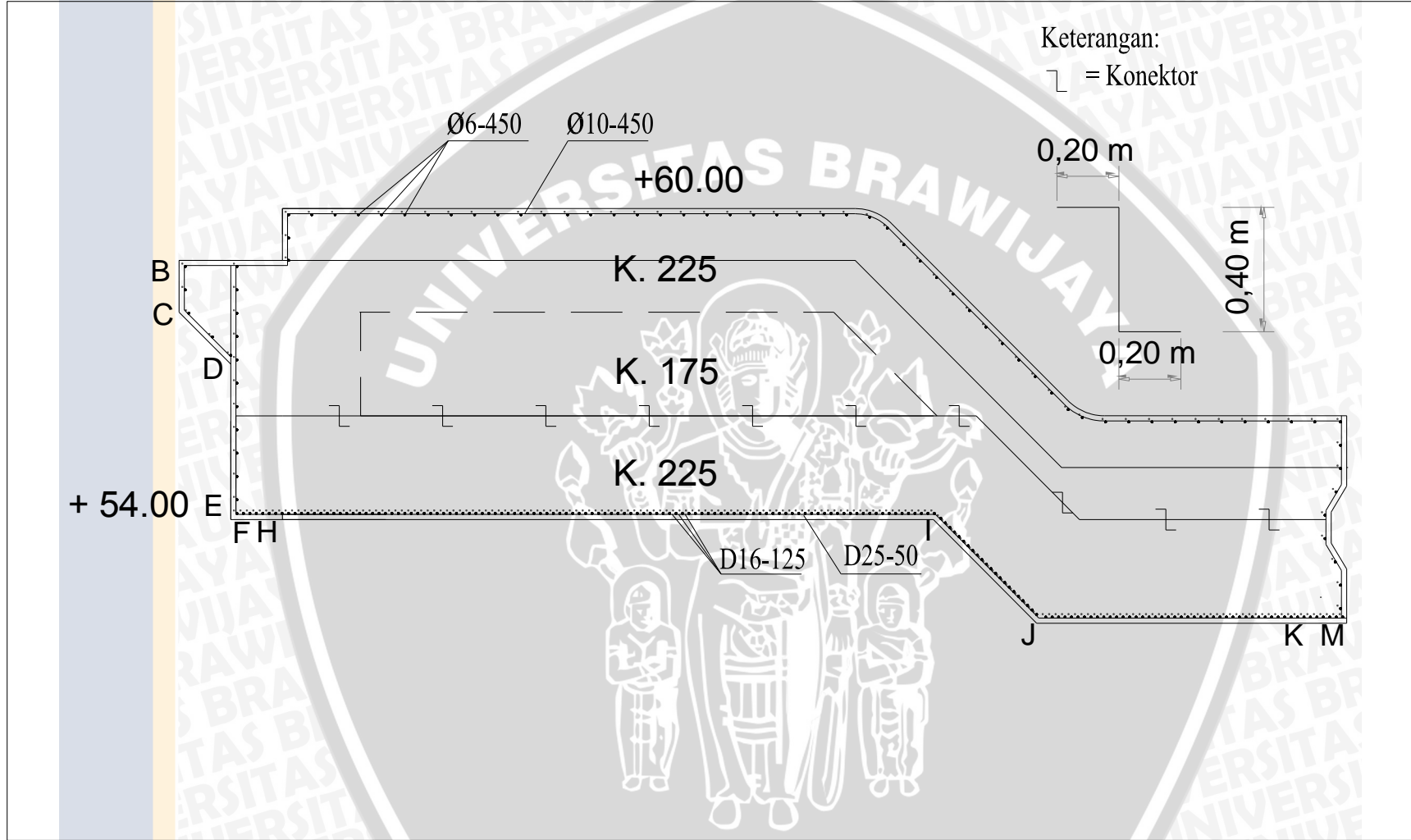

Gambar 4.88. Sambungan Konstruksi Pada Bangunan Penguras

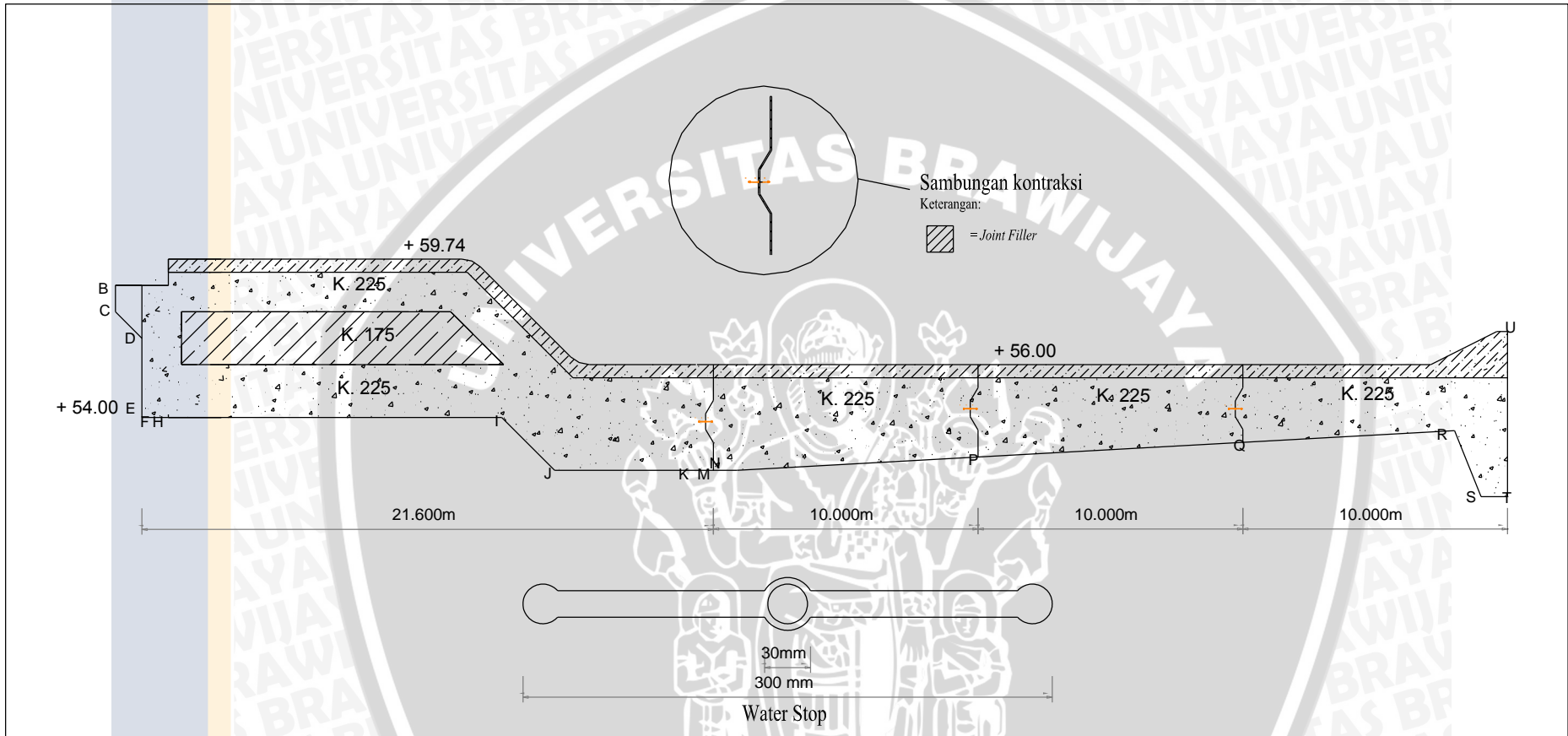

Gambar 4.89. Sambungan Kontraksi Pada Bangunan Penguras

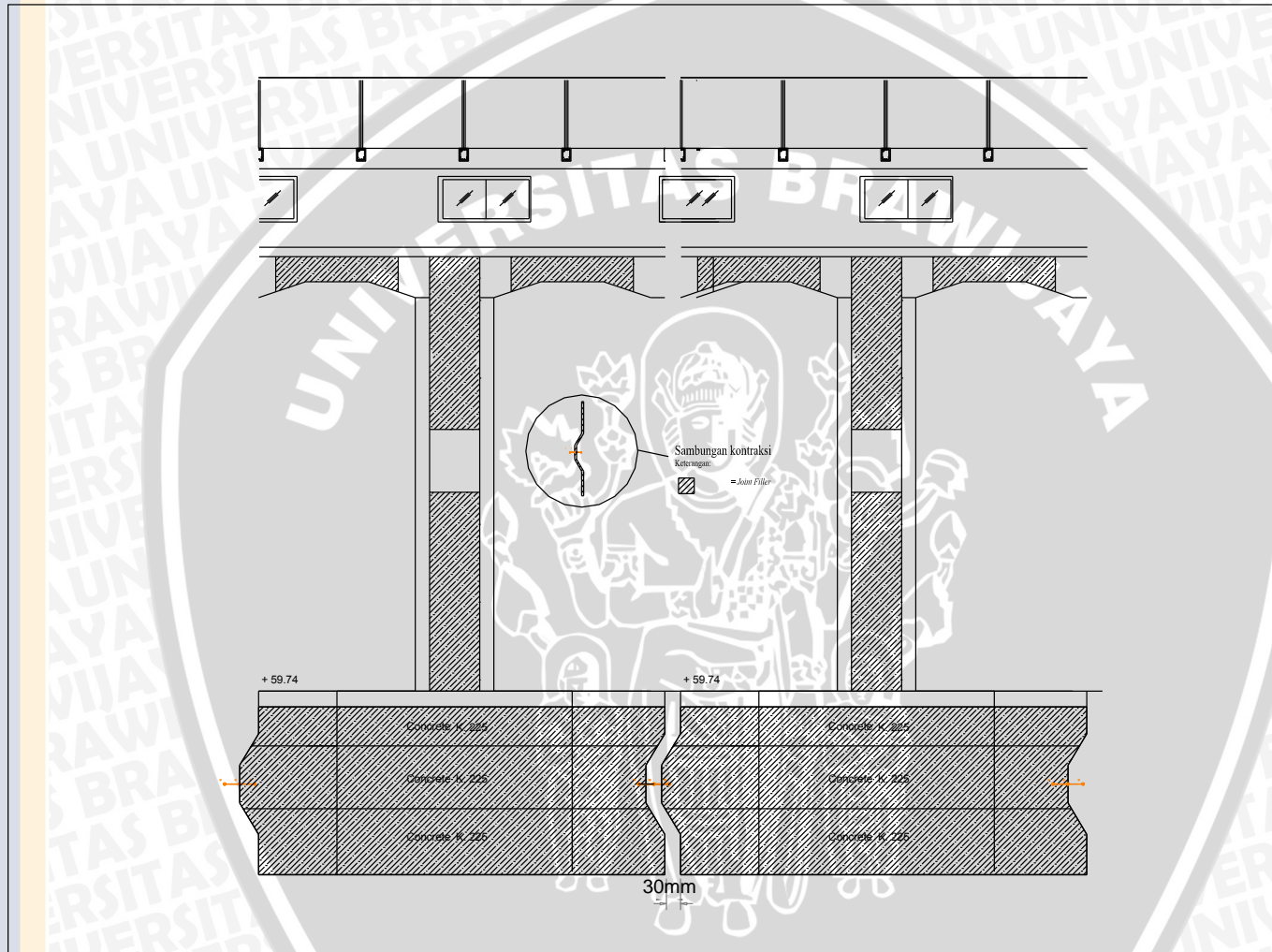

Gambar 4.90. Sambungan Kontraksi Pada Bangunan Penguras

