

## Lampiran 1. Komponen dan Alat yang Digunakan

### 1) Resistor 10kΩ 5W

Resistor 5w 10k

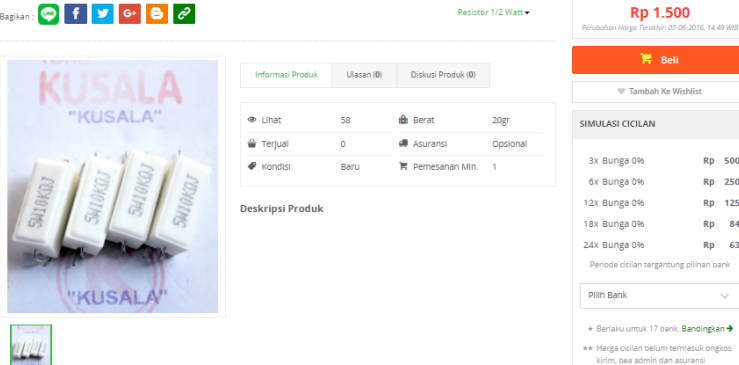

Resistor 1/2 Watt

Rp 1.500  
Perubahan Harga Terakhir: 05-06-2016, 14:49 WIB

Beli

Tambah Ke Wishlist

SIMULASI CICILAN	
3x Bunga 0%	Rp 500
6x Bunga 0%	Rp 250
12x Bunga 0%	Rp 125
18x Bunga 0%	Rp 84
24x Bunga 0%	Rp 63

Periode cicilan tergantung pilihan bank

Pilih Bank

+ Berlaku untuk 17 bank. [Bandingkan](#)

\*\* Harga cicilan belum termasuk ongkos kirim, bea admin dan asuransi

Informasi Produk | Ulasan (0) | Diskusi Produk (0)

Lihat: 58 | Berat: 20gr  
Terjual: 0 | Asuransi: Optional  
Kondisi: Baru | Pemesanan Min.: 1

Deskripsi Produk

### 2) Kapasitor 10 nF 3kV



AUDIOPARTS  
CERAMIC HV CAPACITOR

Kapasitor 10nf 103 3000v 3Kv High Voltage Hv Ceramic Film Capacitor

★★★★★ 2 ulasan

Rp1.200

Bisa Nego di App

Nikmati Cicilan 0% dengan belanja minimum Rp500.000 di lapak Audio Parts

GROSIR | Beli banyak lebih murah

Tersedia > 50 stok barang  
Masukkan jumlah yang diinginkan

- 5 +

Jumlah minimum pembelian barang adalah 5

Beli Sekarang

### 3) Resistor 1 MΩ 1W



Resistor Taiwan 1M 1 Watt

Rp500

Bisa Nego di App

Nikmati Cicilan 0% dengan belanja minimum Rp500.000 di lapak Wahoo Part

Tersedia > 1000 stok barang  
Masukkan jumlah yang diinginkan

- 10 +

Jumlah minimum pembelian barang adalah 10

Beli Sekarang

Tambahkan ke Keranjang

Chat Pelapak

- 4) Elektroda Tembaga Diameter 0,5mm



- 5) Baut Diameter 5mm



- 6) *Storage capacitor 25 $\mu$ F, 12kV*



- 7) Termometer Digital

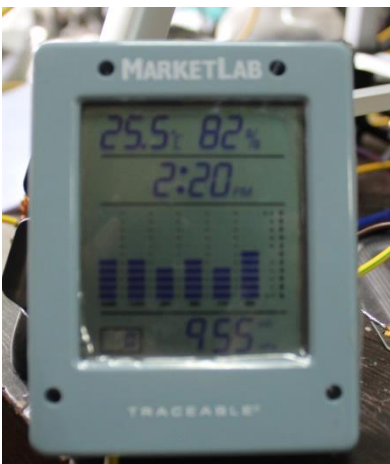

## 8) Osiloskop Hantek MSO5074FG



## 9) Mikrometer Sekrup Ketelitian 0,01mm



## 10) Probe Tegangan Tinggi



Lampiran 2. Dokumentasi Kegiatan

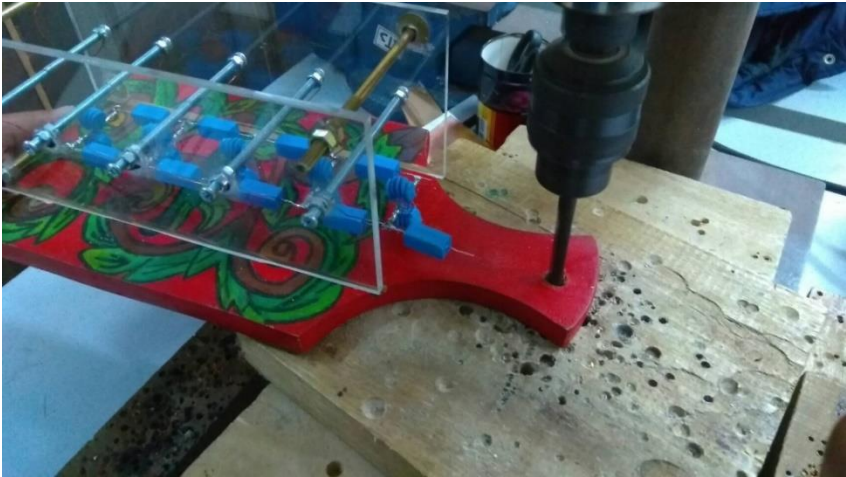

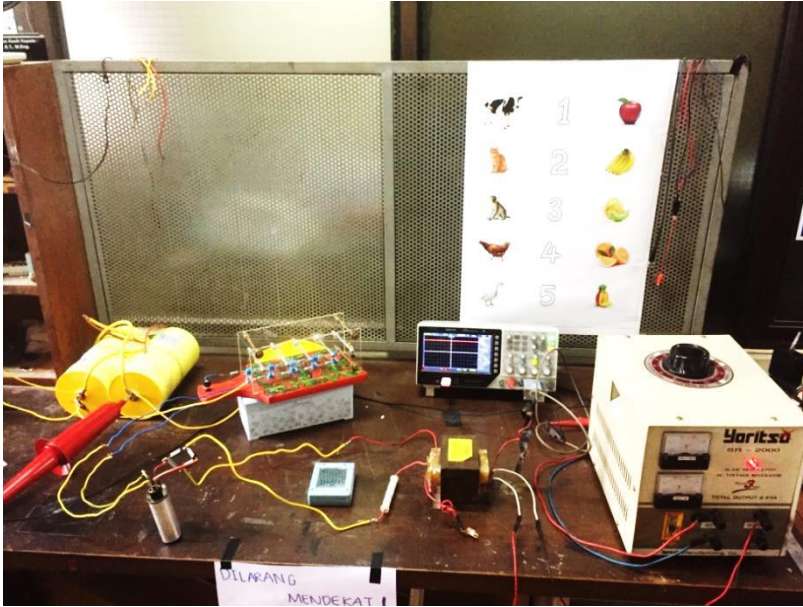

### Lampiran 3. Perhitungan *Charging Current Marx Generator*

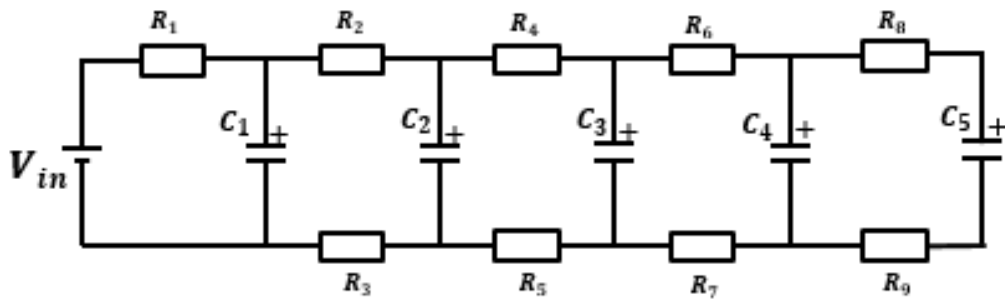

$$R_1 = R_2 = R_3 = R_4 = R_5 = R_6 = R_7 = R_8 = R_9 = 10 \text{ k}\Omega$$

$$C_1 = C_2 = C_3 = C_4 = C_5 = C = 1 \times 10^{-7} \text{ F}$$

$$\checkmark Z_1 = R_8 + R_9 + \frac{1}{C_5 s}$$

$$Z_1 = 2R + \frac{1}{Cs}$$

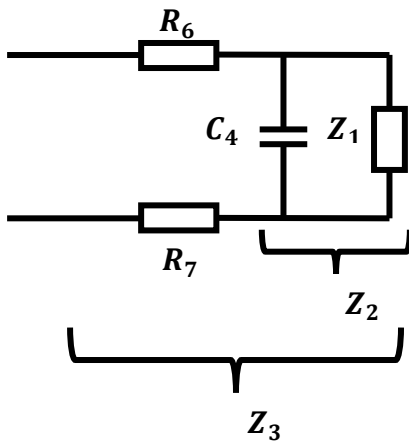

$$\checkmark Z_2 = C_4 // Z_1$$

$$\checkmark Z_3 = R_6 + R_7 + Z_2$$

$$\frac{1}{Z_2} = \frac{1}{Z_1} + C_4 s$$

$$= \frac{1}{2R + \frac{1}{Cs}} + Cs$$

$$Z_2 = \frac{2RCs + 1}{2RC^2s^2 + 2Cs}$$

$$= 2R + \frac{2RCs + 1}{2RC^2s^2 + 2Cs}$$

$$Z_3 = \frac{6RCs + 4R^2C^2s^2 + 1}{2Cs + 2RC^2s^2}$$

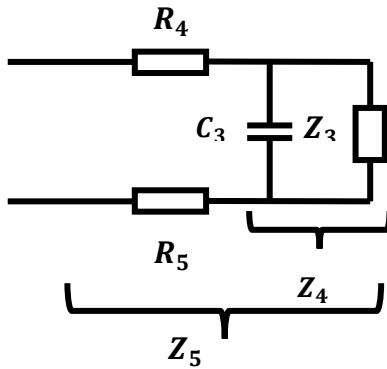

$$\checkmark \quad Z_4 = Z_3 // C_3$$

$$\frac{1}{Z_4} = \frac{1}{Z_3} + C_3 s$$

$$Z_4 = \frac{4R^2 C^2 s^2 + 6RCs + 1}{4R^2 C^3 s^3 + 3Cs + 8RC^2 s^2}$$

$$\checkmark \quad Z_5 = R_4 + R_5 + Z_4$$

$$= 2R + \frac{4R^2 C^2 s^2 + 6RCs + 1}{4R^2 C^3 s^3 + 3Cs + 8RC^2 s^2}$$

$$Z_5 = \frac{12RCs + 20R^2 C^2 s^2 + 8R^3 C^3 s^3 + 1}{3Cs + 8RC^2 s^2 + 4R^2 C^3 s^3}$$

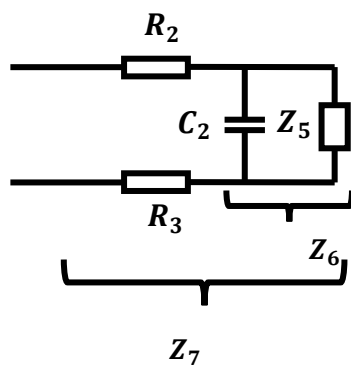

$$\checkmark \quad Z_6 = Z_5 // C_2$$

$$\frac{1}{Z_6} = \frac{1}{Z_5} + C_2 s$$

$$Z_6 = \frac{12RCs + 20R^2 C^2 s^2 + 8R^3 C^3 s^3 + 1}{3Cs + 8RC^2 s^2 + 4R^2 C^3 s^3}$$

$$\checkmark Z_7 = R_2 + R_3 + Z_6$$

$$Z_7 = \frac{s^4(16R^4C^4) + s^3(56R^3C^3) + s^2(60R^2C^2) + s(20RC) + 1}{s^4(8R^3C^4) + s^3(24R^2C^3) + s^2(20RC^2) + 4Cs}$$

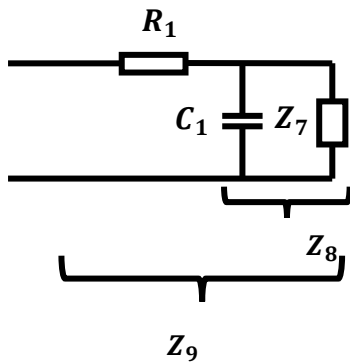

$$\checkmark Z_8 = Z_7 // C_1$$

$$\frac{1}{Z_8} = \frac{1}{Z_7} + C_1s$$

$$Z_8 = \frac{s^4(16R^4C^4) + s^3(56R^3C^3) + s^2(60R^2C^2) + s(20RC^2) + 1}{s^5(16R^4C^5) + s^4(64R^3C^4) + s^3(84R^2C^3) + s^2(40RC^2) + 5Cs}$$

$$\checkmark Z_9 = R_1 + Z_8$$

$$Z_9 = \frac{s^5(16R^5C^5) + s^4(80R^4C^4) + s^3(140R^3C^3) + s^2(100R^2C^2) + s(20RC^2 + 5RC) + 1}{s^5(16R^4C^5) + s^4(64R^3C^4) + s^3(84R^2C^3) + s^2(40RC^2) + 5Cs}$$

Substitusi nilai C dan R

Sehingga,

$$Z_9 = \frac{1,6x10^{-14}s^5 + 8x10^{-11}s^4 + 1,4x10^{-7}s^3 + 1x10^{-4}s^2 + 0,005s + 1}{1,6x10^{-18}s^5 + 6,4x10^{-15}s^4 + 8,4x10^{-12}s^3 + 4x10^{-9}s^2 + 5x10^{-7}s}$$

$$I(s) = \frac{V(s)}{Z(s)}, \text{ dimana } V(s) = 1500$$

$$I(s) = 1500 \times \frac{1,6x10^{-18}s^5 + 6,4x10^{-15}s^4 + 8,4x10^{-12}s^3 + 4x10^{-9}s^2 + 5x10^{-7}s}{1,6x10^{-14}s^5 + 8x10^{-11}s^4 + 1,4x10^{-7}s^3 + 1x10^{-4}s^2 + 0,005s + 1}$$



$$= \frac{2,4x10^{-15}s^5 + 9,6x10^{-12}s^4 + 1,26x10^{-8}s^3 + 6x10^{-6}s^2 + 7,5x10^{-4}s}{1,6x10^{-14}s^5 + 8x10^{-11}s^4 + 1,4x10^{-7}s^3 + 1x10^{-4}s^2 + 0,005s + 1}$$

Mencari akar-akar dari nilai penyebut  $I(s)$  menggunakan kalkulator *online*

roots  $1.4 \cdot 10^{-7}x^3 + 1 \cdot 10^{-4}x^2 + 0.005x + 1$  Go

Graph » Examples » Print Share

Solution Keep Practicing >

Roots of  $1.4 \cdot 10^{-7}x^3 + 1 \cdot 10^{-4}x^2 + 0.005x + 1$ :  $x = -\sqrt{210214908929}$

Steps

$1.4 \cdot 10^{-7}x^3 + 1 \cdot 10^{-4}x^2 + 0.005x + 1$

The roots are the intercepts with the x-axis ( $y = 0$ )

$1.4 \cdot 10^{-7}x^3 + 1 \cdot 10^{-4}x^2 + 0.005x + 1 = 0$

Expand  $1.4 \cdot 10^{-7}x^3 + 1 \cdot 10^{-4}x^2 + 0.005x + 1$ :  $0.00000014x^3 + 0.0001x^2 + 0.005x + 1$

$0.00000014x^3 + 0.0001x^2 + 0.005x + 1 = 0$

Find one solution for  $0.00000014x^3 + 0.0001x^2 + 0.005x + 1 = 0$  using Newton-Raphson:  
No Solution for  $x \in \mathbb{R}$

Newton-Raphson Approximation Definition  
The Newton-Raphson method uses an iterative process to approach one root of a function  
 $x_{n+1} = x_n - \frac{f(x_n)}{f'(x_n)}$

Find one solution for  $0.00000014x^3 + 0.0001x^2 + 0.005x + 1 = 0$  using Newton-Raphson:  
No Solution for  $x \in \mathbb{R}$

Newton-Raphson Approximation Definition  
The Newton-Raphson method uses an iterative process to approach one root of a function  
 $x_{n+1} = x_n - \frac{f(x_n)}{f'(x_n)}$

$f(x) = 0.00000014x^3 + 0.0001x^2 + 0.005x + 1$

Find  $f'(x)$ :  $0.00000042x^2 + 0.0002x + 0.005$

Let  $x_0 = -1$

Compute  $x_{n+1}$  until  $\Delta x_{n+1} < 0.000001$

$x_1 = -208.29433... : \Delta x_1 = 207.29433...$

$x_2 = -43.83938... : \Delta x_2 = 164.45495...$

$x_3 = 280.81440... : \Delta x_3 = 324.65378...$

$x_4 = 138.79557... : \Delta x_4 = 142.01883...$

$x_5 = 41.00558... : \Delta x_5 = 97.78999...$

$x_6 = -58.42592... : \Delta x_6 = 99.43150...$

$x_7 = 136.05410... : \Delta x_7 = 194.48002...$

$x_3 = 280.81440... : \Delta x_3 = 324.65378...$

$x_4 = 138.79557... : \Delta x_4 = 142.01883...$

$x_5 = 41.00558... : \Delta x_5 = 97.78999...$

$x_6 = -58.42592... : \Delta x_6 = 99.43150...$

$x_7 = 136.05410... : \Delta x_7 = 194.48002...$

$x_8 = 38.92029... : \Delta x_8 = 97.13381...$

$x_9 = -61.99677... : \Delta x_9 = 100.91706...$

Cannot find solution

$x \approx -677.12037...$

Approximate to algebraic form

$x \approx -677.12037... : x = -\sqrt{210214908929}$

$x = -\sqrt{210214908929}$

The final solution to the equation is:

$x = -\sqrt{210214908929}$

[click here to practice equations >](#)

$$\text{Laplace}(I(s)) = \frac{2,4x10^{-15}s^5 + 9,6x10^{-12}s^4 + 1,26x10^{-8}s^3 + 6x10^{-6}s^2 + 7,5x10^{-4}s}{(s + 677,12037)}$$

$$A = \frac{2,4x10^{-15}s^5 + 9,6x10^{-12}s^4 + 1,26x10^{-8}s^3 + 6x10^{-6}s^2 + 7,5x10^{-4}s}{(s + 677,12037)}; s = -677,12037$$

$$A = 0,007833$$

Maka ;

$$I(t) = \frac{0,007833}{s + 677,12037}$$

$$= 0,007833e^{-677,12037t}$$

Setelah melakukan plot nilai t pada Matlab dan Microsoft Excel, diperoleh nilai

$I(t)$  maksimum pada saat  $\frac{di(t)}{dt} = 0$ , yaitu:

```
r=10000;
c=0.0000001;
```

```
A=(16*r^5*c^5)
B=(80*r^4*c^4)
C=(140*r^3*c^3)
D=(100*r^2*c^2)
E=(20*r*c^2)+(5*r*c)
F=1
G=(16*r^4*c^5)
H=(64*r^3*c^4)
I=(84*r^2*c^3)
J=(40*r*c^2)
K=(5*c)
```

```
x1=-677.12037;
```

```
X=1500*((G*x1^5)+(H*x1^4)+(I*x1^3)+(J*x1^2)+(K*x1))
```

```
t=0.001:0.001:0.1;
```

```
it=(X*exp(-677.12037*t))
```

```
plot(t,it)
```

*Listing* program mencari  
nilai  $I(t)$  maksimum saat  
 $\frac{di(t)}{dt} = 0$  pada Matlab

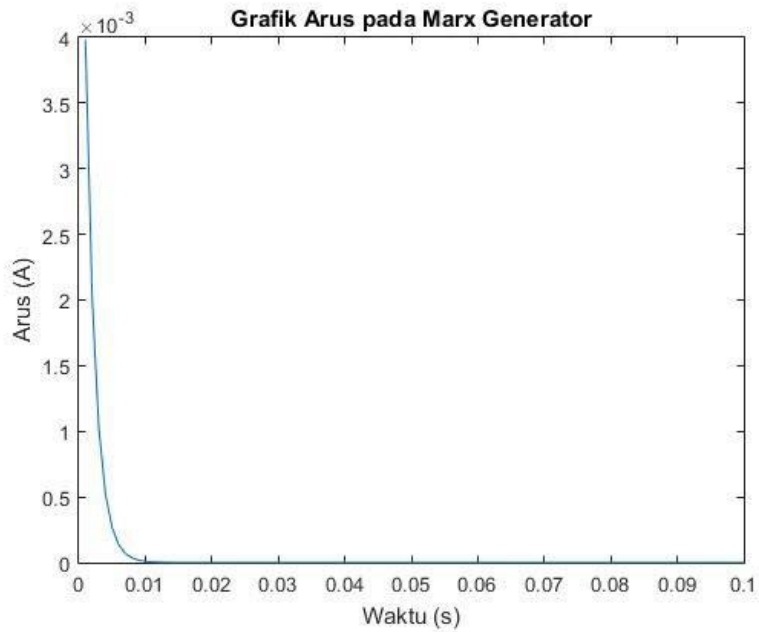

Plot nilai  $I(t)$  pada Microsoft Excel:

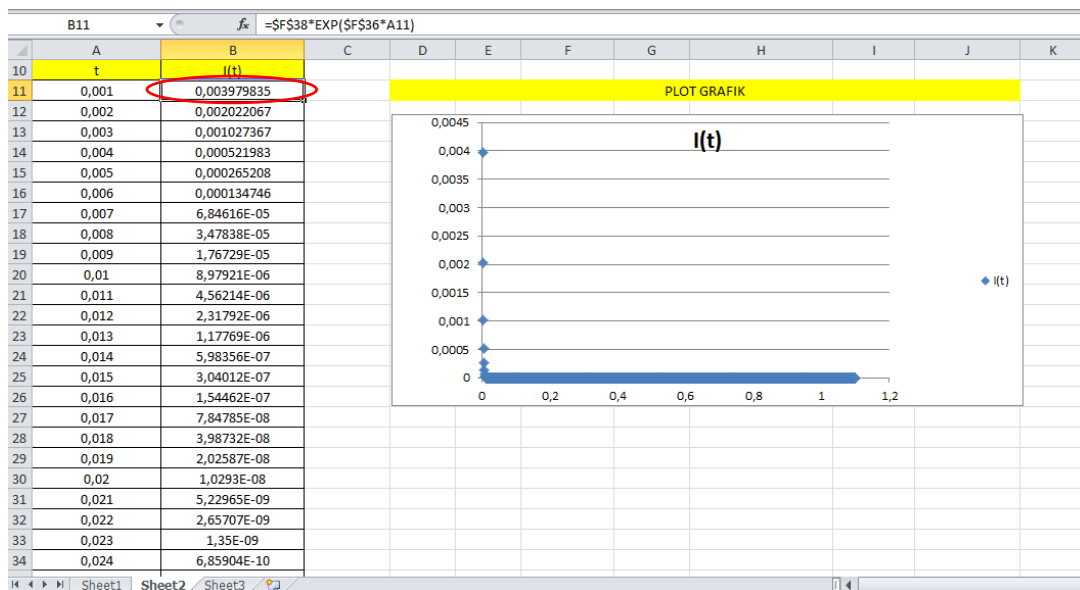

Berdasarkan perhitungan dan grafik tersebut nilai  $I(t)_{maks} = 0.003979835 \text{ Ampere}$

Maka, daya maksimum yang diserap  $R_1$  adalah:

$$\begin{aligned}
 P_{maks} &= I^2 \times R_1 \\
 &= (0,003979835)^2 \times 10.000 \\
 &= \mathbf{0,15839 \text{ Watt}}
 \end{aligned}$$